

2020 PRODUCT CATALOGUE



TECHNOLOGY INSIDE

Estep



*Quality
Innovation
Passion*

ESTAP COMPANY PROFILE

Estap is a major player in the Turkish electronics enclosures industry since 1989. ESTAP A.Ş. specializes in enclosures for data communication equipment, utilising basic 19" racks, cabinets and accessories, to provide solutions for networking, servers, data centers, outdoor applications, industrial usage and telecommunication.

In 2008, Estap was acquired by the Legrand Group.

In 2015 Inform and Estap joined forces to provide a full offer for DataCom market.

Estap Head office is in İstanbul / Ümraniye and the plant is located in Gebze / Kocaeli with ISO 9001:2015 Quality Management Systems, ISO 14001:2015 Environmental Management System, ISO 27001:2013 Information Security Management System and ISO 45001:2018 Occupational Health and Safety Management System.

Utilises technological and flexible machinery to ensure a high manufacturing capacity and the highest standards of quality. Alongside the ERP/MRP system, a statistical control process is applied for overall quality management whilst meeting the high volume production needs.

Owns and operates state-of-the art computer-assisted machinery and equipment and this cutting-edge technology is incorporated at every stage of production from workstation to assembly line.

Uses highly skilled manpower, high technological CNC machines (punching, laser & bending etc.) robotic welding, automated electrostatic powder coating with surface treatment process. Basing on the Lean production and Kaizen manufacturing techniques during product manufacturing, continuous improvement works are being applied in every process.

Estap was the first brand to meet international standards with TSE approved products in Turkey.

Dedicated to providing its customers with cost effective quality products offering the logistics, flexibility, engineering standards to ensure optimum performance, guaranteed by continuous, long-term technical support and exporting products to more than 65 countries with 70% of the total production.

INDEX

19" FREE-STANDING RACK CABINETS

DCMax	2-23
ServerMax	24-39
CloudMax	40-63
UniversalLine	64-77
EvoLine	78-93
RelayRack	94-103

WALL-MOUNTED CABINETS

ProLine	104-117
EcoLine&EcoLinePlus	118-131
SohoLine	132-141
Soho SlimLine	142-145

OUTDOOR CABINETS

GuardLine	146-159
IP55 Outdoor	160-165
Mobese	166-169

ACCESSORIES

PDU	170-174
-----	---------

DCMax

Intro DCMax cabinets with aesthetic design for hot/cold corridor data center architecture.



GENERAL CHARACTERISTICS

- IP20 protection level for cooling performance
- 80% perforated front/rear doors for best air circulation
- Heavy duty structure, 1500kg load carrying capacity
- Wide range of cabinet sizes and accessories
- Dimensions: 42/45/47U 600 or 800x1000/1100/1200 mm
- Ready for cold / hot corridor containment
- Ample variety of accessories
- Maximum inner space for servers
- Professional cable management on top, bottom and inner of the cabinet
- Compatibility with all vendors' servers
- High technical performance; grounding continuity



Energy efficiency in a professional solution.

Reliable, flexible, scalable
and high performance are
in the same cabinet.

- Aesthetic and professional view
- Overhead cable trays separate electrical and data cables
- 2 and 3 section Co-Location cabinets
- By using cable rings, airflow is improved, installation time and cost is reduced. It creates space savings and flexibility inside the cabinet
- Passed Belcore Zone 4 earthquake test with 1000kg. load
- With special design of side frames, you can move the 19" mounting rails while equipments loaded
- Simply the raceway for cables are created by fixing cable rings on all profiles in front and rear part of the cabinets
- Easy movable 19" profiles, to front/rear



DCMax

SEISMIC TEST REPORT

Bellcore Seismic Test shows us, the cabinet is how durable against vibration and movement.

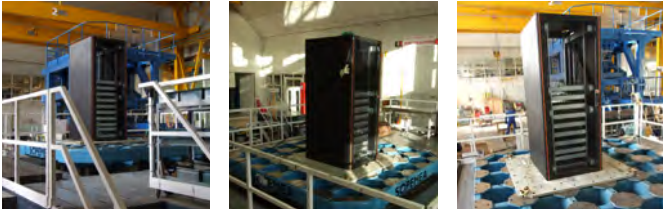

BELLCORE GR-63-CORE zone 4 (NEBS requirements) TEST HAS BEEN PASSED WITH 1000kg!

Resonance Frequency Test

Date	Axis	Program	Duration	Graph No	Comments
21/01/10	Z	A	6 min.	1 to 14	Nothing to report
21/01/10	X	A	6 min.	15 to 28	Nothing to report
21/01/10	Y	A	6 min.	29 to 42	Nothing to report

Earthquake Resistance Test

Date	Axis	Program	Duration	Graph No	Comments
22/01/10	Z	B	30 s	A 43 to 68	Nothing to report. No damage was observed on each tested part.
22/01/10	X	B	30 s	B 69 to 94	Nothing to report. No damage was observed on each tested part.
22/01/10	Y	B	30 s	C 95 to 120	Remark: during test, opening of the front mesh door and the rear mesh door. See video. Deformation of the front mesh door of the cabinet. Deformation of the rear mesh door closing linage. It is noted deformations inside the cabinet on recoveries of the 4 pillars. ESTAP informed SOPEMEA that door are not a relevant tested part (only for integration of cabinet for test process) Cracks on 2nd and 3rd rack. Deformation of vertical pillar on the 1st and 2nd rack. It's not broken, no cracks are detected. No deformation on the outer structure of the cabinet (out of mesh doors).

LOAD CARRYING CAPACITY TEST

1500kg Static Load to fix your equipments without any hesitation.



Diagonal Dimensions of ESTAP DCMAX Data Center Cabinet at Each Static Load

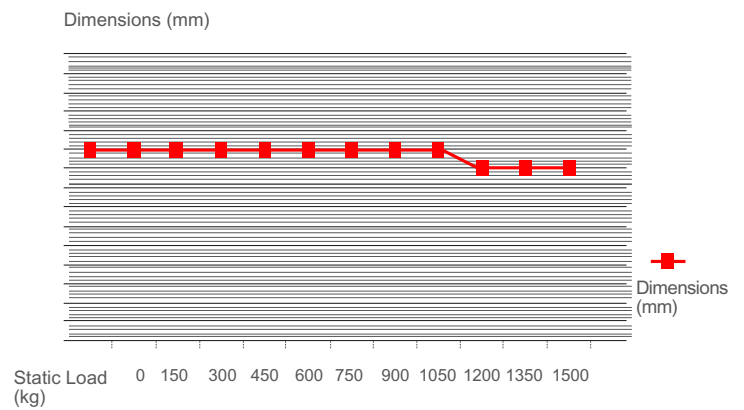

Thanks to the special structure and design, Estap DCMax cabinets can carry 1500kg static load.

DIMENSIONS

W: 600 MM CABINETS, SINGLE FRONT DOOR - DOUBLE REAR DOOR

Single opening curved 80% perforated front door; Double opening 80% perforated rear door.

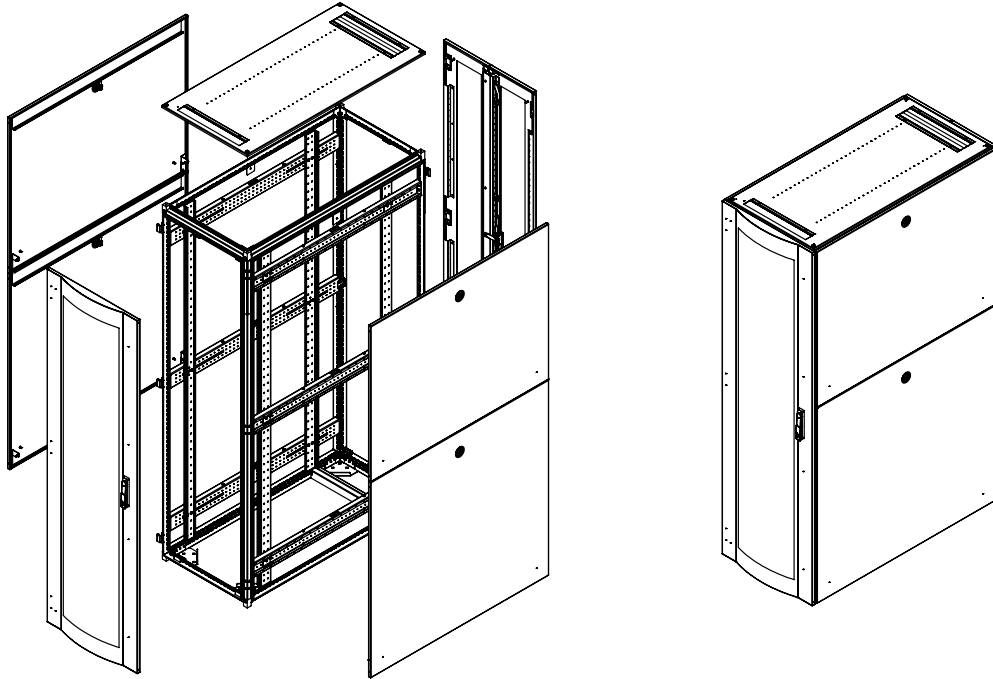

PRODUCT REFERENCE	DESCRIPTION	DIMENSIONS W x H x D (mm)
DC42U6010_M50_SVF80DVR80	19" 42U, 600x1000mm DcMAX, 80% Perforated, Single Opening Front and Double Opening Rear Doors	600x1990x1000
DC42U6011_M50_SVF80DVR80	19" 42U, 600x1100mm DcMAX, 80% Perforated, Single Opening Front and Double Opening Rear Doors	600x1990x1100
DC42U6012_M50_SVF80DVR80	19" 42U, 600x1200mm DcMAX, 80% Perforated, Single Opening Front and Double Opening Rear Doors	600x1990x1200
DC45U6010_M50_SVF80DVR80	19" 45U, 600x1000mm DcMAX, 80% Perforated, Single Opening Front and Double Opening Rear Doors	600x2140x1000
DC45U6011_M50_SVF80DVR80	19" 45U, 600x1100mm DcMAX, 80% Perforated, Single Opening Front and Double Opening Rear Doors.	600x2140x1100
DC45U6012_M50_SVF80DVR80	19" 45U, 600x1200mm DcMAX, 80% Perforated, Single Opening Front and Double Opening Rear Doors	600x2140x1200
DC47U6010_M50_SVF80DVR80	19" 47U, 600x1000mm DcMAX, 80% Perforated, Single Opening Front and Double Opening Rear Doors	600x2240x1000
DC47U6011_M50_SVF80DVR80	19" 47U, 600x1100mm DcMAX, 80% Perforated, Single Opening Front and Double Opening Rear Doors	600x2240x1100
DC47U6012_M50_SVF80DVR80	19" 47U, 600x1200mm DcMAX, 80% Perforated, Single Opening Front and Double Opening Rear Doors.	600x2240x1200

Note: Color code "M50" is RAL 9005 black, "M2" RAL 7035 light grey option is available.

DCMax

DIMENSIONS

W: 600 MM CABINETS, SINGLE FRONT DOOR - SINGLE REAR DOOR

Single opening curved 80% perforated front door; Single opening 80% perforated rear door.

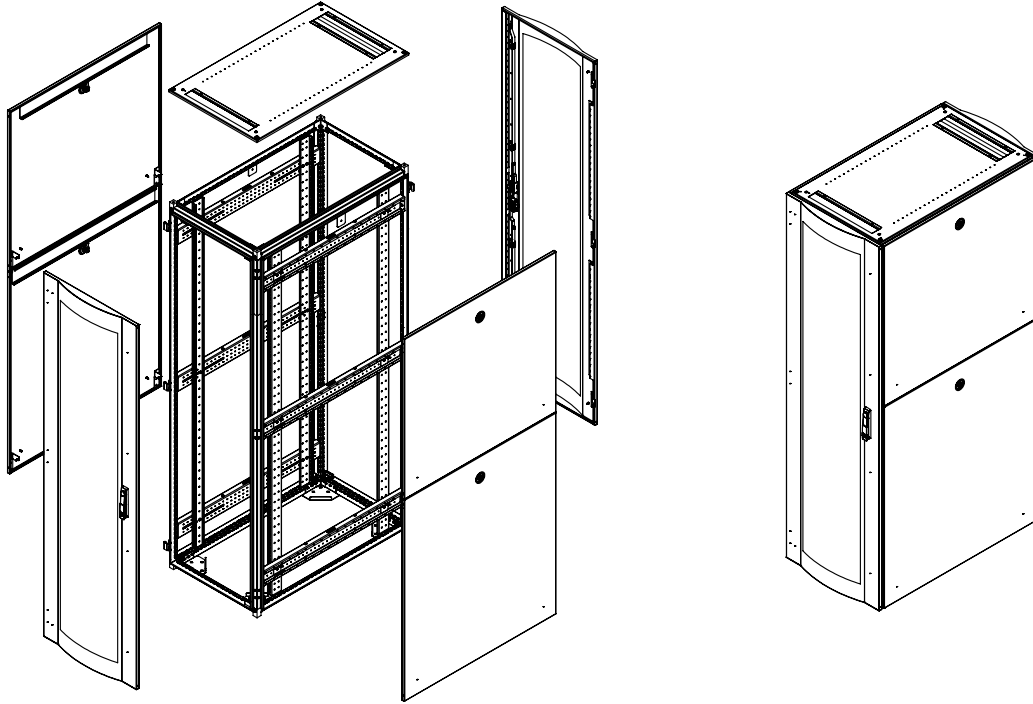

PRODUCT REFERENCE	DESCRIPTION	DIMENSIONS W x H x D (mm)
DC42U6010_M50_SVF80SVR80	19" 42U, 600x1000mm DcMAX, 80% Perforated, Single Opening Front and Rear Doors.	600x1990x1000
DC42U6011_M50_SVF80SVR80	19" 42U, 600x1100mm DcMAX, 80% Perforated, Single Opening Front and Rear Doors.	600x1990x1100
DC42U6012_M50_SVF80SVR80	19" 42U, 600x1200mm DcMAX, 80% Perforated, Single Opening Front and Rear Doors.	600x1990x1200
DC45U6010_M50_SVF80SVR80	19" 45U, 600x1000mm DcMAX, 80% Perforated, Single Opening Front and Rear Doors.	600x2140x1000
DC45U6011_M50_SVF80SVR80	19" 45U, 600x1100mm DcMAX, 80% Perforated, Single Opening Front and Rear Doors.	600x2140x1100
DC45U6012_M50_SVF80SVR80	19" 45U, 600x1200mm DcMAX, 80% Perforated, Single Opening Front and Rear Doors.	600x2140x1200
DC47U6010_M50_SVF80SVR80	19" 47U, 600x1000mm DcMAX, 80% Perforated, Single Opening Front and Rear Doors.	600x2240x1000
DC47U6011_M50_SVF80SVR80	19" 47U, 600x1100mm DcMAX, 80% Perforated, Single Opening Front and Rear Doors.	600x2240x1100
DC47U6012_M50_SVF80SVR80	19" 47U, 600x1200mm DcMAX, 80% Perforated, Single Opening Front and Rear Doors.	600x2240x1200

Note: Color code "M50" is RAL 9005 black, "M2" RAL 7035 light grey option is available.

DIMENSIONS

W: 800 MM CABINETS, SINGLE FRONT DOOR - DOUBLE REAR DOOR

Single opening curved 80% perforated front door; Double opening 80% perforated rear door.

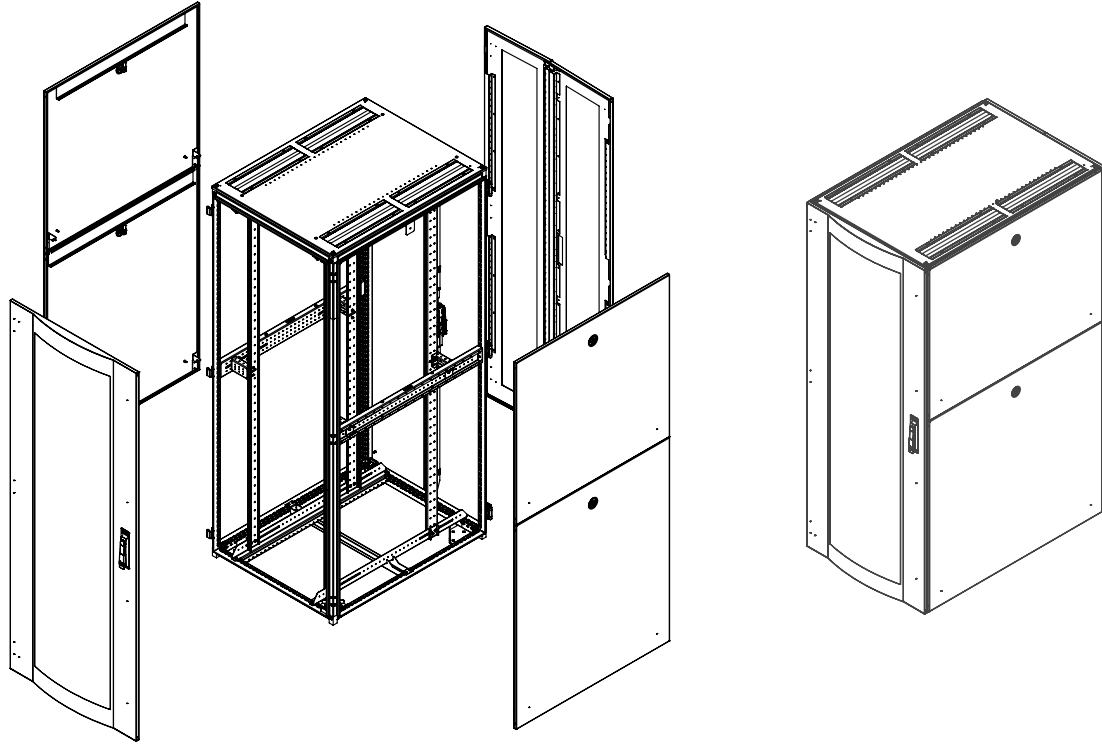

PRODUCT REFERENCE	DESCRIPTION	DIMENSIONS W x H x D (mm)
DC42U8010_M50_SVF80DVR80	19" 42U, 800x1000mm DcMAX, 80% Perforated, Single Opening Front and Double Opening Rear Doors	800x1990x1000
DC42U8011_M50_SVF80DVR80	19" 42U, 800x1100mm DcMAX, 80% Perforated, Single Opening Front and Double Opening Rear Doors	800x1990x1100
DC42U8012_M50_SVF80DVR80	19" 42U, 800x1200mm DcMAX, 80% Perforated, Single Opening Front and Double Opening Rear Doors	800x1990x1200
DC45U8010_M50_SVF80DVR80	19" 45U, 800x1000mm DcMAX, 80% Perforated, Single Opening Front and Double Opening Rear Doors	800x2140x1000
DC45U8011_M50_SVF80DVR80	19" 45U, 800x1100mm DcMAX, 80% Perforated, Single Opening Front and Double Opening Rear Doors	800x2140x1100
DC45U8012_M50_SVF80DVR80	19" 45U, 800x1200mm DcMAX, 80% Perforated, Single Opening Front and Double Opening Rear Doors	800x2140x1200
DC47U8010_M50_SVF80DVR80	19" 47U, 800x1000mm DcMAX, 80% Perforated, Single Opening Front and Double Opening Rear Doors	800x2240x1000
DC47U8011_M50_SVF80DVR80	19" 47U, 800x1100mm DcMAX, 80% Perforated, Single Opening Front and Double Opening Rear Doors	800x2240x1100
DC47U8012_M50_SVF80DVR80	19" 47U, 800x1200mm DcMAX, 80% Perforated, Single Opening Front and Double Opening Rear Doors	800x2240x1200

Note: Color code "M50" is RAL 9005 black, "M2" RAL 7035 light grey option is available.

DCMax

DIMENSIONS

W: 800 MM CABINETS, SINGLE FRONT DOOR - SINGLE REAR DOOR

Single opening curved 80% perforated front door; Single opening 80% perforated rear door.

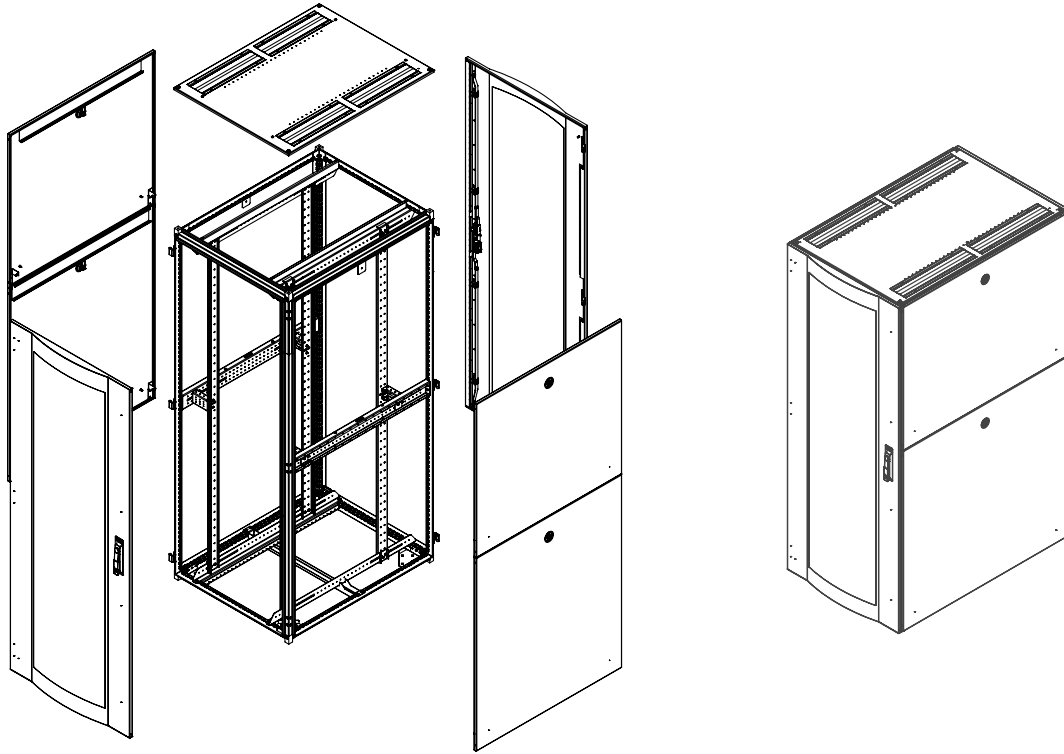

PRODUCT REFERENCE	DESCRIPTION	DIMENSIONS W x H x D (mm)
DC42U8010_M50_SVF80SVR80	19" 42U, 800x1000mm DcMAX, 80% Perforated, Single Opening Front and Rear Doors.	800x1990x1000
DC42U8011_M50_SVF80SVR80	19" 42U, 800x1100mm DcMAX, 80% Perforated, Single Opening Front and Rear Doors.	800x1990x1100
DC42U8012_M50_SVF80SVR80	19" 42U, 800x1200mm DcMAX, 80% Perforated, Single Opening Front and Rear Doors.	800x1990x1200
DC45U8010_M50_SVF80SVR80	19" 45U, 800x1000mm DcMAX, 80% Perforated, Single Opening Front and Rear Doors.	800x2140x1000
DC45U8011_M50_SVF80SVR80	19" 45U, 800x1100mm DcMAX, 80% Perforated, Single Opening Front and Rear Doors.	800x2140x1100
DC45U8012_M50_SVF80SVR80	19" 45U, 800x1200mm DcMAX, 80% Perforated, Single Opening Front and Rear Doors.	800x2140x1200
DC47U8010_M50_SVF80SVR80	19" 47U, 800x1000mm DcMAX, 80% Perforated, Single Opening Front and Rear Doors.	800x2240x1000
DC47U8011_M50_SVF80SVR80	19" 47U, 800x1100mm DcMAX, 80% Perforated, Single Opening Front and Rear Doors.	800x2240x1100
DC47U8012_M50_SVF80SVR80	19" 47U, 800x1200mm DcMAX, 80% Perforated, Single Opening Front and Rear Doors.	800x2240x1200

Note: Color code "M50" is RAL 9005 black, "M2" RAL 7035 light grey option is available.

TECHNICAL DRAWINGS (mm)

TOP VIEWS

Bellcore Seismic Test shows us, the cabinet is how durable against vibration and movement.

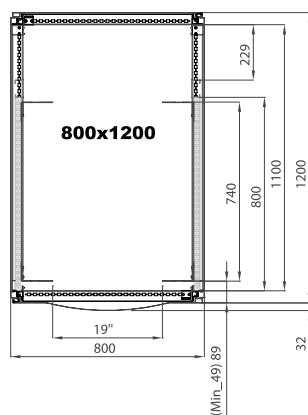
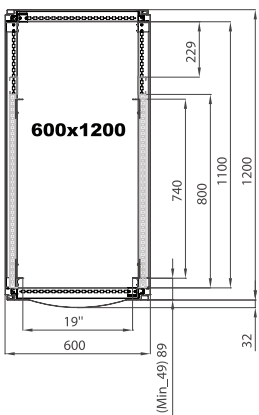
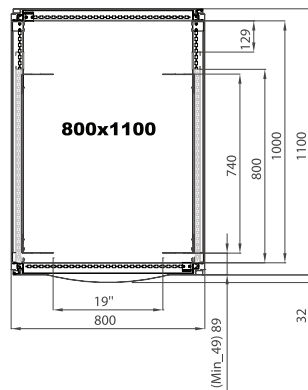
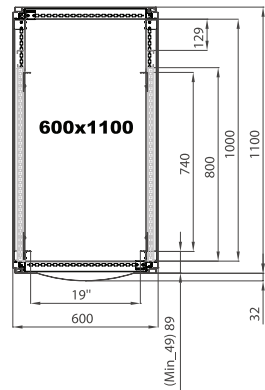
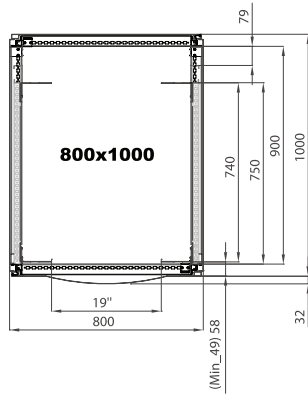
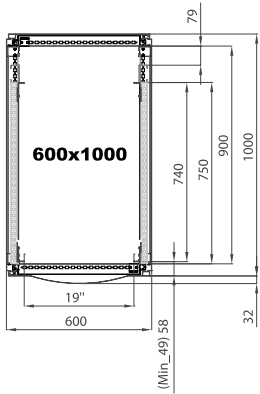

ROOF OPTIONS

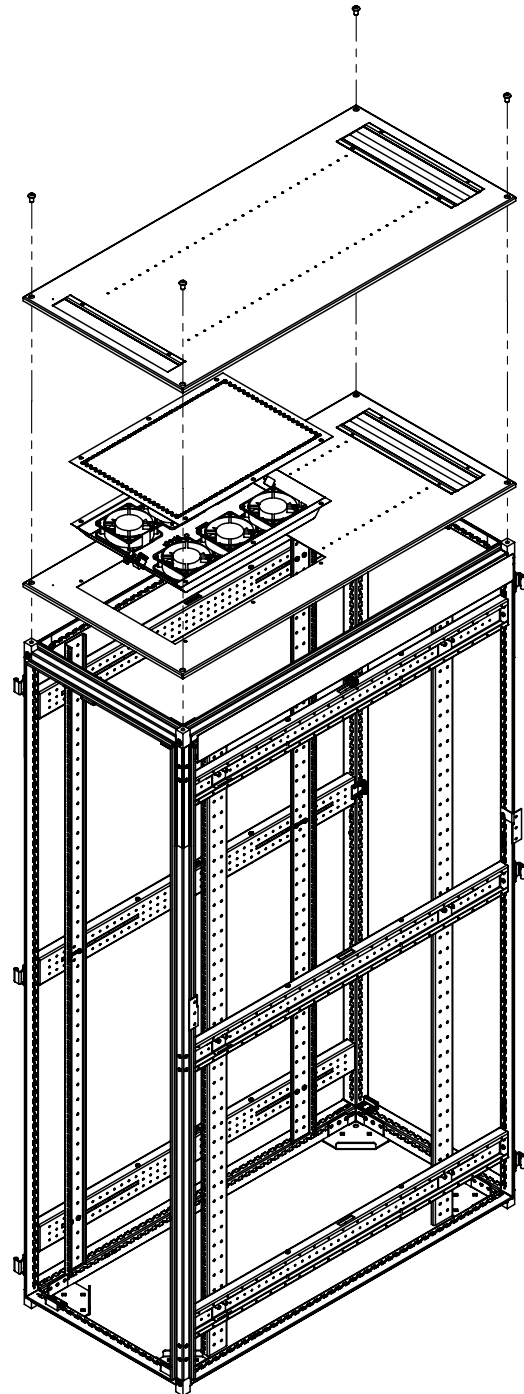

BRUSHED TYPE CABLE ENTRY

Maximum cable capacity with multiple cable entries. The dimensions of the cable entries are different according to the depth of the cabinet.

For 1000 mm depth: 90 mm x 300 mm (x4)

For 1100 mm depth: 90 mm x 350 mm (x4)

For 1200 mm depth: 90 mm x 400 mm (x4)

At the rear; 95 mm x 400 mm

FAN MODULE

4 or 6 pcs. of fan on a module, with ON/OFF, analog or digital thermostat functions. Complete inner wiring. 1U.

CASTER AND LEVELLING FEET

Rotational type casters, 2 pieces front have lockable function
Levelling feet: Height adjustment from the floor 250 kg. load carrying capacity of each wheel and each levelling feet.

LED LIGHT

Effective and powerful lighting.

Different dimensions 19", 1U, with ON/OFF switch, automatic door with ON/OFF switch or LED with sensor.

GROUNDING CONTINUITY

Grounding cables for all metal components. Cable connections with bolts and nuts for all doors.

RAISED FLOOR SUPPORT KIT

Fixing the cabinet to floor (under raised floor) for better stability, adjustable depth= 400-700 mm. suitable for w=600 mm and 800 mm.

DCMax Accessories

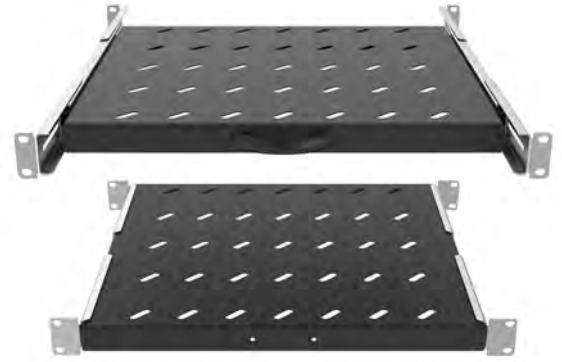

CABLE TRAY

Options from 42U to 47U, w=100 mm and 200 mm. The galvanized coating must be perforated to provide length and cable installation along the height of the cabinet. Unified cable tray for every cabinet range.

FIXED AND SLIDING SHELF

Fixing points at the sides of rear and front 19" uprights. Vented for air circulation, adjustable depth, sheet steel material.

BRUSHED TYPE CABLE ENTRY

There are 4 pieces according to the depth of the cabinet.
 For 1000 mm depth: 90 mm x 400 mm (x4)
 For 1100 mm depth: 90 mm x 450 mm (x4)
 For 1200 mm depth: 90 mm x 500 mm (x4)

AIR FLOW PREVENTATIVE ORGANIZER

Options from 42U to 47U. Professional cabling with finger type structure makes the user's work easier. Prevents the mixing of hot and cold air with its air flow preventive panels and ensures the system to work more healthy.



The image is for the width of 800 mm cabinet

DCMax IP 55 Cabinets



Structure: Produced from DKP sheet metal

Main body support closed form profile structure: 1,5 mm

Front and rear door: 2 mm

Top cover: 1,5 mm

Bottom panel: 2 mm

Side panels: 1,5 mm

Cable entry panel: 1,2 mm

Depth and modular mounting profile: 1,5 mm

19" device mounting uprights: 1,5 mm

Tempered glass: 4 mm

Surface finish: Cabinet profiles, doors, covers and panels are electrostatic powder coating.

Color: RAL 7035 light grey or RAL 9005 black

Mounting profile, cable entry, 19" device mounting profiles, C-profiles are made of galvanized material.

IP Protection:

IP55 according to EN 60529

IP55 protection with cast gasket.

Shipment configuration:

Main body structure, steel (1 pcs.)

Front door (1 pcs.) tempered glass, cast gasket inside metal frame

Rear door, cast gasket (1 pcs.)

Side panels, cast gasket (2 pcs.)

Top cover panel, cast gasket (1 pcs.)

Cable entry panels (3 pcs.= 1 set)

Door hinges (6 set)

The complementary lock can be from 3 point locking mechanism for the front and rear doors (2 set)

Grounding cables (for all the panels)

Fixings (1 set)

Plinth (1 set)

19» device mounting profiles (4 pcs.)

PRODUCT REFERENCE	DESCRIPTION	DIMENSIONS W x H x D (mm)
DC24U6060_M50_IP55	24U, 600x600mm, IP55, full glass frame front door, single front and rear doors	600x1200x600
DC32U6060_M50_IP55	32U, 600x600mm, IP55, full glass frame front door, single front and rear doors	600x1600x600
DC36U6060_M50_IP55	36U, 600x600mm, IP55, full glass frame front door, single front and rear doors	600x1800x600
DC42U6060_M50_IP55	42U, 600x600mm, IP55, full glass frame front door, single front and rear doors	600x2000x600
DC47U6060_M50_IP55	47U, 600x600mm, IP55, full glass frame front door, single front and rear doors	600x2200x600
DC24U6080_M50_IP55	24U, 600x800mm, IP55, full glass frame front door, single front and rear doors	600x1200x800
DC32U6080_M50_IP55	32U, 600x800mm, IP55, full glass frame front door, single front and rear doors	600x1600x800
DC36U6080_M50_IP55	36U, 600x800mm, IP55, full glass frame front door, single front and rear doors	600x1800x800
DC42U6080_M50_IP55	42U, 600x800mm, IP55, full glass frame front door, single front and rear doors	600x2000x800
DC47U6080_M50_IP55	47U, 600x800mm, IP55, full glass frame front door, single front and rear doors	600x2200x800
DC24U6010_M50_IP55	24U, 600x1000mm, IP55, full glass frame front door, single front and rear doors	600x1200x1000
DC32U6010_M50_IP55	32U, 600x1000mm, IP55, full glass frame front door, single front and rear doors	600x1600x1000
DC36U6010_M50_IP55	36U, 600x1000mm, IP55, full glass frame front door, single front and rear doors	600x1800x1000
DC42U6010_M50_IP55	42U, 600x1000mm, IP55, full glass frame front door, single front and rear doors	600x2000x1000
DC47U6010_M50_IP55	47U, 600x1000mm, IP55, full glass frame front door, single front and rear doors	600x2200x1000
DC24U8080_M50_IP55	24U, 800x800mm, IP55, full glass frame front door, single front and rear doors	800x1200x800
DC32U8080_M50_IP55	32U, 800x800mm, IP55, full glass frame front door, single front and rear doors	800x1600x800
DC36U8080_M50_IP55	36U, 800x800mm, IP55, full glass frame front door, single front and rear doors	800x1800x800
DC42U8080_M50_IP55	42U, 800x800mm, IP55, full glass frame front door, single front and rear doors	800x2000x800
DC47U8080_M50_IP55	47U, 800x800mm, IP55, full glass frame front door, single front and rear doors	800x2200x800
DC24U8010_M50_IP55	24U, 800x1000mm, IP55, full glass frame front door, single front and rear doors	800x1200x1000
DC32U8010_M50_IP55	32U, 800x1000mm, IP55, full glass frame front door, single front and rear doors	800x1600x1000
DC36U8010_M50_IP55	36U, 800x1000mm, IP55, full glass frame front door, single front and rear doors	800x1800x1000
DC42U8010_M50_IP55	42U, 800x1000mm, IP55, full glass frame front door, single front and rear doors	800x2000x1000
DC47U8010_M50_IP55	47U, 800x1000mm, IP55, full glass frame front door, single front and rear doors	800x2200x1000

Note: Color code "M50" is RAL 9005 black, "M2" RAL 7035 light grey option is available.

DCMax Co-Location Cabinets

Sometimes your equipments not fill much more than 10U or 20U. In this case you need Co-Location cabinets.

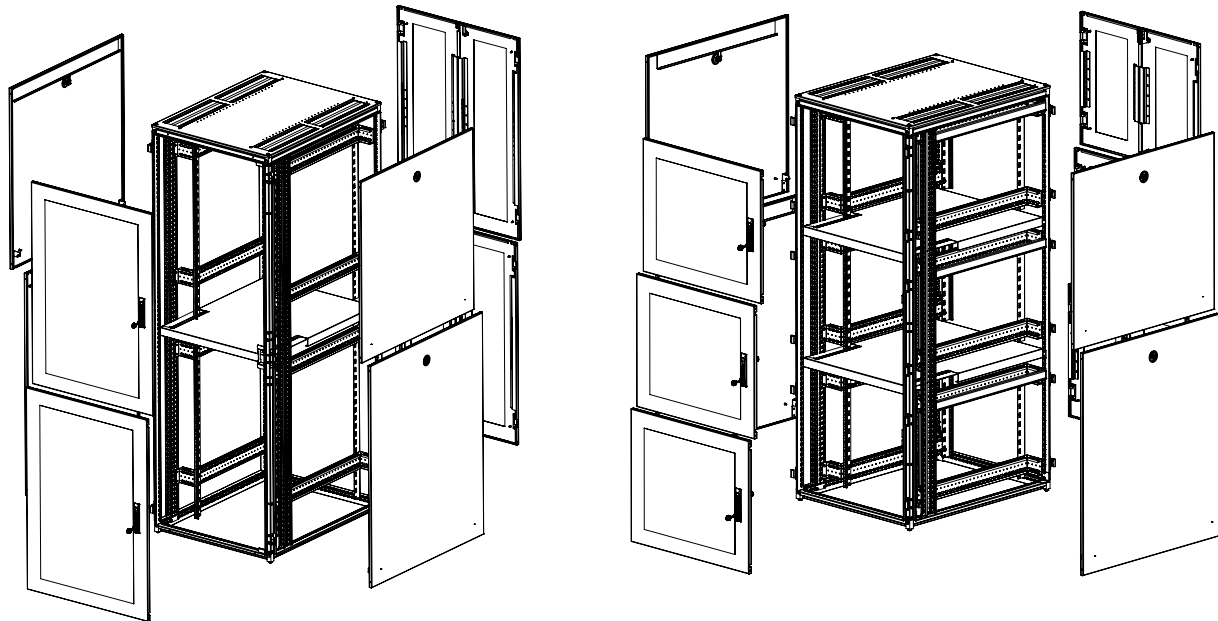

PRODUCT REFERENCE	DESCRIPTION	DIMENSIONS W x H x D (mm)
DC42U8010_M50_SVF80DVR80C2	42U 800X1000 mm, IP20, 80% perforated, single opening front and double opening rear doors, mechanical lock, black, co-location, 2 compartment	800x2000x1000
DC42U8011_M50_SVF80DVR80C2	42U 800X1100 mm, IP20, 80% perforated, single opening front and double opening rear doors, mechanical lock, black, co-location, 2 compartment	800x2000x1100
DC42U8012_M50_SVF80DVR80C2	42U 800X1200 mm, IP20, 80% perforated, single opening front and double opening rear doors, mechanical lock, black, co-location, 2 compartment	800x2000x1200
DC42U8010_M50_SVF80DVR80C3	42U 800X1000 mm, IP20, 80% perforated, single opening front and double opening rear doors, mechanical lock, black, co-location, 3 compartment	800x2000x1000
DC42U8011_M50_SVF80DVR80C3	42U 800X1100 mm, IP20, 80% perforated, single opening front and double opening rear doors, mechanical lock, black, co-location, 3 compartment	800x2000x1100
DC42U8012_M50_SVF80DVR80C3	42U 800X1200 mm, IP20, 80% perforated, single opening front and double opening rear doors, mechanical lock, black, co-location, 3 compartment	800x2000x1200
DC47U8010_M50_SVF80DVR80C2	47U 800X1000 mm, IP20, 80% perforated, single opening front and double opening rear doors, mechanical lock, black, co-location, 2 compartment	800x2200x1000
DC47U8011_M50_SVF80DVR80C2	47U 800X1100 mm, IP20, 80% perforated, single opening front and double opening rear doors, mechanical lock, black, co-location, 2 compartment	800x2200x1100
DC47U8012_M50_SVF80DVR80C2	47U 800X1200 mm, IP20, 80% perforated, single opening front and double opening rear doors, mechanical lock, black, co-location, 2 compartment	800x2200x1200
DC47U8010_M50_SVF80DVR80C3	47U 800X1000 mm, IP20, 80% perforated, single opening front and double opening rear doors, mechanical lock, black, co-location, 3 compartment	800x2200x1000
DC47U8011_M50_SVF80DVR80C3	47U 800X1100 mm, IP20, 80% perforated, single opening front and double opening rear doors, mechanical lock, black, co-location, 3 compartment	800x2200x1100
DC47U8012_M50_SVF80DVR80C3	47U 800X1200 mm, IP20, 80% perforated, single opening front and double opening rear doors, mechanical lock, black, co-location, 3 compartment	800x2200x1200

Note 1: W= 600 mm option is available

Note 2: Color code «M50» is RAL 9005 black, «M2» RAL 7035 light grey option is available..

DCMax Accessories

BOTTOM PANEL

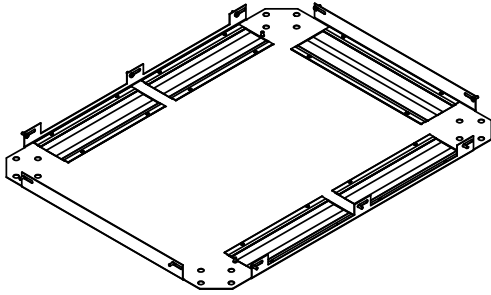

PRODUCT REFERENCE	DESCRIPTION	DIMENSIONS WxD (mm)
DCBP6010_M50	Bottom Panel, multiple cable entry plates, w=600 mm d=1000 mm	600x1000
DCBP6011_M50	Bottom Panel, multiple cable entry plates, w=600 mm d=1100 mm	600x1100
DCBP6012_M50	Bottom Panel, multiple cable entry plates, w=600 mm d=1200 mm	600x1200
DCBP8010_M50	Bottom Panel, multiple cable entry plates, w=800 mm d=1000 mm	800x1000
DCBP8011_M50	Bottom Panel, multiple cable entry plates, w=800 mm d=1100 mm	800x1100
DCBP8012_M50	Bottom Panel, multiple cable entry plates, w=800 mm d=1200 mm	800x1200

PLINTH

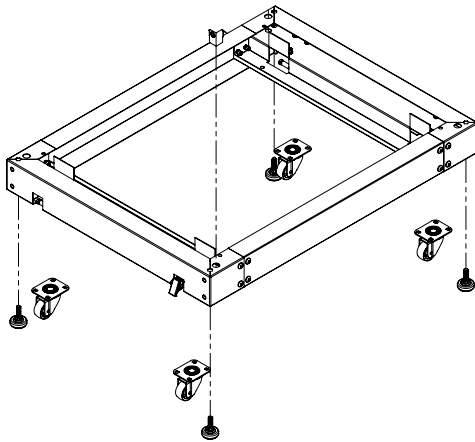

PRODUCT REFERENCE	DESCRIPTION	DIMENSIONS WxD (mm)
DCPLT6010_01M50	Plinth for DCMAX, w= 600 mm d= 1000 mm	600x1000
DCPLT6011_01M50	Plinth for DCMAX, w= 600 mm d= 1100 mm	600x1100
DCPLT6012_01M50	Plinth for DCMAX, w= 600 mm d= 1200 mm	600x1200
DCPLT8010_01M50	Plinth for DCMAX, w= 800 mm d= 1000 mm	800x1000
DCPLT8011_01M50	Plinth for DCMAX, w= 800 mm d= 1100 mm	800x1100
DCPLT8012_01M50	Plinth for DCMAX, w= 800 mm d= 1200 mm	800x1200

CASTERS AND LEVELLING FEET

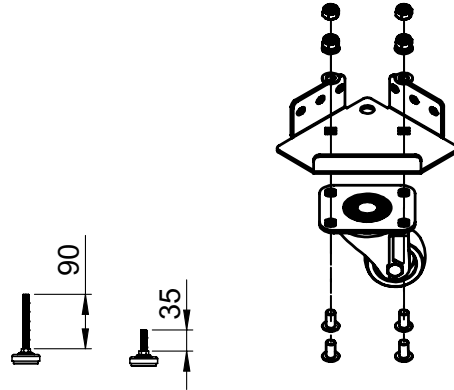

PRODUCT REFERENCE	DESCRIPTION
CST	Castors, 2 pcs. front are lockable
TKRPNYM10X70	M10x70 Levelling feet

RAISED FLOOR SUPPORT KIT

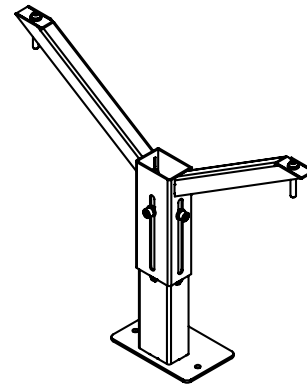

PRODUCT REFERENCE	DESCRIPTION
DCRFSK60_01M50	Raised floor support kit, for the cabinet w=600 mm, adjustable depth= 400-700 mm, 1 set 2 pcs
DCRFSK80_01M50	Raised floor support kit, for the cabinet w=800 mm, adjustable depth= 400-700 mm, 1 set 2 pcs

Note: Color code "M50" is RAL 9005 black, "M2" RAL 7035 light grey option is available.

CABLE MANAGEMENT RINGS

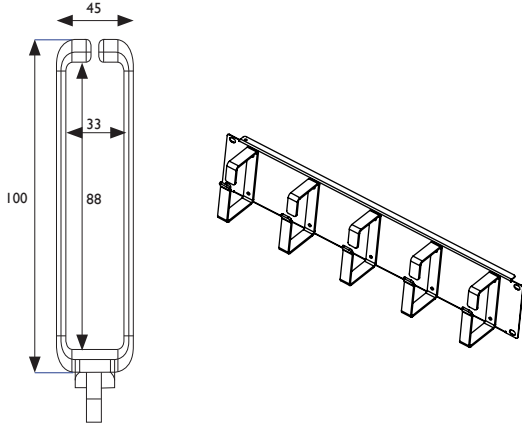

PRODUCT REFERENCE	DESCRIPTION	DIMENSIONS WxH (mm)
K44RING05_01M50	Ring for cable management 45x100mm (1 set = 5 ea.)	45x100
K44RING06_01M50	Ring for cable management 60x100mm (1 set = 5 ea.)	60x100

VERTICAL CABLE MANAGER

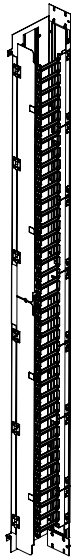

PRODUCT REFERENCE	DESCRIPTION	DIMENSIONS WxHxD (mm)
M78 ORG42	42U Vertical Cable Manager, finger type with metal cover.	92x1885x179
M78 ORG47	47U Vertical Cable Manager, finger type with metal cover.	92x2110x179
DCAFPOR42_M50	Organizer, preventing the air flow, finger type, 42U, w= 800 mm, 2 pcs	108x1885x177
DCAFPOR45_M50	Organizer, preventing the air flow, finger type, 45U, w= 800 mm, 2 pcs	108x1998x177
DCAFPOR47_M50	Organizer, preventing the air flow, finger type, 47U, w= 800 mm, 2 pcs	108x2073x177
M44ORG600_01M50	Bottom Panel, multiple cable entry plates, w=800 mm d=1200 mm	1885x179

Note: Color code "M50" is RAL 9005 black, "M2" RAL 7035 light grey option is available.

BLANK PANELS

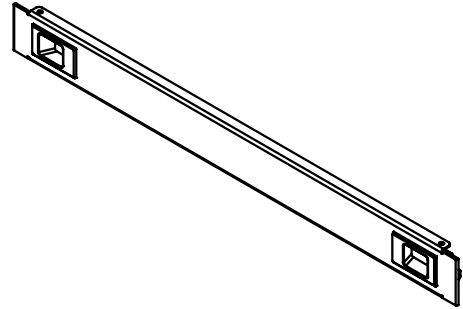

PRODUCT REFERENCE	DESCRIPTION	DIMENSIONS WxHxD (mm)
E44BPN01_0150M	1U 19" Blank panel	483x44x12
E44BPN02_0150M	2U 19" Blank panel	483x88x12
E44BPN03_0150M	3U 19" Blank panel	483x133x12
E44BPN04_0150M	4U 19" Blank panel	483x177x12
E44BPN05_0150M	5U 19" Blank panel	483x222x12
E44BPN06_0150M	6U 19" Blank panel	483x266x12
P44BPN06_01M50	6U 19" Modular plastic blank panel (ABS)	483x266x12

19" KEYBOARD DRAWER

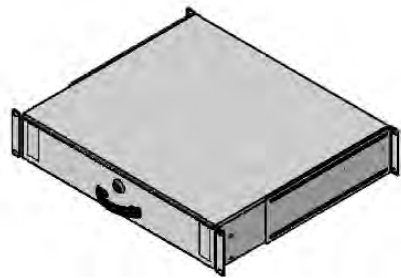

PRODUCT REFERENCE	DESCRIPTION	DIMENSIONS WxHxD (mm)
M44CEK2U_01M50	2U 19" drawer, lockable suitable up to depth=800mm. Cabinets, for D=1000 mm cabinet usage extra brackets available in package, sheet steel material and load carrying capacity is 25 kg.	483x88x400
M44CEK3U_01M50	3U 19" drawer, lockable suitable up to depth=800mm. Cabinets, for D=1000 mm cabinet usage extra brackets available in package, sheet steel material and load carrying capacity is 25 kg.	483x133x400

DCMax Accessories

CABLE TRAYS

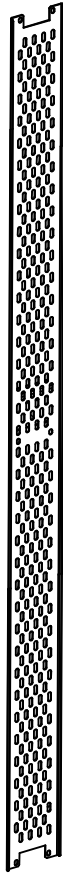

PRODUCT REFERENCE	DESCRIPTION
DCCT4210	Cable Tray, 42U, w= 100 mm
DCCT4510	Cable Tray, 45U, w= 100 mm
DCCT4710	Cable Tray, 47U, w= 100 mm
DCCT4220	Cable Tray, 42U, w= 200 mm
DCCT4520	Cable Tray, 45U, w= 200 mm
DCCT4720	Cable Tray, 47U, w= 200 mm

FIXED AND SLIDING SHELVES

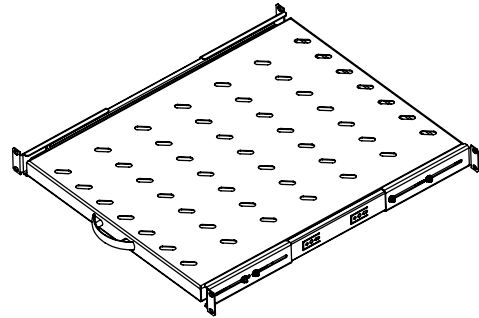

PRODUCT REFERENCE	DESCRIPTION
SHLFIX60M50	D= 600 mm fixed shelf module with slots, load capacity 50 kg., Ral9005, depth of the shelf D= 372 mm, 4-points fixed. Only suitable for 600 mm depth cabinets.
SHLFIX80M50	D= 800 mm fixed shelf module with slots, load capacity 50 kg., Ral9005, depth of the shelf D= 530 mm, 4-points fixed. Only suitable for 800 mm depth cabinets.
SHLFIX100M50	D= 1000 mm fixed shelf module with slots, load capacity 50 kg., Ral9005, depth of the shelf D= 696 mm, 4-points fixed. Only suitable for 1000 mm depth cabinets.
SHLSLD60M50	D= 600 mm sliding shelf module with slots, load capacity 30 kg., Ral9005, depth of the shelf D= 372 mm, 4-points fixed. Only suitable for 600 mm depth cabinets.
SHLSLD80M50	D= 800 mm sliding shelf module with slots, load capacity 30 kg., Ral9005, depth of the shelf D= 530 mm, 4-points fixed. Only suitable for 800 mm depth cabinets.
SHLSLD100M50	D= 1000 mm sliding shelf module with slots, load capacity 30 kg., Ral9005, depth of the shelf D= 696 mm, 4-points fixed. Only suitable for 1000 mm depth cabinets.

FIXINGS

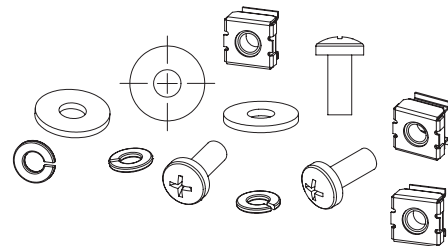

PRODUCT REFERENCE	DESCRIPTION
KFS6X15_20	M6 caged nut, screw, washer (1set=20ea)
KFS6X15_50	M6 caged nut, screw, washer (1set=50ea)

Note: Color code "M50" is RAL 9005 black, "M2" RAL 7035 light grey option is available

FAN MODULES

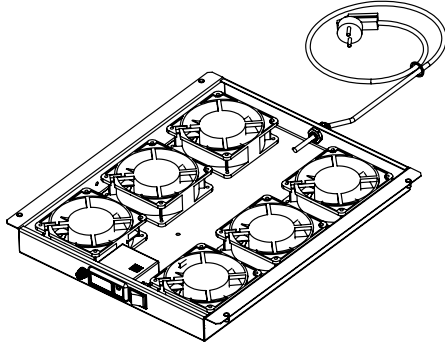

PRODUCT REFERENCE	DESCRIPTION
FAN4DT4F01_M50	Fan module, 4 fan + digital thermostat, 2P+E plug, schuko std., 4 pre-cut hole
FAN4DT4F02_M50	Fan module, 4 fan + digital thermostat, 2P+E plug, UK std., 4 pre-cut hole
FAN4O04F01_M50	Fan module, 4 fan + On/Off, 2P+E plug, schuko std., 4 pre-cut hole
FAN4O04F02_M50	Fan module, 4 fan + On/Off, 2P+E plug, UK std., 4 pre-cut hole
FAN4AT4F01_M50	Fan module, 4 fan + analog thermostat, 2P+E plug, schuko std., 4 pre-cut hole
FAN4AT4F02_M50	Fan module, 4 fan + analog thermostat, 2P+E plug, UK std., 4 pre-cut hole
FAN6DT6F01_M50	Fan module, 6 fan + digital thermostat, 2P+E plug, schuko std., 6 pre-cut hole
FAN6DT6F02_M50	Fan module, 6 fan + digital thermostat, 2P+E plug, UK std., 6 pre-cut hole
FAN6O06F01_M50	Fan module, 6 fan + On/Off, 2P+E plug, schuko std., 6 pre-cut hole
FAN6O06F02_M50	Fan module, 6 fan + On/Off, 2P+E plug, UK std., 6 pre-cut hole
FAN6AT6F01_M50	Fan module, 6 fan + analog thermostat, 2P+E plug, schuko std., 6 pre-cut hole
FAN6AT6F02_M50	Fan module, 6 fan + analog thermostat, 2P+E plug, UK std., 6 pre-cut hole

GROUNDING KIT

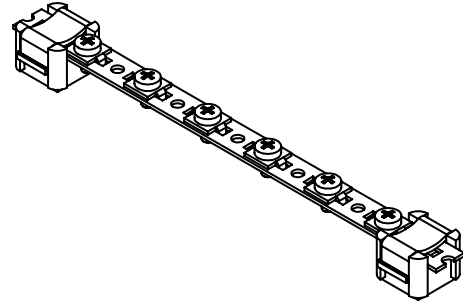

PRODUCT REFERENCE	DESCRIPTION
M44PEB01	Grounding kit, 6 each earthing leads + copper busbar
M44PEB19_01	Grounding kit, 13 each earthing leads + copper busbar

PDU HOLDER

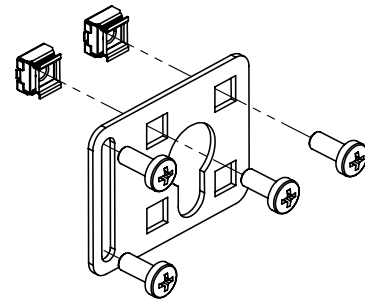

PRODUCT REFERENCE	DESCRIPTION
DCPDUHM01_M50	PDU holder, 1 set= 2 pcs, for 1 PDU
DCPDUHM02_M50	PDU holder, 1 set= 2 pcs, for 2 PDU

DCMax Corridor Solutions

TOP PANEL

Easy fixing top panel is used for closing the top of hot/cold aisle containment. Polycarbonate (4 mm) closing with reinforced metal frame. Glass option is available.

TOP COVER CABLE SEPARATOR (A TYPE)

DCMax cabinets offer professional and highly secured management of high density data and power cables. M Type separator have h=200 mm. and w=600/800 mm. options.

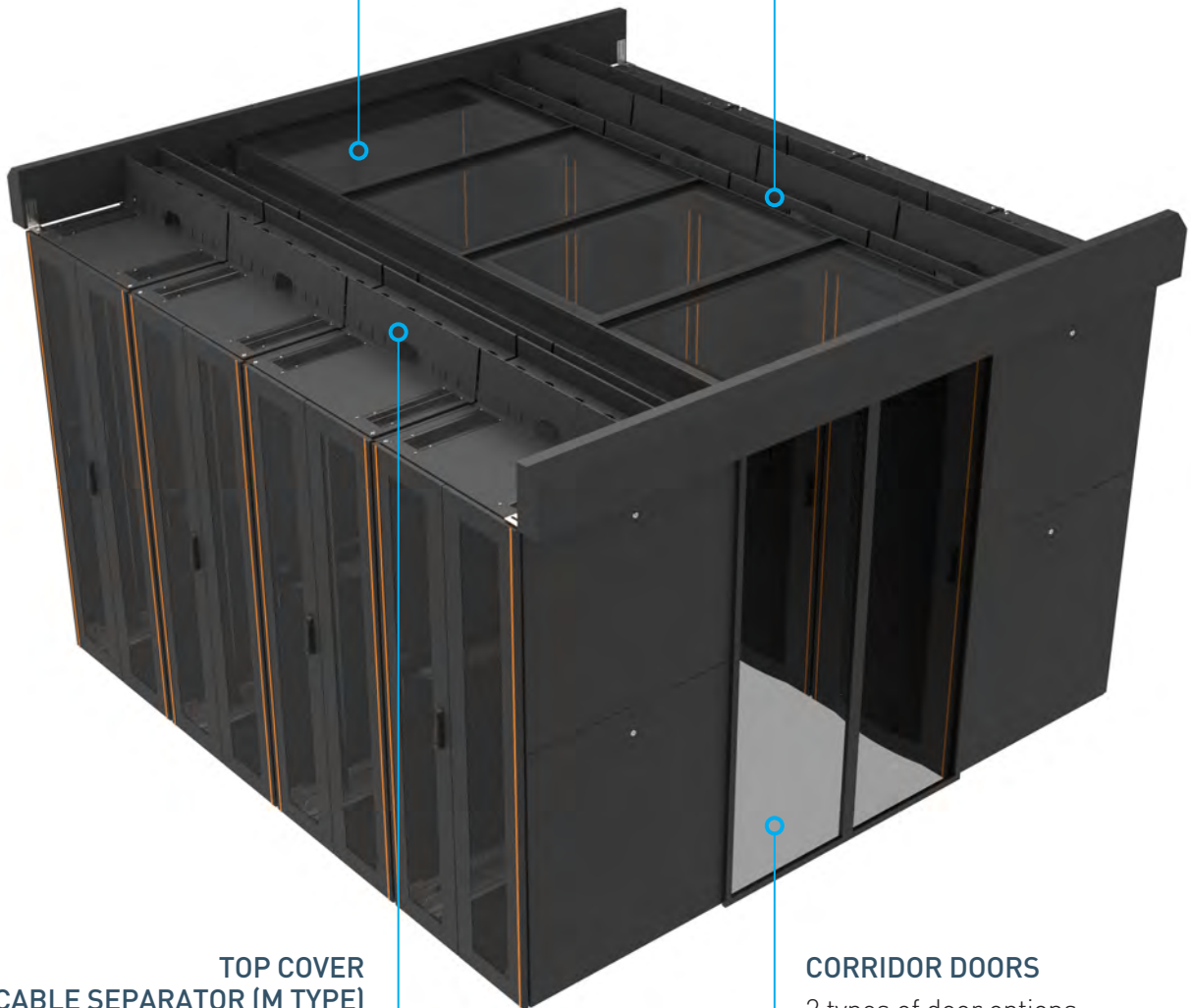

TOP COVER CABLE SEPARATOR (M TYPE)

Separate cable inlet for data and energy cables, and separate overhead cable trays and dividers minimize the electromagnetic and physical interference. A type separator have h=120 mm. and w=600/800 mm. options.

CORRIDOR DOORS

2 types of door options are available as automatic opening and manual opening. Dimensions: 42/45/47U 600 or 1200/1500/1800 mm. Automatic door opening and exit with hand sensor. Keypad or proximity card lock is available. Lock to the bottom option is suitable for manual opening.

AUTOMATIC OPENING

Wing Frame Material: Aluminium.
Glass: 4+4mm transparent laminated glass.
Carrier System: 5 x 60 x 120mm – 4x brackets; 40 x 60 x 2mm Alm. Profile posts.
Carrier wide: 3200mm – 3600mm*
Security Sensor: Active 8 curtain photocell sensor.
Mechanism Wide: 2500mm.
Corridor Wide: 1200 x 2240mm.
Wings: 2 x moving wings, automatic.
Locking: Electro-mechanic locking systems.
Locking Options: Keypad or Proximity Card.
Colour: RAL 9005 and RAL 7035.

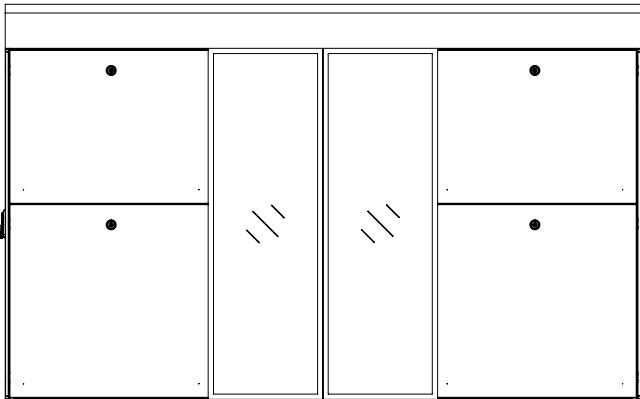

MANUEL OPENING

Wing Frame Material: Aluminium.
Glass: 4+4mm transparent laminated glass.
Carrier System: 5 x 60 x 120mm – 4x brackets; 40 x 60 x 2mm Alm. Profile posts.
Carrier Wide: 3200mm – 3600mm*
Mechanism Wide: 2500mm
Corridor Wide: 1200mm
Wings: 2 x synchronized wings.
Locking: Lock to the bottom.
Colour: RAL 9005 and RAL 7035

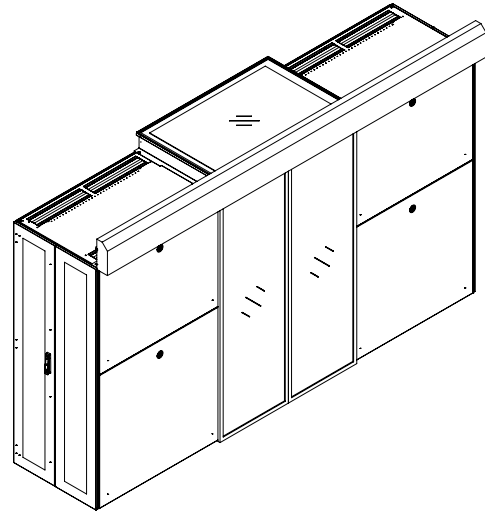

*Depends to the cabinets depth.

PRODUCT REFERENCE	DESCRIPTION
DCCD4212_01M50	42U Corridor door, double opening, w= 1200 mm, tempered glass, opening and exit with hand sensor
DCCD4215_01M50	42U Corridor door, double opening, w= 1500 mm, tempered glass, opening and exit with hand sensor
DCCD4218_01M50	42U Corridor door, double opening, w= 1800 mm, tempered glass, opening and exit with hand sensor
DCCD4512_01M50	45U Corridor door, double opening, w= 1200 mm, tempered glass, opening and exit with hand sensor
DCCD4515_01M50	45U Corridor door, double opening, w= 1500 mm, tempered glass, opening and exit with hand sensor
DCCD4518_01M50	45U Corridor door, double opening, w= 1800 mm, tempered glass, opening and exit with hand sensor
DCCD4712_01M50	47U Corridor door, double opening, w= 1200 mm, tempered glass, opening and exit with hand sensor
DCCD4715_01M50	47U Corridor door, double opening, w= 1500 mm, tempered glass, opening and exit with hand sensor
DCCD4718_01M50	47U Corridor door, double opening, w= 1800 mm, tempered glass, opening and exit with hand sensor

Note 1: Color code "M50" is RAL 9005 black, "M2" RAL 7035 light grey option is available.

Note 2: For the entrance and/or exit of the sliding doors by push button or any kind of access options please refer to the sales office.

DCMax Corridor Solutions

TOP PANEL MODULE (4MM)

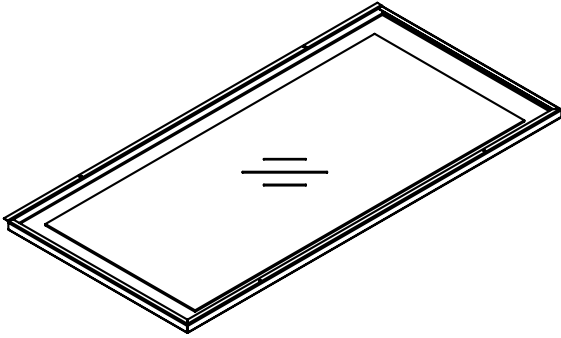

PRODUCT REFERENCE	DESCRIPTION
DCTP6012_01M50	Top panel module, 600X1200 mm
DCTP6012_02M50	Top panel edge module, 600X1200 mm
DCTP6015_02M50	Top panel edge module, 600x1500 mm
DCTP6015_01M50	Top panel module, 600X1500 mm
DCTP8012_01M50	Top panel module, 800X1200 mm
DCTP8012_02M50	Top panel edge module, 800X1200 mm
DCTP8015_02M50	Top panel edge module, 800X1500 mm
DCTP8015_01M50	Top panel module, 800X1500 mm
DCTP8018_02M50	Top panel edge module, 800X1800 mm
DCTP8018_01M50	Top panel module, 800X1800 mm

TOP COVER CABLE SEPERATOR (A AND M TYPE)

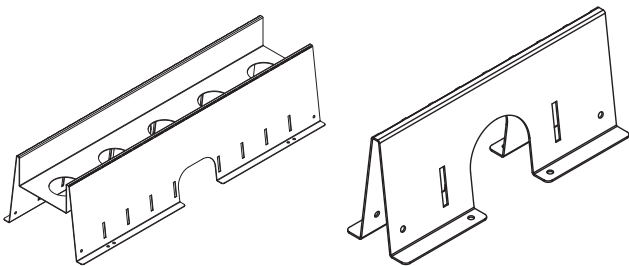

PRODUCT REFERENCE	DESCRIPTION
DCTCCS6012_01M50	01M50 Top cover cable seperator, h= 120 mm, w= 600 mm, A type
DCTCCS8012_01M50	Top cover cable seperator, h= 120 mm, w= 800 mm, A type
DCTCCS6020_02M50	Top cover cable seperator, h= 200 mm, w= 600 mm, M type
DCTCCS8020_02M50	Top cover cable seperator, h= 200 mm, w= 800 mm, M type

CORRIDOR DOOR FIXING MODULE

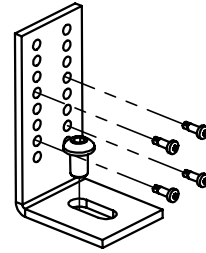

PRODUCT REFERENCE	DESCRIPTION
DCCDFM_02M50	Corridor door fixing module, 8 cm top cover panel

BAYING KIT AND BLANK MODULES

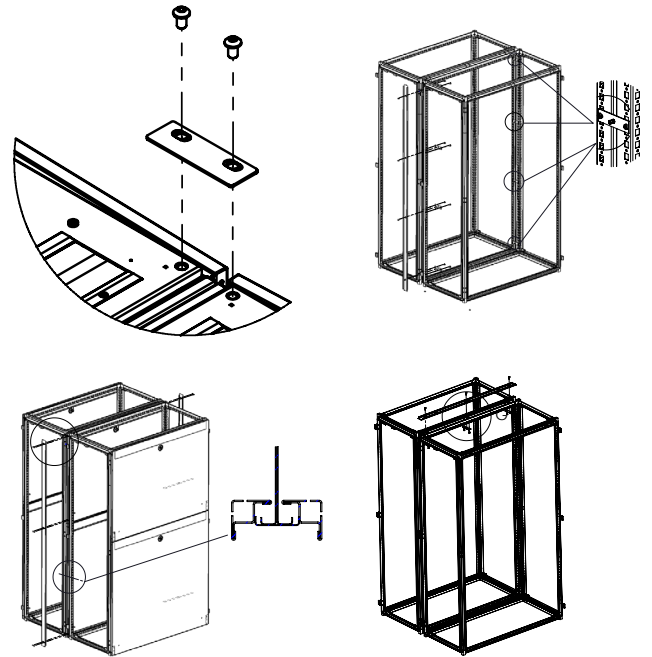

PRODUCT REFERENCE	DESCRIPTION
DCBK_01M50	Baying kit, 1 set= 2 pcs.
DCBM42_01M50	Blank module, 42U, without side panel
DCBM45_01M50	Blank module, 45U, without side panel
DCBM47_01M50	Blank module, 47U, without side panel
DCBM42_02M50	Blank module, 42U, with side panel
DCBM45_02M50	Blank module, 45U, with side panel
DCBM47_02M50	Blank module, 47U, with side panel
DCBM42_03M50	Blank module, 42U, without side panel depth
DCBM45_03M50	Blank module, 45U, without side panel depth
DCBM47_03M50	Blank module, 47U, without side panel depth

Note: Baying kit option of «02M50» code is for profile baying kit

Note: Color code "M50" is RAL 9005 black, "M2" RAL 7035 light grey option is available

CORRIDOR REAR PANEL MODULES

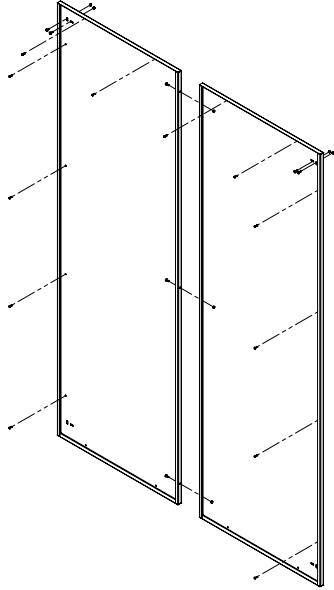

PRODUCT REFERENCE	DESCRIPTION
DCCRPM4212_01M50	Corridor rear panel modules, 42U, h=1200 mm
DCCRPM4215_01M50	Corridor rear panel modules, 42U, h=1500 mm
DCCRPM4218_01M50	Corridor rear panel modules, 42U, h=1800 mm
DCCRPM4712_01M50	Corridor rear panel modules, 47U, h=1200 mm
DCCRPM4715_01M50	Corridor rear panel modules, 47U, h=1500 mm
DCCRPM4718_01M50	Corridor rear panel modules, 47U, h=1800 mm

TOP COVER PANEL

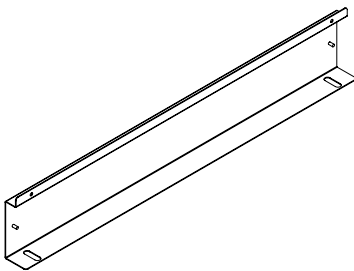

PRODUCT REFERENCE	DESCRIPTION
DCTCP6012_M50	Top cover panel, w= 600 mm, h= 120 mm
DCTCP8012_M50	Top cover panel, w= 800 mm, h= 120 mm

AIRFLOW PREVENTATIVE PANEL



PRODUCT REFERENCE	DESCRIPTION
DCAFPTBP4260_M50	Airflow preventative panel, 42U, w=600 mm, top and bottom
DCAFPTBP4280_M50	Airflow preventative panel, 42U, w=800 mm, top and bottom
DCAFPTBP4780_M50	Airflow preventative panel, 47U, w=800 mm, top and bottom
DCAFSP4260_M50	Airflow preventative panel, 42U, w=600 mm, side
DCAFSP4560_M50	Airflow preventative panel, 45U, w=600 mm, side
DCAFSP4760_M50	Airflow preventative panel, 47U, w=600 mm, side
DCAFSP4280_M50	Airflow preventative panel, 42U, w=800 mm, side
DCAFSP4580_M50	Airflow preventative panel, 45U, w=800 mm, side
DCAFSP4780_M50	Airflow preventative panel, 47U, w=800 mm, side

Note: Color code "M50" is RAL 9005 black, "M2" RAL 7035 light grey option is available

DCMax

TECHNICAL CHARACTERISTICS

MAIN STRUCTURE

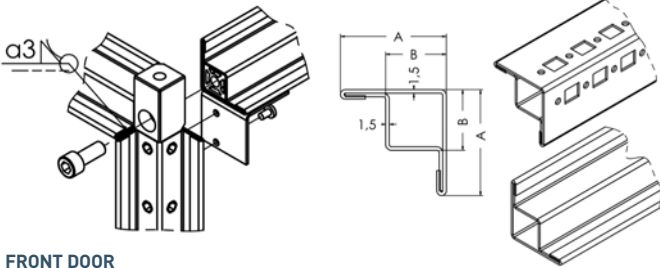

FRONT DOOR STRUCTURE:

- Produced from galvanised sheet metal.
- The curved door has 80% perforations to have a good air flow.
- Provides enough space for patch cords between door and equipment.
- Can open 130°

LOCKING MECHANISM:

3 point lock, handle with semi cylindrical barrel.

HINGE SYSTEM: 3 pcs Zinc alloy Steel to fix the door.

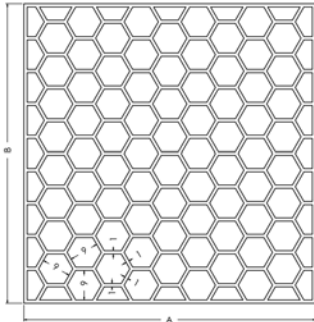

SIDE PANEL STRUCTURE:

- Produced from DKP sheet metal.
- Thickness is 1 mm.
- Fixed to cabinet by cylindrical lock.
- 2 pcs in one side.

REAR DOOR STRUCTURE:

- Produced from DKP sheet metal.
- The flat door has 80% perforations to have a good air flow.
- Can open 130°.

LOCKING MECHANISM:

3 point lock, handle with semi cylindrical barrel

HINGE SYSTEM:

3 pcs Zinc alloy Steel to fix the door.

ROOF STRUCTURE:

- Produced from DKP sheet metal.
- Suitable to fan module fixing.
- Plenty of cable entry possibility.
- Brush type cable entries.

TESTS AND COMPLIED STANDARDS

TESTS AND COMPLIED STANDARDS

- 1) ISO 9001:2015 Quality Management System
- 2) ISO 14001:2015 Environmental Management System
- 3) ISO 27001:2013 Information Security Management System
- 4) ISO 45001:2018 Occupational Health and Safety Management System
- 5) 19" device mounting uprights IEC 297-1
- 6) EN 61587-1 Mechanical structures for electronic equipment.
- 7) All cabinet sizes complies with IEC 297-2.

**RESISTANCE TO ENVIRONMENTAL CONDITIONS AND CORROSION;
STABILITY, MECHANICAL SAFETY, RESISTANCE TO STATIC, DYNAMIC AND MECHANICAL LOADS;
RESISTANCE TO VIBRATION, MECHANICAL SHOCK AND IMPACT;
DEGREES OF MECHANICAL PROTECTION PROVIDED BY THE ENCLOSURE (IP20);
ELECTRICAL GROUNDING CONTINUITY;
FIRE AND FLAME RESISTANCE;**

Have been tested according to the standard " EN 61587-1" with the normative standards: IEC 60917, IEC 60297, IEC 60068-1, IEC 60068-2, IEC 60695-11-10, IEC 60950-1, contained and certified by the notified organizations::

TSE CERTIFICATE NO

003788-TSE-08/02

EAC CERTIFICATE NO

0443637, 0776963, 0345864, 0401678, 0776653

CORROSION

ISO 9227 Standard complied by the test report METALTEK AB-0547-T / 0157-1

SEISMIC TESTS

BELLCORE GR-63-CORE ZONE 4, NEBS requirements Standart complied by the test report SOPEMEA EHL 14680 JAN 2010

TRANSPORT

ETS 300 019-1-2 Class 2.3 Comply with internal testing

STORAGE

ETS 300 019-1-1 Class 1.2 Comply with internal testing

SURFACE FINISH

Electrostatic powder coated c/with surface treatment , 80 +/- 5 micron paint thickness

PURCHASED PRODUCT CERTIFICATION

SHEET STEEL

EN 10346: 20015 DX51D+Z, EN 10130: 2006 DC01

ELECTROSTATIC POWDER COATING

ISO6860, ISO2409, ISO1520, ISO2815, ISO6272, ISO7253, ISO6270-1, ISO2812
ISO 9001, RoHS

GLASS

TS EN 12150-1, TS EN 1863-1

LOCK

IEC 62474, REACH, RoHS

CASTORS

ISO 9001, TS EN 12532, RoHS

FAN

IEC 60335-2-80:2002, IEC 60335-1:2010



“High performance”
now has a name:



DCMax

DCMax cabinets with perfect and aesthetic design for hot and cold corridors provide reliable, flexible and scalable high performance for critical data center infrastructures.

ServerMax

Intro

ServerMax cabinets maximize the performance of high value technological investments.

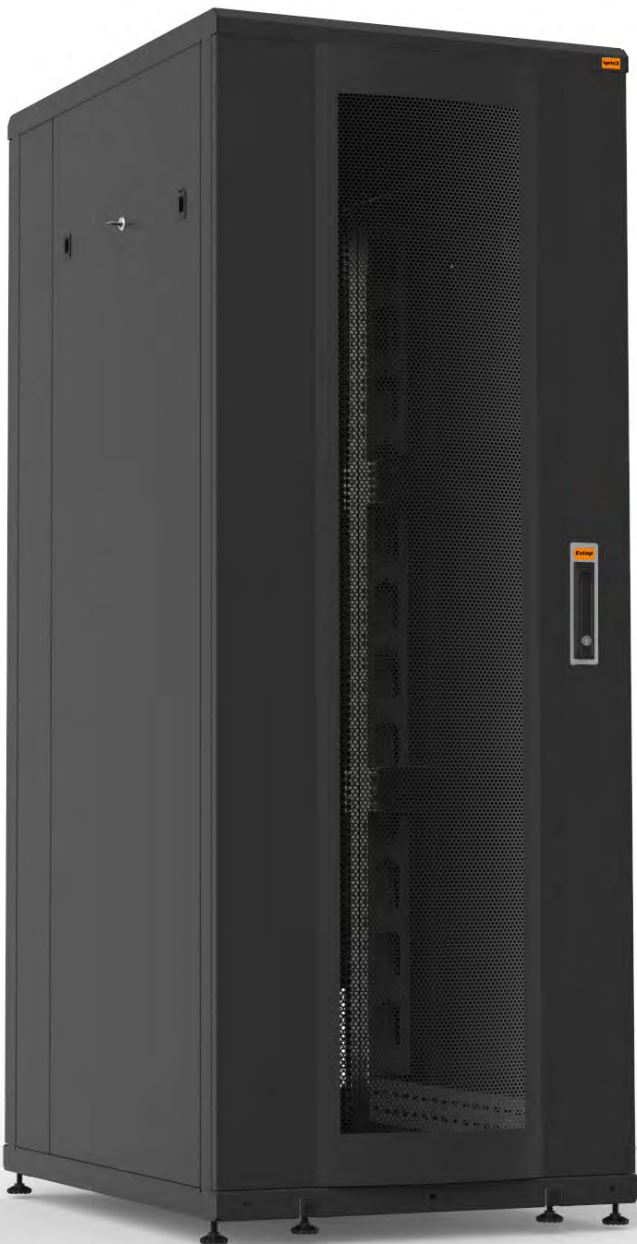

GENERAL CHARACTERISTICS

- Compliments your decor and environment
- Secure and sturdy
- Excellent passive air ventilation
- Wide range of sizes; 26U, 36U, 42U, 47U
- Depth sizes; 1000 mm. and 1200 mm
- Width sizes; 600 mm. and 780 mm
- 1000 kg load carrying capacity
- Useful and high internal volume
- High stability with standard 2 sliding type tilt bars
- Casters+ leveling feet as standard
- Floor fixing, plinth and baying kit options
- 115° openable front and 215° openable rear doors
- Standard colors, RAL 9005 Black & RAL 7035 Light Grey
- IP 20 protection standard
- Depth adjustable 19" mounting uprights even when the cabinet is fully loaded
- Multiple brushed cable entries on top and the bottom of the cabinet



SECURE HOUSING FOR ALL EIA-310 COMPLIANT ACTIVE EQUIPMENTS

Compatible with all EIA-310 compliant 19" equipment. All type of servers, brands will physically fit in ServerMAX server cabinet.

- L profile mounting rails have strong and adjustable structure, square holes in full length
- Numbered U positions facilitate easy installation of rack mounted equipment
- 3-point, swing handle door locking mechanism: high security for unauthorized access
- Strong protection against physical damage
- 63% perforated, 215 degrees opening, swappable doors (80% option available)
- Curved single front door for cabling flexibility and aesthetics
- Double rear doors for easy handling
- Lockable and removable side panels for improved security
- Removable bottom parts
- Reliable fan tray options; equipped with up to 6 x fans, on/off button, fuse, analog or digital thermostat & wired mesh fences



ServerMax

DIMENSIONS

PRODUCT REFERENCE*	PRODUCT DEFINITION (mm)	"U" HEIGHT	DEPTH OVERALL	DEPTH MAX MOUNTING PROFILE	HEIGHT VERTICAL MOUNTING PROFILE	HEIGHT WITHOUT LEVELLING FEET	HEIGHT WITH LEVELLING FEET MIN	HEIGHT WITH CASTERS
SRV26U60...	26U 600x1000	26	600	1000	740	1175	1309	1389
SRV36U60...	36U 600x1000	36	600	1000	740	1620	1754	1834
SRV42U60...	42U 600x1000	42	600	1000	740	1890	2002	2049
SRV47U60...	47U 600x1000	47	600	1000	740	2112	2224	2271
SRV26U80...	26U 780x1000	26	780	1000	740	1175	1309	1389
SRV36U80...	36U 780x1000	36	780	1000	740	1620	1754	1834
SRV42U80...	42U 780x1000	42	780	1000	740	1890	2002	2049
SRV47U80...	47U 780x1000	47	780	1000	740	2112	2224	2271



* Pls complete the reference code referring the "Reference Code Creation" on next page.
 * D=1200 mm option is available. For different U heights please refer to our sales office.

DOOR SELECTION TABLE

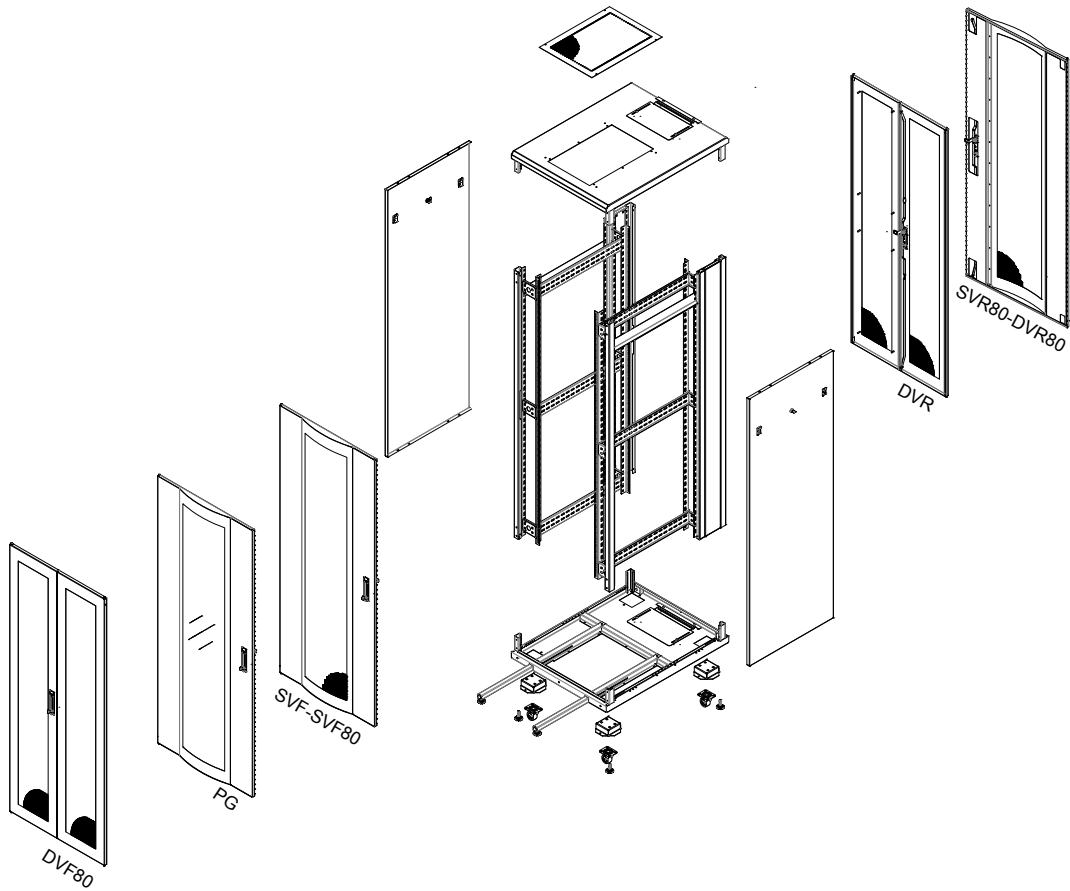

Door Code	Description	W
FRONT		
PG	Single, Curved Frame Plexi-Glass front Door, single point locking	Optional
SVF	Single Vented Front Door, 63% perforated, single point locking	Standard
SVF80	Single Vented Front Door, 80% perforated, single point locking	Optional
DVF80	Double Vented Front Door, 80% perforated, three point locking	Optional
REAR		
DVR	Double Vented Rear Door, 63% perforated, three point locking	Standard
SVR80	Single Vented Rear Door, 80% perforated, single point locking	Optional
DVR80	Double Vented Rear Door, 80% perforated, three point locking	Optional

 Marked are also Default Config.

REFERENCE CODE CREATION

Example:

SRV42U80_03M2_PNY_DVF80DVR80

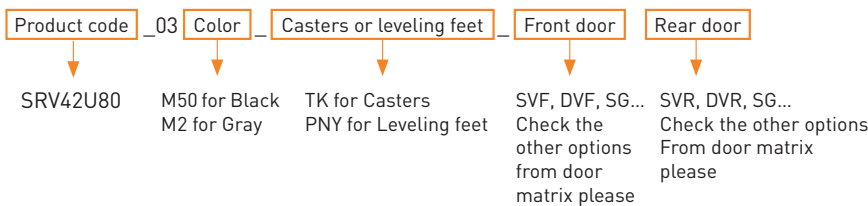

ServerMax

TECHNICAL DRAWINGS W=600 mm CABINETS

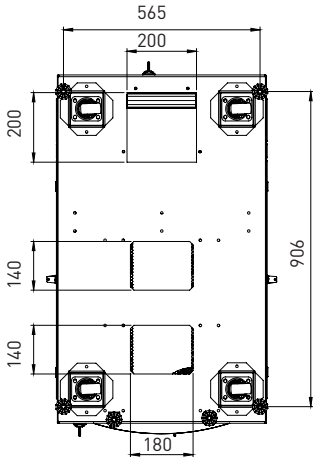

Bottom view

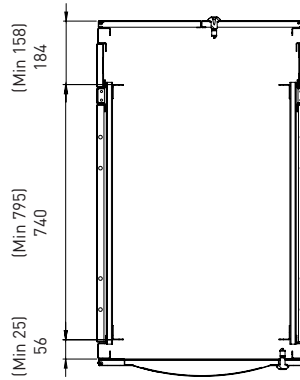

Mounting profile

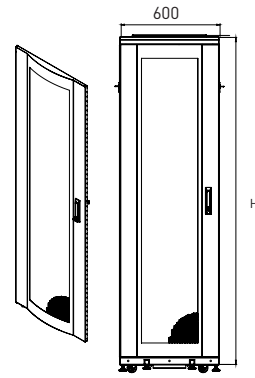

Front view

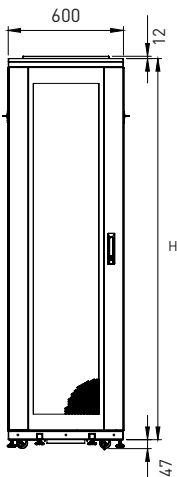

Front view

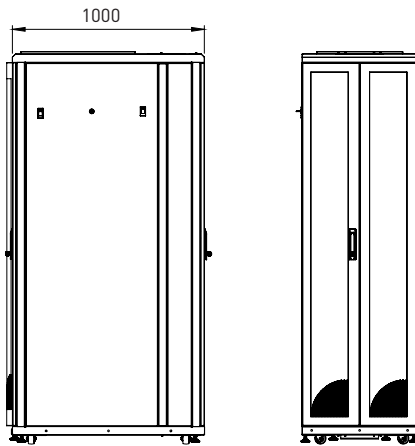

Side view

Back view

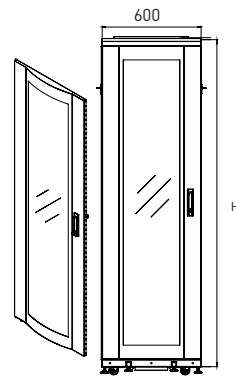

Front view

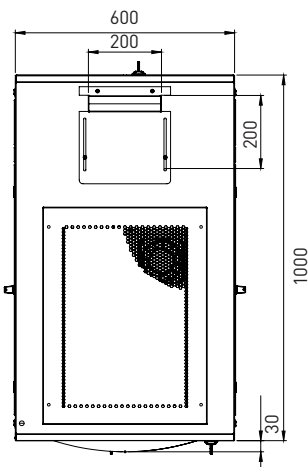

Top view

H= Enclosure height

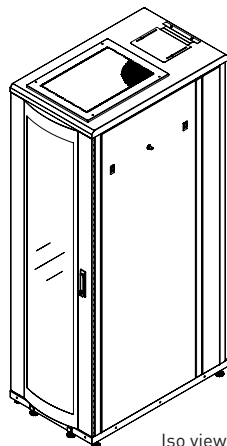

Iso view

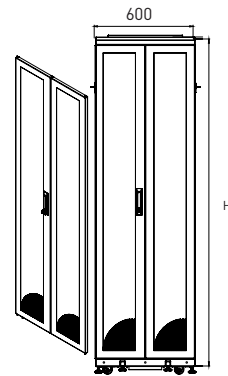

Front view

TECHNICAL DRAWINGS

W=800 mm CABINETS

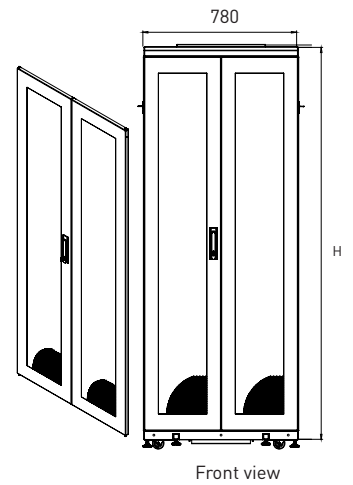
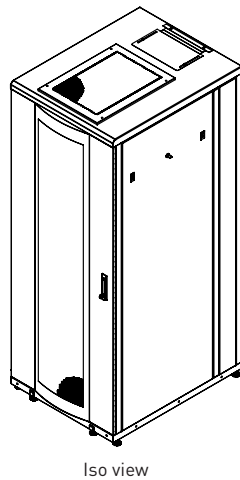
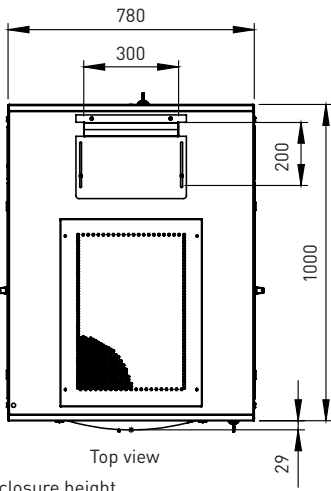
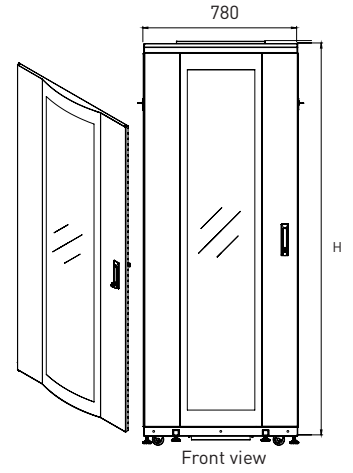
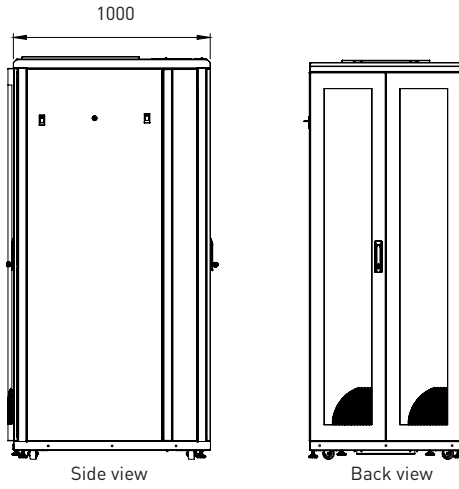
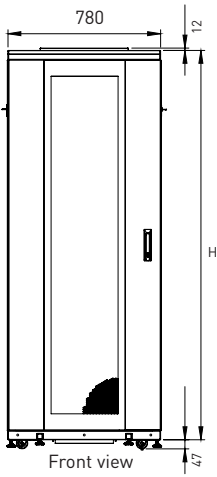
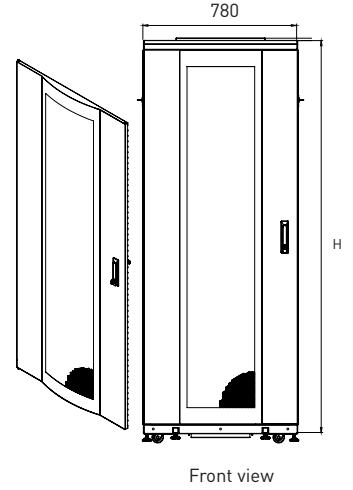
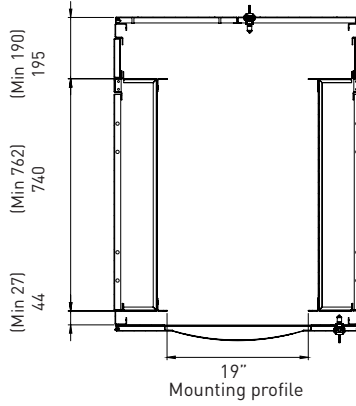
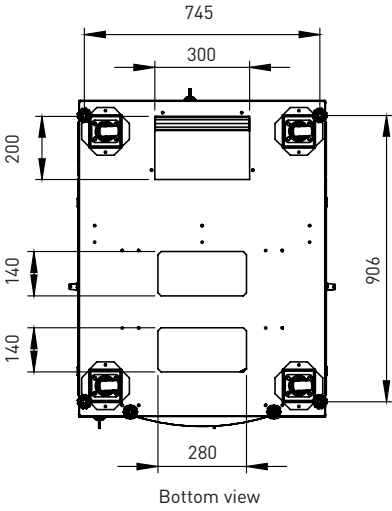

H= Enclosure height

ServerMax

TECHNICAL DRAWINGS

EXTENTION UNIT D= 200mm for 600X1000mm CABINETS

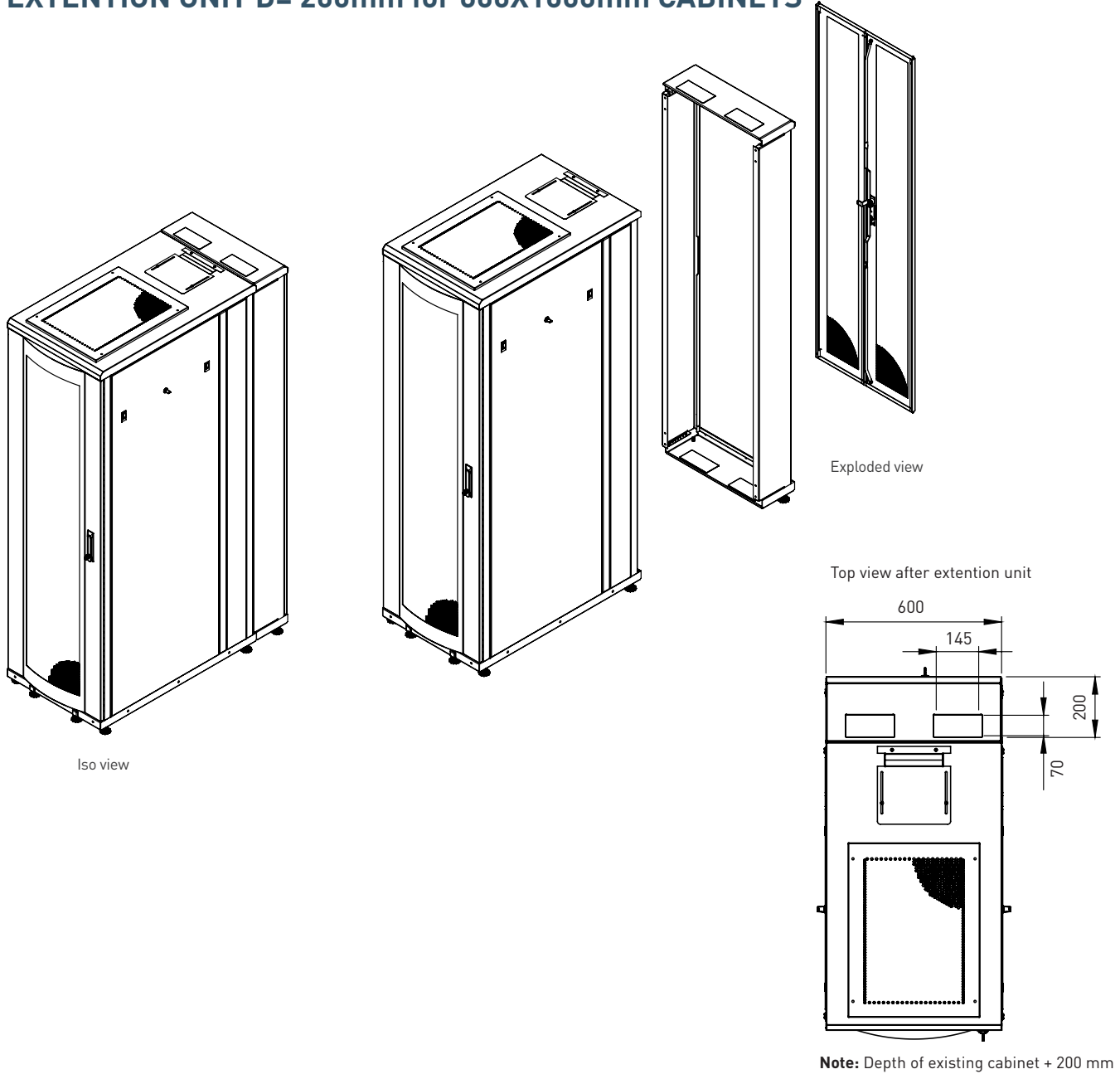

PRODUCT REFERENCE*	PRODUCT DEFINITION (mm)	U SIZE (mm)	WIDTH OVERALL (mm)	DEPTH OVERALL (mm)	HEIGHT WITHOUT LEVELLING FEET (mm)	HEIGHT WITH CASTERS (mm)
SRV26UEXT620_03M50	26U Extension unit D=200 mm, suitable for ServerMAX W=600 mm	26	600	200	1281	1328
SRV36UEXT620_03M50	36U Extension unit D=200 mm, suitable for ServerMAX W=600 mm	36	600	200	1726	1773
SRV42UEXT620_03M50	42U Extension unit D=200 mm, suitable for ServerMAX W=600 mm	42	600	200	1993	2040
SRV47UEXT620_03M50	47U Extension unit D=200 mm, suitable for ServerMAX W=600 mm	47	600	200	2215	2262

* For different U heights please refer to our sales office.

Note: Color code "M50" is RAL 9005 black, "M2" RAL 7035 light grey option is available

TECHNICAL DRAWINGS

EXTENTION UNIT D= 200mm for 780X1000mm CABINETS

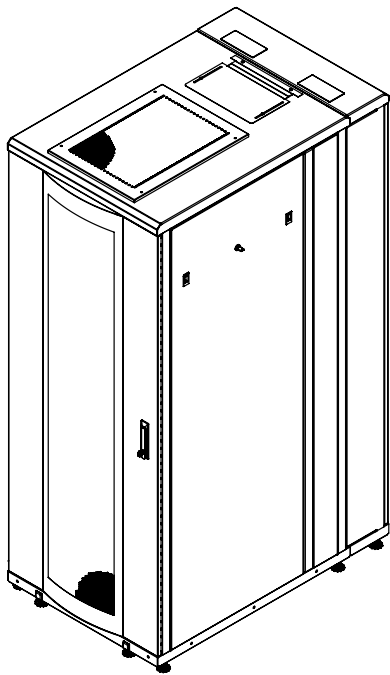

Iso view

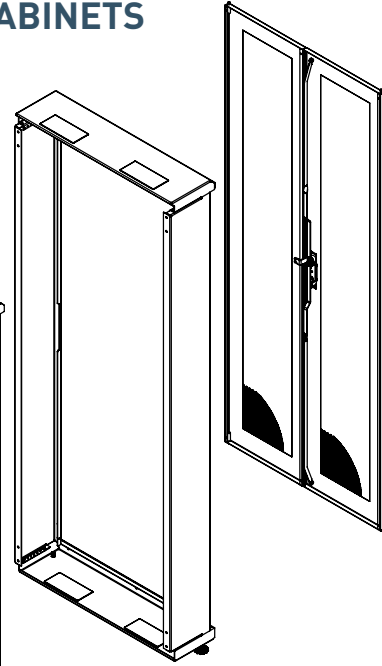
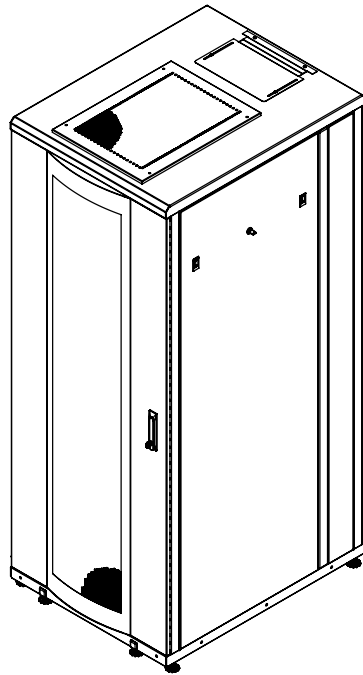

Exploded view

Top view after extension unit

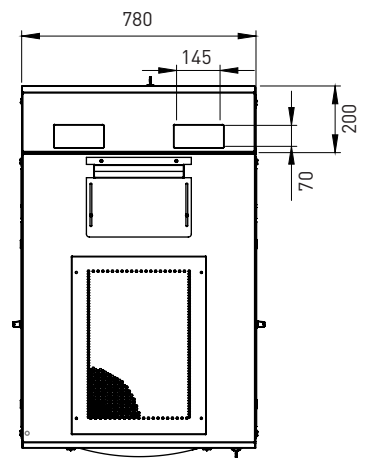

Note: Depth of existing cabinet + 200 mm

PRODUCT REFERENCE*	PRODUCT DEFINITION (mm)	U SIZE (mm)	WIDTH OVERALL (mm)	DEPTH OVERALL (mm)	HEIGHT WITHOUT LEVELLING FEET (mm)	HEIGHT WITH CASTERS (mm)
SRV42UEXT820_03M50	42U Extention unit D=200 mm, suitable for ServerMAX W=780 mm	42	780	200	1993	2040
SRV47UEXT820_03M50	47U Extention unit D=200 mm, suitable for ServerMAX W=780 mm	47	780	200	2215	2262

* For different U heights please refer to our sales office.

Note: Color code "M50" is RAL 9005 black, "M2" RAL 7035 light grey option is available

19" FREE-STANDING RACK CABINETS

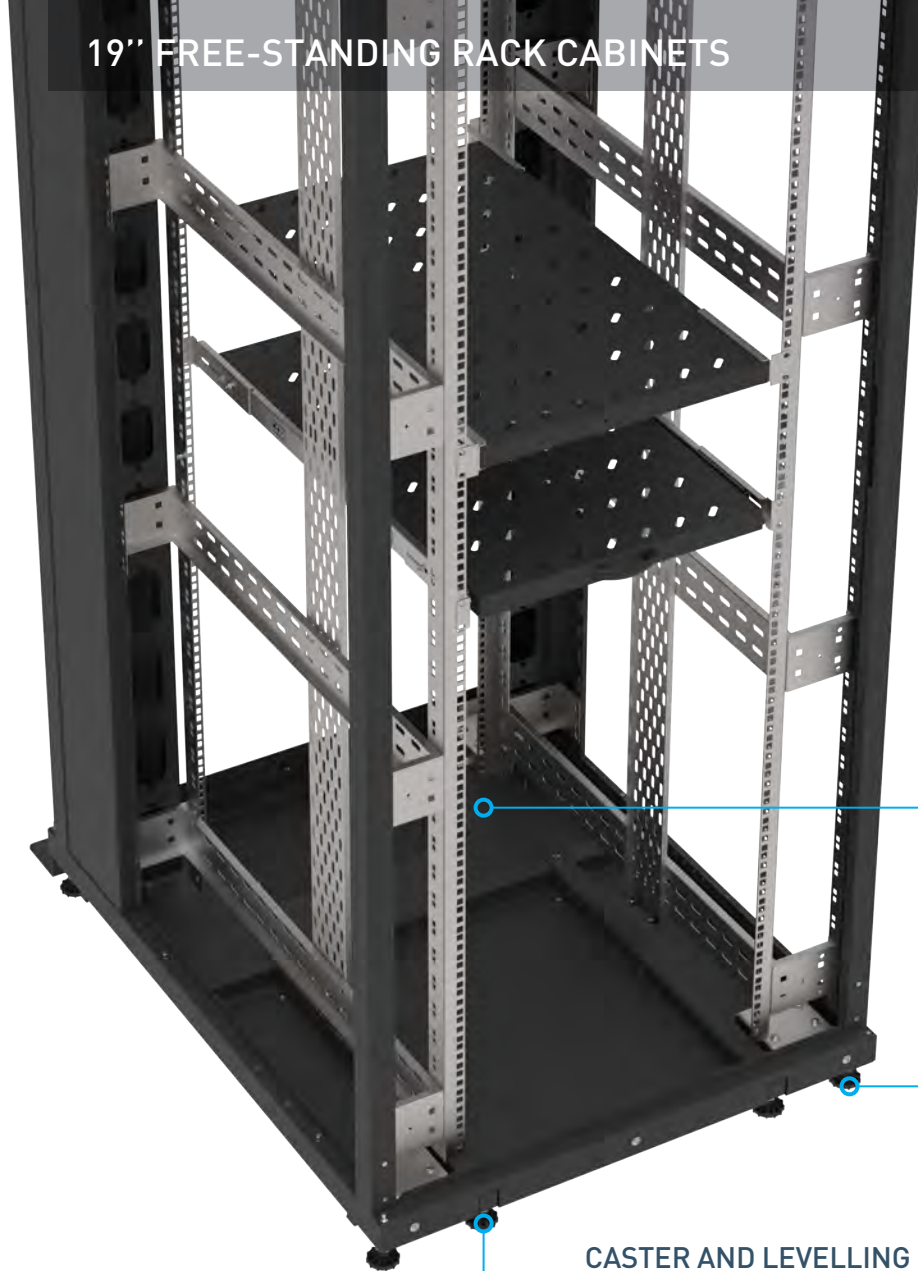

TILTING BAR

As standard, ServerMAX is fitted with 2 sliding type tilt bars to make the cabinet stable in weight center. Whenever the servers are moved out, tilt bars are drawn out to counter-balance the cabinets weight center.

CASTER AND LEVELLING FEET

Rotational type casters, 2 pieces front have lockable function
Levelling feet: Height adjustment from the floor 250 kg. load carrying capacity of each wheel and each levelling feet.

FAN MODULE

2 or 4 pcs. of fan on a module, with ON/OFF, analog or digital thermostat functions. Complete inner wiring. 1U.

LED LIGHT

Effective and powerful lighting.
Different dimensions 19", 1U, with ON/OFF switch, automatic door with ON/OFF switch or LED with sensor.

GROUNDING CONTINUITY

Grounding cables for all metal components. Cable connections with bolts and nuts for all doors.

ServerMax Accessories

VERTICAL CABLE ORGANIZER

Options from 26U to 47U. Large internal volume that protects all kind of electric and data cables and patch cords. It must have a large internal volume that can protect all kind of electric and data cables and patch cords. It attaches to the sides along 19" uprights and have cable entry holes.

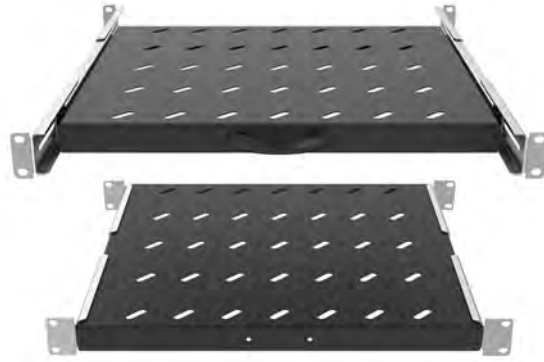

FIXED AND SLIDING SHELF

Fixing points at the sides of rear and front 19" uprights.

Vented for air circulation, adjustable depth, sheet steel material. Available for all kind of cabinet depths like 600mm, 800mm and 1000mm.

SLIDING TYPE CABLE ENTRIES

Cable access holes are provided in the top and bottom panels. One on top, one on bottom holes are special ESTAP style cable entries; sliding type with rubber edges.

CABLE TRAY

Options from 26U to 47U. The galvanized coating must be perforated to provide length and cable installation along the height of the cabinet. Unified cable tray for every cabinet range.

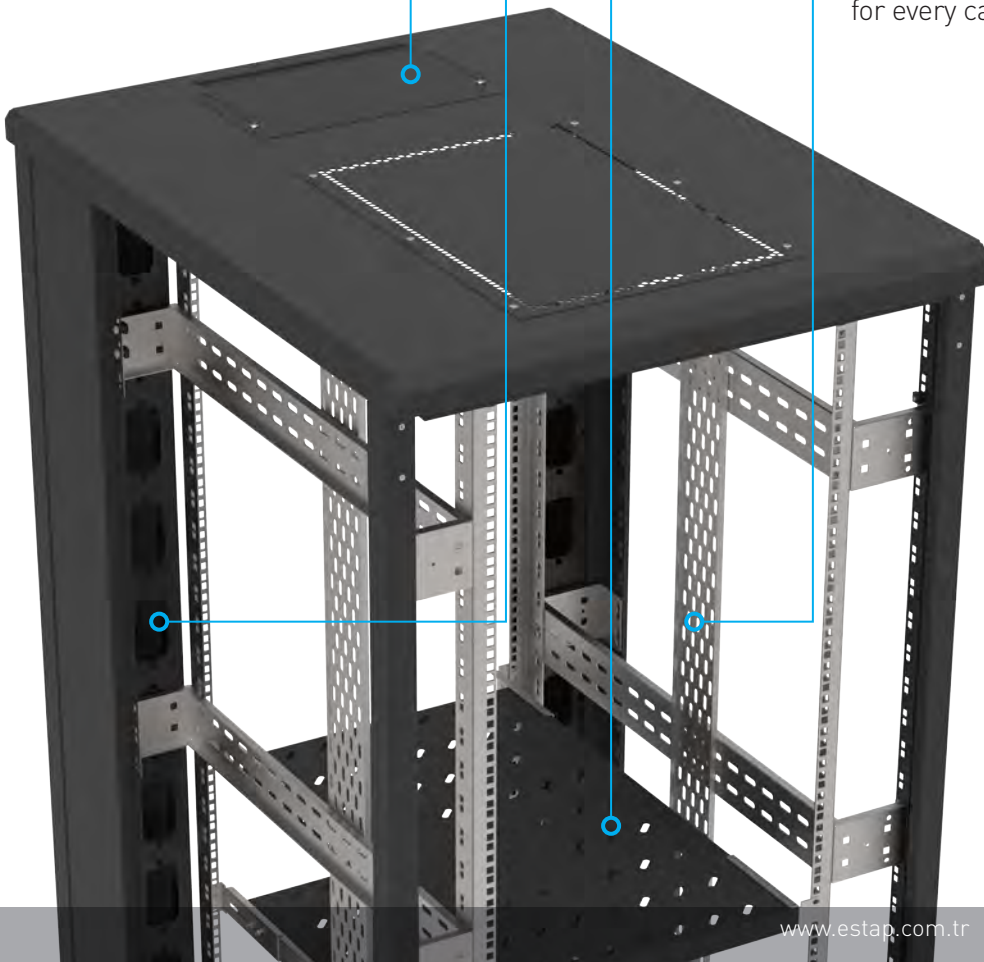

The image is for the width of 800 mm cabinet

ServerMax Accessories

CASTER AND LEVELLING FEET

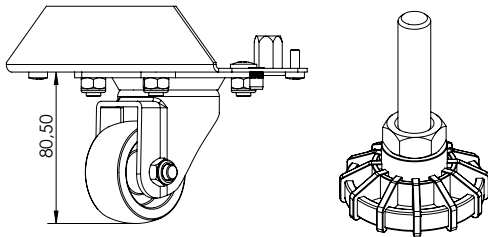

PRODUCT REFERENCE	DESCRIPTION
CST	Castors, 2 pcs. front are lockable
M11PNY02	Levelling feet (1 set= 4 pcs.)
M11PNY35	Heavy duty type levelling feet, metal, inner filled with rubber (1set= 4ea), height=35mm., adjustable
M11PNY99	Heavy duty type levelling feet, metal, inner filled with rubber (1set= 4ea), height=90mm., adjustable

PLINTH

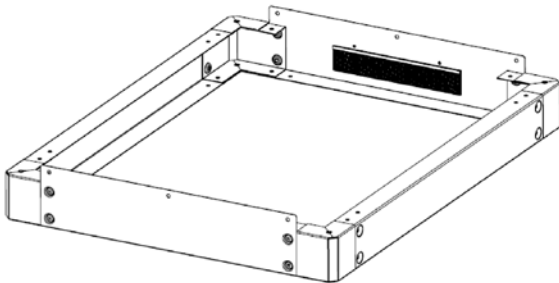
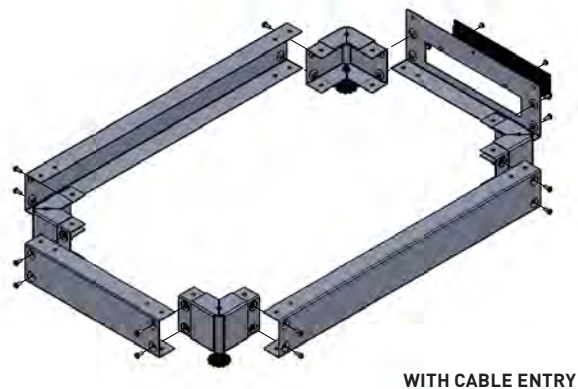

PRODUCT REFERENCE	DESCRIPTION
M11PNT610SRV_01M50	Plinth width= 600mm. depth= 1000mm. with balancing bars
M11PNT810SRV_01M50	Plinth width= 800mm. depth= 1000mm. with balancing bars

HEAVY DUTY TYPE SHELF

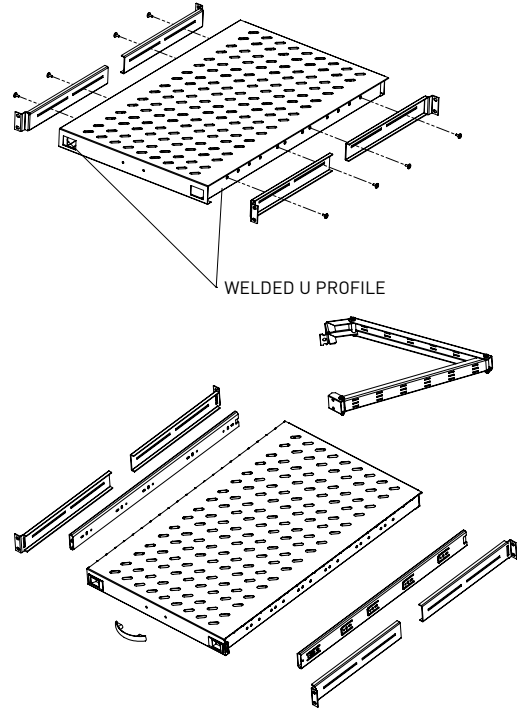

PRODUCT REFERENCE	DESCRIPTION	HxWxD (mm)
M55SR720_01M50	19", heavy duty fixed shelf, adjustable in depth	50x483x720
M55HR720_01M50	19", heavy duty sliding shelf, adjustable in depth, vented, complete with rear cable management system	50x483x720

19" KEYBOARD DRAWER

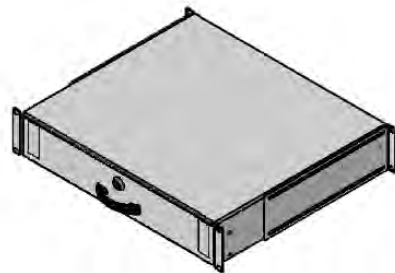

PRODUCT REFERENCE	DESCRIPTION	DIMENSIONS WxHxD (mm)
M44CEK2U_01M50	2U 19" drawer, lockable suitable up to depth=800mm. Cabinets, for D=1000 mm cabinet usage extra brackets available in package, sheet steel material and load carrying capacity is 25 kg.	483x88x400
M44CEK3U_01M50	3U 19" drawer, lockable suitable up to depth=800mm. Cabinets, for D=1000 mm cabinet usage extra brackets available in package, sheet steel material and load carrying capacity is 25 kg.	483x133x400

Note: Color code "M50" is RAL 9005 black, "M2" RAL 7035 light grey option is available

FIXED AND SLIDING SHELVES

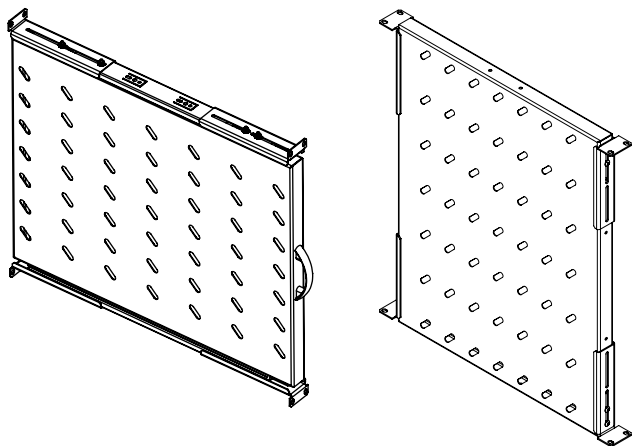

PRODUCT REFERENCE	DESCRIPTION
SHLFIX100M50	D= 1000 mm fixed shelf module with slots, load capacity 50 kg., Ral9005, depth of the shelf D= 696 mm, 4-points fixed. Only suitable for 1000 mm depth cabinets.
SHLSLD100M50	D= 1000 mm sliding shelf module with slots, load capacity 30 kg., Ral9005, depth of the shelf D= 696 mm, 4-points fixed. Only suitable for 1000 mm depth cabinets.

BLANK PANELS

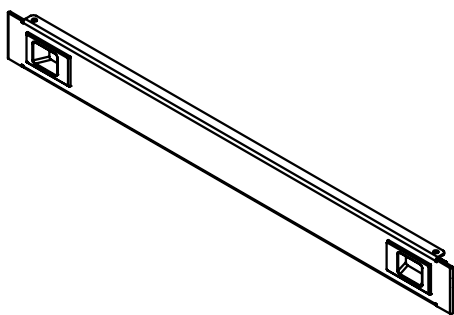

PRODUCT REFERENCE	DESCRIPTION	DIMENSIONS WxHxD (mm)
E44BPN01_0150M	1U 19" Blank panel	483x44x12
E44BPN02_0150M	2U 19" Blank panel	483x88x12
E44BPN03_0150M	3U 19" Blank panel	483x133x12
E44BPN04_0150M	4U 19" Blank panel	483x177x12
E44BPN05_0150M	5U 19" Blank panel	483x222x12
E44BPN06_0150M	6U 19" Blank panel	483x266x12
P44BPN06_01M50	6U 19" Modular plastic blank panel (ABS)	483x266x12

Note: Color code "M50" is RAL 9005 black, "M2" RAL 7035 light grey option is available

FAN MODULE

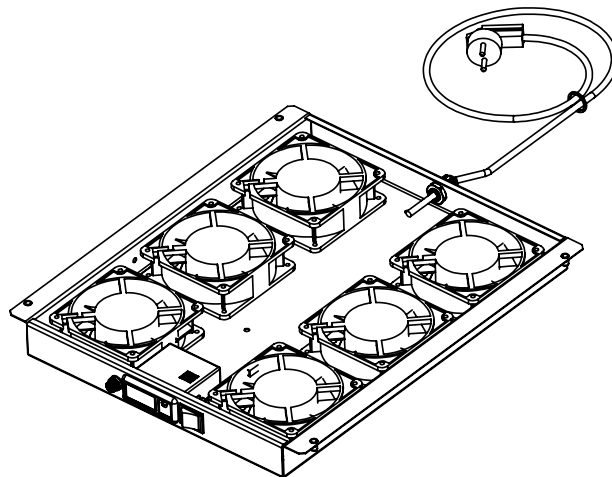

PRODUCT REFERENCE	DESCRIPTION
FAN4DT4F01_M50	Fan module, 4 fan + digital thermostat, 2P+E plug, schuko std., 4 pre-cut hole
FAN4DT4F02_M50	Fan module, 4 fan + digital thermostat, 2P+E plug, UK std., 4 pre-cut hole
FAN4O04F01_M50	Fan module, 4 fan + On/Off, 2P+E plug, schuko std., 4 pre-cut hole
FAN4O04F02_M50	Fan module, 4 fan + On/Off, 2P+E plug, UK std., 4 pre-cut hole
FAN4AT4F01_M50	Fan module, 4 fan + analog thermostat, 2P+E plug, schuko std., 4 pre-cut hole
FAN4AT4F02_M50	Fan module, 4 fan + analog thermostat, 2P+E plug, UK std., 4 pre-cut hole
FAN6DT6F01_M50	Fan module, 6 fan + digital thermostat, 2P+E plug, schuko std., 6 pre-cut hole
FAN6DT6F02_M50	Fan module, 6 fan + digital thermostat, 2P+E plug, UK std., 6 pre-cut hole
FAN6O06F01_M50	Fan module, 6 fan + On/Off, 2P+E plug, schuko std., 6 pre-cut hole
FAN6O06F02_M50	Fan module, 6 fan + On/Off, 2P+E plug, UK std., 6 pre-cut hole
FAN6AT6F01_M50	Fan module, 6 fan + analog thermostat, 2P+E plug, schuko std., 6 pre-cut hole
FAN6AT6F02_M50	Fan module, 6 fan + analog thermostat, 2P+E plug, UK std., 6 pre-cut hole

ServerMax Accessories

HORIZONTAL CABLE MANAGER

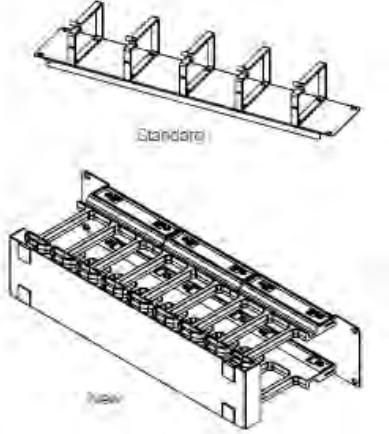

PRODUCT REFERENCE	DESCRIPTION	DIMENSIONS WxHxD (mm)
E440RG1U_01M50	1U 19" cable management panels with 5 metal rings	483x44x80
E440RG1UPLST_01M50	1U 19" cable management panels with 4 plastic rings	483x44x80
E440RG1UN_01M50	1U 19" cable management panel, channel type and with removable cover	483x44x71
E440RG2F_01M50	1U 19" cable management panels with front patch cord access holes, L shaped, rear tray for cable support	483x44x124
E440RG2F_01M50BN	1U 19" cable management panels with front patch cord access holes, basic blank panel shaped	483x44x10
E440RG2U_01M50	2U 19" cable management panels with 5 rings	483x88x76
E440RG1F_01M50	1/2U 19" cable management panels with front patch cord access holes	483x22x100
E440RG2UFT_01M50	2U 19", Cable Management Panels with 5 Metal Rings - Finger Type	483x88x166

GROUNDING KIT

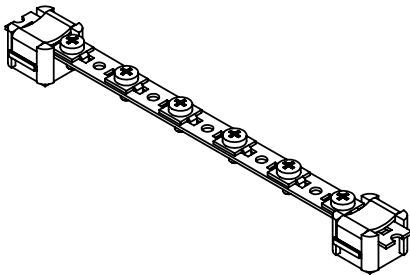

PRODUCT REFERENCE	DESCRIPTION
M44PEB01	Grounding kit, 6 each earthing leads + copper busbar
M44PEB19_01	Grounding kit, 13 each earthing leads + copper busbar

VERTICAL CABLE MANAGER

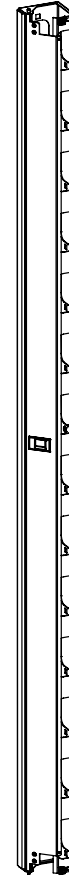

PRODUCT REFERENCE	DESCRIPTION
M440RG26_03M50	26U Vertical Cable Organizer
M440RG36_03M50	36U Vertical Cable Organizer
M440RG42_03M50	42U Vertical Cable Organizer
M440RG47_03M50	47U Vertical Cable Organizer

LED LIGHT

PRODUCT REFERENCE	DESCRIPTION	HxWxD (mm)
MAYDNLED-IRM	LED LIGHT	10X300X30

Note: Color code "M50" is RAL 9005 black, "M2" RAL 7035 light grey option is available

CABLE TRAY

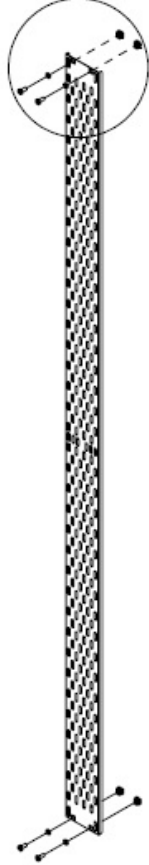

PRODUCT REFERENCE	DESCRIPTION
CT2610	Cable Tray, 26U, w= 100 mm
CT3610	Cable Tray, 36U, w= 100 mm
CT4210	Cable Tray, 42U, w= 100 mm
CT4710	Cable Tray, 47U, w= 100 mm

FIXINGS

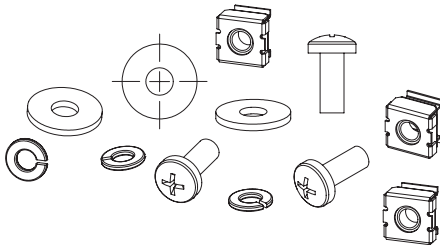

PRODUCT REFERENCE	DESCRIPTION
KFS6X15_20	M6 caged nut, screw, washer (1set=20ea)
KFS6X15_50	M6 caged nut, screw, washer (1set=50ea)

Note: Color code "M50" is RAL 9005 black, "M2" RAL 7035 light grey option is available

FLOOR FIXING KIT

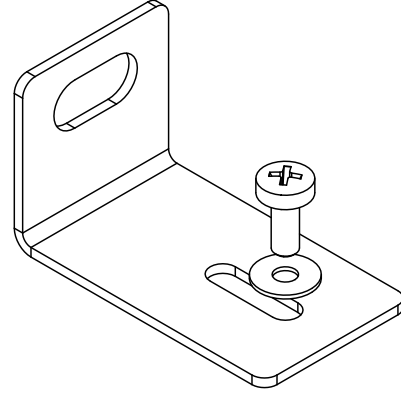

PRODUCT REFERENCE	DESCRIPTION
M44DPR03X	Floor fixing kit for W=600mm
M44DPR04X	Floor fixing kit W= 800 mm

BAYING KIT

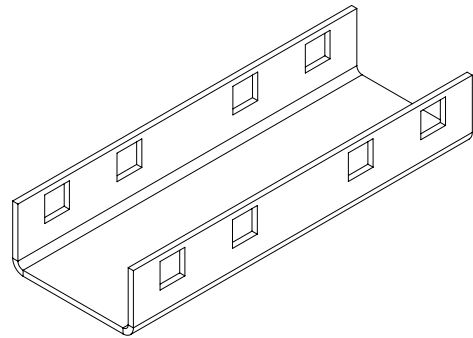

PRODUCT REFERENCE	DESCRIPTION
M44BLG01	Baying kit for all type of cabinets

ServerMax

TECHNICAL CHARACTERICS

FRONT DOOR

Single opening, monoblock, welded, curved, 63% perforated

FRONT DOOR CONSTRUCTION

Monoblock curved, welded construction

FRONT DOOR LOCK

Handle type, 3 point locking

HINGE SYSTEM

Spring loaded

DOOR OPENING ANGLE AND SWAPPING

215 degree

SIDE PANEL

Solid metal, 1 mm. Left and right (2ea.)

CONSTRUCTION

Lockable, removable c/with slam latches and lock

LOCK

Barrel type lock unit, single point + slam latch (2ea)

REAR DOOR

Solid metal, 1 mm

REAR DOOR CONSTRUCTION

Double door opening, 63% perforated, lockable, removable

REAR DOOR LOCK

Handled type lock unit, 3 point

HINGE SYSTEM

Spring loaded

DOOR OPENING ANGLE AND SWAPPING

215 degree

FRAMEWORK

Top and bottom base units

Solid Metal 2 mm

Top and bottom base units construction

Completely welded corner socket system

UPRIGHTS

Solid metal, 2 mm

UPRIGHTS CONSTRUCTION

Tightly fixed into top and bottom base units

3 times folded 3 x 2 = 6 folds

SIDE PANEL DIVIDER PROFILE

Solid metal 2 mm

SIDE PANEL CONSTRUCTION

Tightly fixed into top and bottom base units

4 times folded x 2 = 8 folds

INTERIOR PARTS

19" MOUNTING ANGLES

Solid metal, 2 mm

1 times folded for an L profile system

U marking available

2 ea. at rear, 2 ea. at front

Pre-configured as 19"

Zinc plated, passivated, 8-12 micron

Adjustable in depth

OMEGA TYPE SUPPORT RAILS IN DEPTH

Solid metal, 1,5 mm

3 times folded for W=600 mm cabinets

Omega type folded for W=780 mm cabinets

3 ea. at left, 3 ea. at right 26U and 36U

4 ea. at left, 4 ea. at right 42U and 47U

PURCHASED PRODUCT CERTIFICATION

SHEET STEEL

EN 10346: 20015 DX51D+Z, EN 10130: 2006 DC01

ELECTROSTATIC POWDER COATING

ISO6860, ISO2409, ISO1520, ISO2815, ISO6272, ISO7253, ISO6270-1, ISO2812

ISO 9001, RoHS

GLASS

TS EN 12150-1, TS EN 1863-1

LOCK

IEC 62474, REACH, RoHS

CASTORS

ISO 9001, TS EN 12532, RoHS

FAN

IEC 60335-2-80:2002, IEC 60335-1:2010

TESTS AND COMPLIED STANDARDS

TESTS AND COMPLIED STANDARDS

- 1) ISO 9001:2015 Quality Management System
- 2) ISO 14001:2015 Environmental Management System
- 3) ISO 27001:2013 Information Security Management System
- 4) ISO 45001:2018 Occupational Health and Safety Management System
- 5) 19" device mounting uprights IEC 297-1
- 6) EN 61587-1 Mechanical structures for electronic equipment.
- 7) All cabinet sizes complies with IEC 297-2.

RESISTANCE TO ENVIRONMENTAL CONDITIONS AND CORROSION;

STABILITY, MECHANICAL SAFETY, RESISTANCE TO STATIC, DYNAMIC AND MECHANICAL LOADS;

RESISTANCE TO VIBRATION, MECHANICAL SHOCK AND IMPACT;

DEGREES OF MECHANICAL PROTECTION PROVIDED BY THE ENCLOSURE (IP20);

ELECTRICAL GROUNDING CONTINUITY;

FIRE AND FLAME RESISTANCE;

Have been tested according to the standard " EN 61587-1" with the normative standards: IEC 60917, IEC 60297, IEC 60068-1, IEC 60068-2, IEC 60695-11-10, IEC 60950-1, contained and certified by the notified organizations::

TSE CERTIFICATE NO

003788-TSE-08/02

EAC CERTIFICATE NO

0443637, 0776963, 0345864, 0401678, 0776653

CORROSION

ISO 9227 Standard complied by the test report METALTEK AB-0547-T / 0157-1

TRANSPORT

ETS 300 019-1-2 Class 2.3 Comply with internal testing

STORAGE

ETS 300 019-1-1 Class 1.2 Comply with internal testing

SURFACE FINISH

Electrostatic powder coated c/with surface treatment , 80 +/- 5 micron paint thickness



CloudMax

Intro

19" free-standing server cabinet series for mission critical operations such as data storage, server housing, infrastructural cabling and has also solutions for hot/cold corridor data center architecture.



GENERAL CHARACTERISTICS

- IP20 protection level for cooling performance
- 63% and 80% perforated front/rear doors for best air circulation
- Heavy duty structure, 1500kg load carrying capacity
- Wide Range of cabinet sizes and accessories
- Dimensions:
26/32/36/39/42/45/47U 600 or 800x1000/1100/1200 mm
- Ample variety of accessories
- Maximum inner space for servers
- Professional cable management on top, bottom and inner of cabinet
- Compatibility with all vendors' servers
- High technical performance; grounding continuity
- Aesthetic and professional view
- Overhead cable trays separate electrical and data cables



New Level Of Powerful Standards

Cloudmax 19" cabinets have extra-ordinary durability and innovative flexibility.

- With special design of side frames, you can move the 19" mounting rails while equipments loaded
- Simply the raceway for cables are created by fixing cable rings on all profiles in front and rear part of the cabinets
- Easy movable 19" profiles to front/rear
- Standard tilt protection bars
- Floor fixing, plinth, baying kit options
- Reliable fan module options: Equipped with up to 6 x Fans, On/Off button, fuse, analog or digital thermostat & wired mesh fences
- Multiple brushed cable entries on top and the bottom of the cabinet
- Standard colors:
RAL 9005 Black & RAL 7035 Light Grey
- Easy assembling flat pack option provides ease whilst reducing volume 50% for transportation
- Side panels are lockable & removable sheet steel panels to complete the flexibility and 4-way easy access



CloudMax

DIMENSIONS

W:600 MM CABINETS, WITH SINGLE FRONT DOOR-DOUBLE REAR DOOR, SIDE PANELS AND TILTING BAR

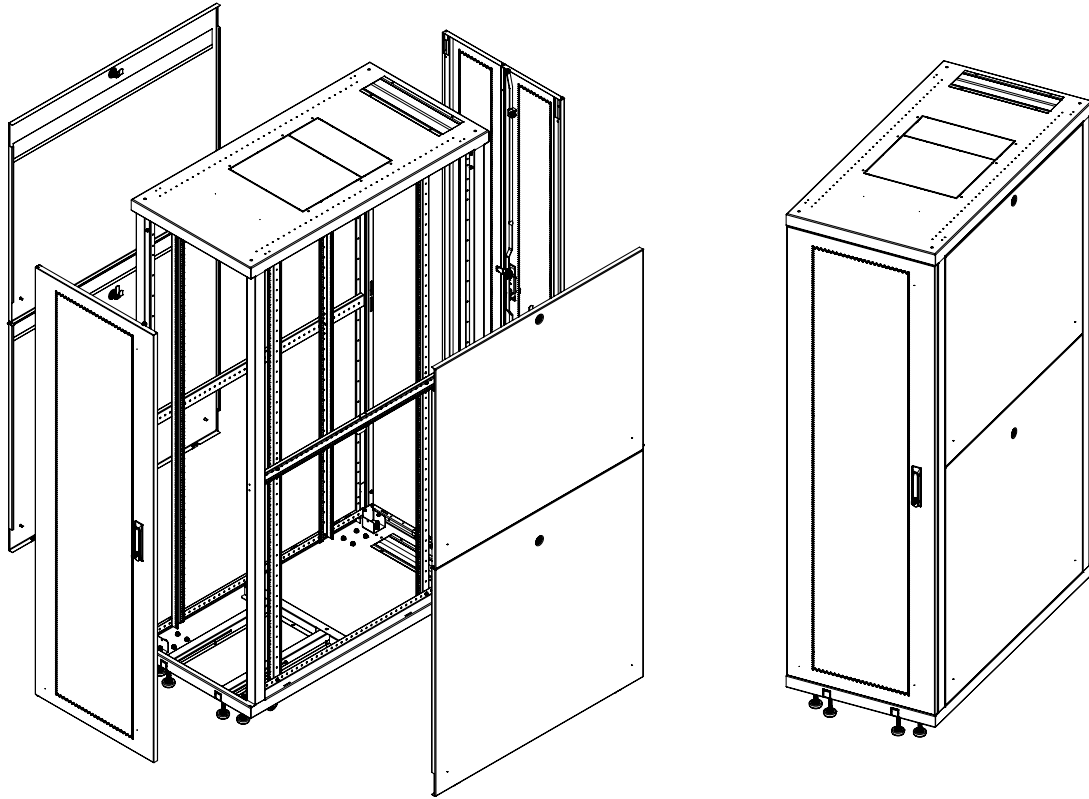

PRODUCT REFERENCE	U SIZE	WIDTH: OVERALL (MM)	DEPTH: OVERALL (MM)	DEPTH: MAX MOUNTING PROFILE (MM)	HEIGHT: VERTICAL MOUNTING PROFILE (MM)	HEIGHT: WITHOUT LEVELLING FEET (MM)	HEIGHT: WITH LEVELLING FEET MIN (MM)	HEIGHT: WITH CASTERS (MM)
CLD26U6010_M50_SVF63DVR63	26	600	1000	830	1156	1256	1341	1336
CLD32U6010_M50_SVF63DVR63	32	600	1000	830	1423	1523	1608	1603
CLD36U6010_M50_SVF63DVR63	36	600	1000	830	1601	1701	1786	1781
CLD39U6010_M50_SVF63DVR63	39	600	1000	830	1734	1834	1919	1914
CLD42U6010_M50_SVF63DVR63	42	600	1000	830	1867	1967	2052	2047
CLD47U6010_M50_SVF63DVR63	47	600	1000	830	2089	2189	2274	2269
CLD26U6012_M50_SVF63DVR63	26	600	1200	1030	1156	1256	1341	1336
CLD32U6012_M50_SVF63DVR63	32	600	1200	1030	1423	1523	1608	1603
CLD36U6012_M50_SVF63DVR63	36	600	1200	1030	1601	1701	1786	1781
CLD39U6012_M50_SVF63DVR63	39	600	1200	1030	1734	1834	1919	1914
CLD42U6012_M50_SVF63DVR63	42	600	1200	1030	1867	1967	2052	2047
CLD47U6012_M50_SVF63DVR63	47	600	1200	1030	2089	2189	2274	2269

Note: Color code "M50" is RAL 9005 black, "M2" RAL 7035 light grey option is available

DIMENSIONS

W: 600 MM CABINETS WITHOUT DOORS, SIDE PANELS AND TILTING BAR

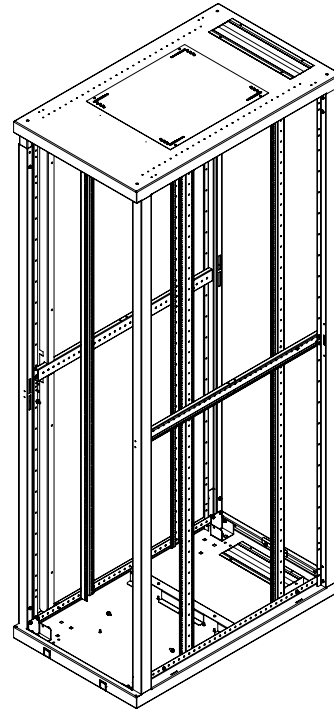
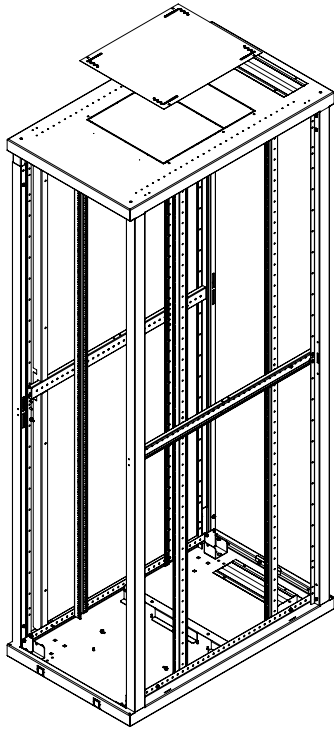

TABLE 1

PRODUCT REFERENCE MAIN CODE	DESCRIPTION
CLD26U6010_M50	26U 600 X1000 RAL 9005
CLD26U6011_M50	26U 600 X1100 RAL 9005
CLD26U6012_M50	26U 600 X1200 RAL 9005
CLD32U6010_M50	32U 600 X1000 RAL 9005
CLD32U6011_M50	32U 600 X1100 RAL 9005
CLD32U6012_M50	32U 600 X1200 RAL 9005
CLD36U6010_M50	36U 600 X1000 RAL 9005
CLD36U6011_M50	36U 600 X1100 RAL 9005
CLD36U6012_M50	36U 600 X1200 RAL 9005
CLD39U6010_M50	39U 600 X1000 RAL 9005
CLD39U6011_M50	39U 600 X1100 RAL 9005
CLD39U6012_M50	39U 600 X1200 RAL 9005

PRODUCT REFERENCE MAIN CODE	DESCRIPTION
CLD42U6010_M50	42U 600 X1000 RAL 9005
CLD42U6011_M50	42U 600 X1100 RAL 9005
CLD42U6012_M50	42U 600 X1200 RAL 9005
CLD45U6010_M50	45U 600 X1000 RAL 9005
CLD45U6011_M50	45U 600 X1100 RAL 9005
CLD45U6012_M50	45U 600 X1200 RAL 9005
CLD47U6010_M50	47U 600 X1000 RAL 9005
CLD47U6011_M50	47U 600 X1100 RAL 9005
CLD47U6012_M50	47U 600 X1200 RAL 9005

Note: Color code "M50" is RAL 9005 black, "M2" RAL 7035 light grey option is available

CloudMax

DIMENSIONS

W:800 MM CABINETS, WITH SINGLE FRONT DOOR-DOUBLE REAR DOOR, SIDE PANELS AND TILTING BAR

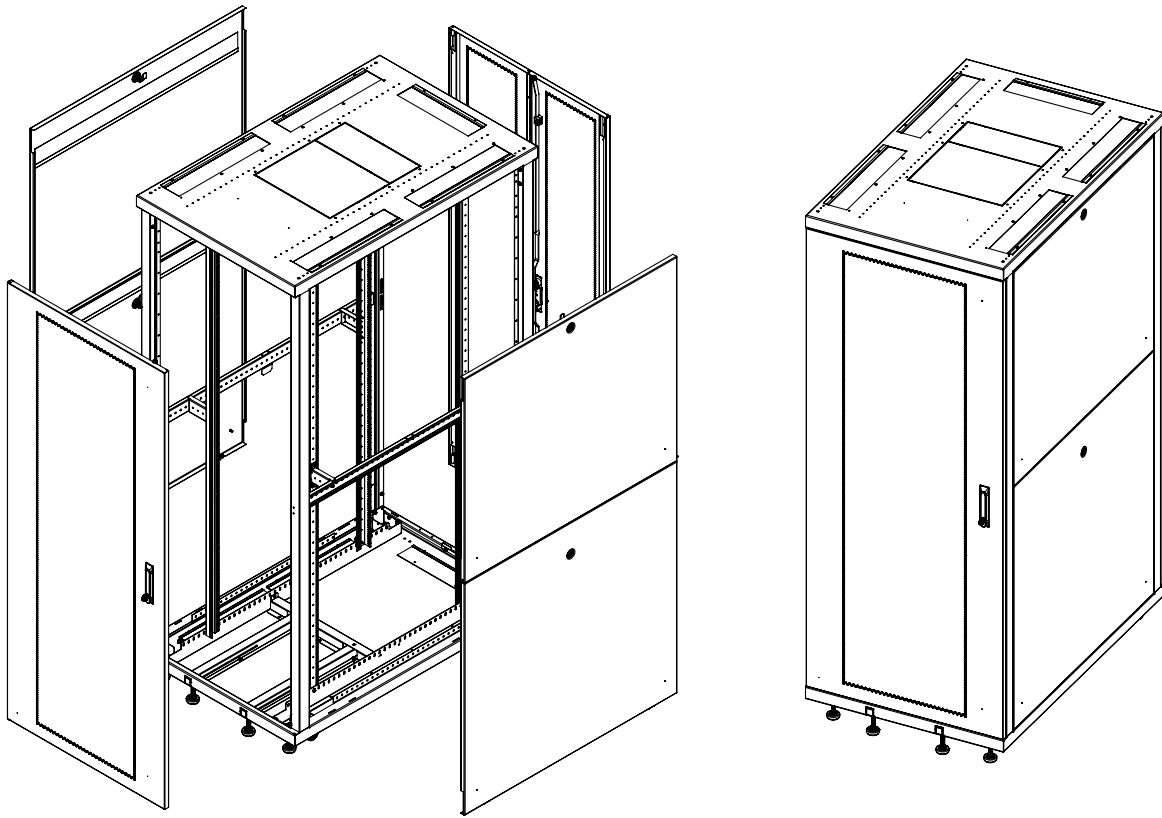

PRODUCT REFERENCE	U SIZE	WIDTH: OVERALL (MM)	DEPTH: OVERALL (MM)	DEPTH: MAX MOUNTING PROFILE (MM)	HEIGHT: VERTICAL MOUNTING PROFILE (MM)	HEIGHT: WITHOUT LEVELLING FEET (MM)	HEIGHT: WITH LEVELLING FEET MIN (MM)	HEIGHT: WITH CASTERS (MM)
CLD36U8010_M50_SVF63DVR63	36	800	1000	830	1601	1701	1786	1781
CLD39U8010_M50_SVF63DVR63	39	800	1000	830	1734	1834	1919	1914
CLD42U8010_M50_SVF63DVR63	42	800	1000	830	1867	1967	2052	2047
CLD47U8010_M50_SVF63DVR63	47	800	1000	830	2089	2189	2274	2269
CLD36U8012_M50_SVF63DVR63	36	800	1200	1030	1601	1701	1786	1781
CLD39U8012_M50_SVF63DVR63	39	800	1200	1030	1734	1834	1919	1914
CLD42U8012_M50_SVF63DVR63	42	800	1200	1030	1867	1967	2052	2047
CLD47U8012_M50_SVF63DVR63	47	800	1200	1030	2089	2189	2274	2269

Note: Color code "M50" is RAL 9005 black, "M2" RAL 7035 light grey option is available

DIMENSIONS

W: 800 MM CABINETS WITHOUT DOORS, SIDE PANELS AND TILTING BAR.

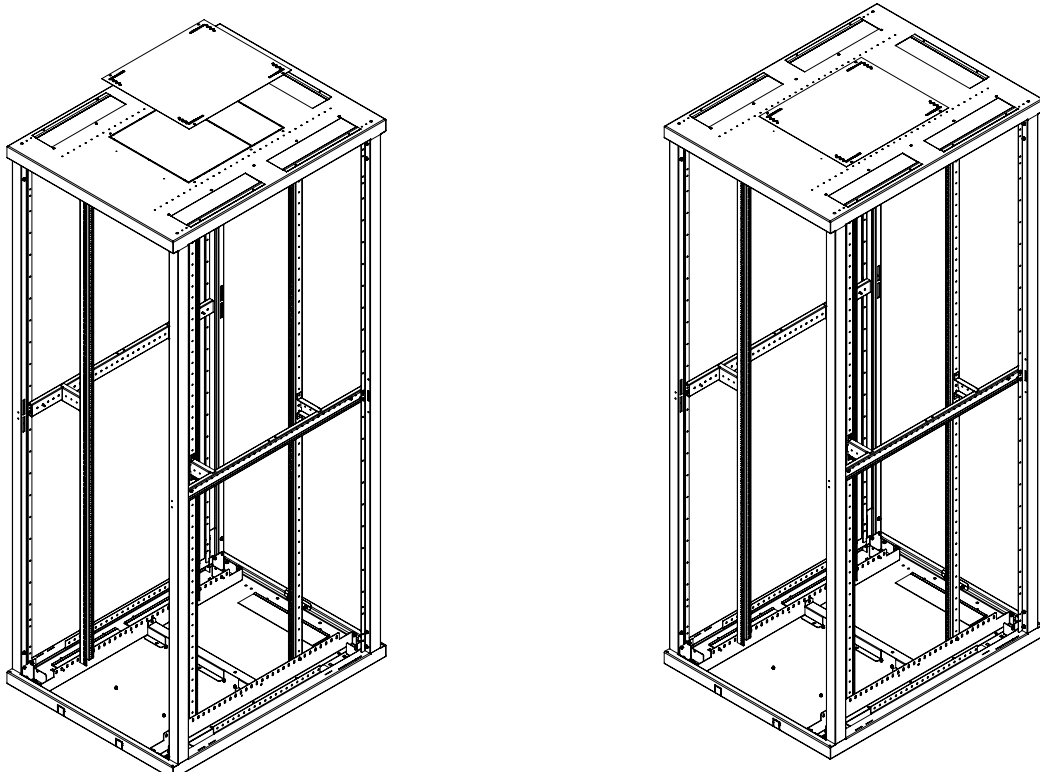

TABLE 2

PRODUCT REFERENCE MAIN CODE	DESCRIPTION
CLD36U8010_M50	36U 800 X1000 RAL 9005
CLD36U8011_M50	36U 800 X1100 RAL 9005
CLD36U8012_M50	36U 800 X1200 RAL 9005
CLD39U8010_M50	39U 800 X1000 RAL 9005
CLD39U8011_M50	39U 800 X1100 RAL 9005
CLD39U8012_M50	39U 800 X1200 RAL 9005
CLD42U8010_M50	42U 800 X1000 RAL 9005
CLD42U8011_M50	42U 800 X1100 RAL 9005
CLD42U8012_M50	42U 800 X1200 RAL 9005

PRODUCT REFERENCE MAIN CODE	DESCRIPTION
CLD45U8010_M50	45U 800 X1000 RAL 9005
CLD45U8011_M50	45U 800 X1100 RAL 9005
CLD45U8012_M50	45U 800 X1200 RAL 9005
CLD47U8010_M50	47U 800 X1000 RAL 9005
CLD47U8011_M50	47U 800 X1100 RAL 9005
CLD47U8012_M50	47U 800 X1200 RAL 9005

Note: Color code "M50" is RAL 9005 black, "M2" RAL 7035 light grey option is available

CloudMax

DOOR OPTIONS FOR TABLE 1 & TABLE 2

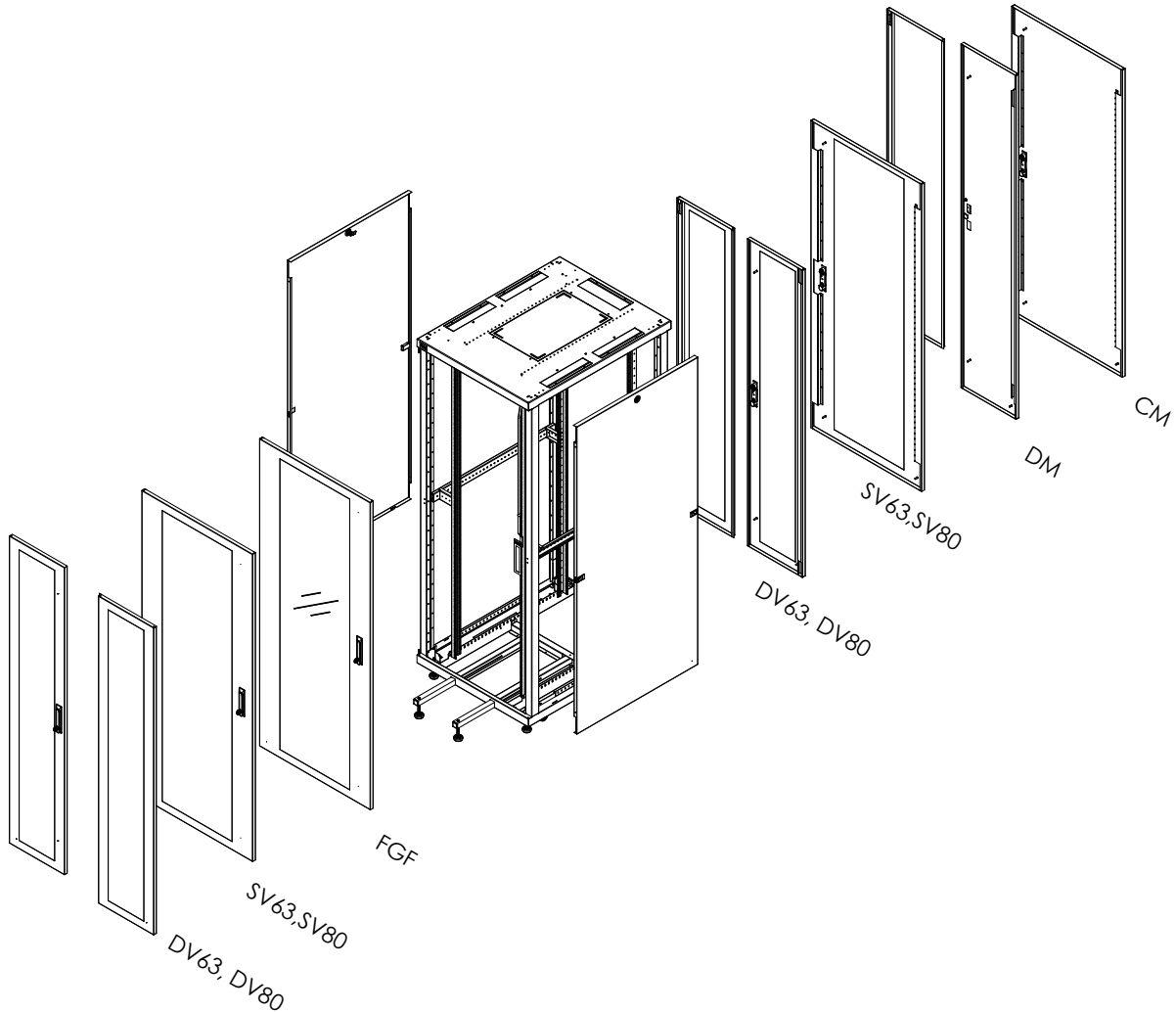

DOOR CODE	DESCRIPTION
FGF	Single, Full Frame Glass Front/Rear Door
SV63	Single Vented Front/Rear Door, 63% perforated
DV63	Double Vented Front/Rear Door, 63% perforated
SV80	Single Vented Front Door/Rear, 80% perforated
DV80	Double Vented Front/Rear Door, 80% perforated
CM	Single Solid Metal Front/Rear Door
DM	Double Solid Metal Front/Rear Door

Note; All door codes can be used in the front or rear

Note: Color code "M50" is RAL 9005 black, "M2" RAL 7035 light grey option is available

DOOR OPTIONS FOR TABLE 1 & TABLE 2

TABLE 3

PRODUCT REFERENCE DOOR CODE	DOOR CODES SELECTION TABLE		
CLD26U600FGF_M50	CLD26U600SV63_M50	CLD26U600SV80_M50	
CLD32U600FGF_M50	CLD32U600SV63_M50	CLD32U600SV80_M50	
CLD36U600FGF_M50	CLD36U600SV63_M50	CLD36U600SV80_M50	
CLD39U600FGF_M50	CLD39U600SV63_M50	CLD39U600SV80_M50	
CLD42U600FGF_M50	CLD42U600SV63_M50	CLD42U600SV80_M50	
CLD45U600FGF_M50	CLD45U600SV63_M50	CLD45U600SV80_M50	
CLD47U600FGF_M50	CLD47U600SV63_M50	CLD47U600SV80_M50	
CLD26U600DV63_M50	CLD26U600DV80_M50	CLD26U600CM_M50	CLD26U600DM_M50
CLD32U600DV63_M50	CLD32U600DV80_M50	CLD32U600CM_M50	CLD32U600DM_M50
CLD36U600DV63_M50	CLD36U600DV80_M50	CLD36U600CM_M50	CLD36U600DM_M50
CLD39U600DV63_M50	CLD39U600DV80_M50	CLD39U600CM_M50	CLD39U600DM_M50
CLD42U600DV63_M50	CLD42U600DV80_M50	CLD42U600CM_M50	CLD42U600DM_M50
CLD45U600DV63_M50	CLD45U600DV80_M50	CLD45U600CM_M50	CLD45U600DM_M50
CLD47U600DV63_M50	CLD47U600DV80_M50	CLD47U600CM_M50	CLD47U600DM_M50

Table 3 for W=600 mm, please use these references with the cabinets in Table 1.

TABLE 3

PRODUCT REFERENCE DOOR CODE	DOOR CODES SELECTION TABLE		
CLD36U800FGF_M50	CLD36U800SV63_M50	CLD36U800SV80_M50	
CLD39U800FGF_M50	CLD39U800SV63_M50	CLD39U800SV80_M50	
CLD42U800FGF_M50	CLD42U800SV63_M50	CLD42U800SV80_M50	
CLD45U800FGF_M50	CLD45U800SV63_M50	CLD45U800SV80_M50	
CLD47U800FGF_M50	CLD47U800SV63_M50	CLD47U800SV80_M50	
CLD36U800DV63_M50	CLD36U800DV80_M50	CLD36U800CM_M50	CLD36U800DM_M50
CLD39U800DV63_M50	CLD39U800DV80_M50	CLD39U800CM_M50	CLD39U800DM_M50
CLD42U800DV63_M50	CLD42U800DV80_M50	CLD42U800CM_M50	CLD42U800DM_M50
CLD45U800DV63_M50	CLD45U800DV80_M50	CLD45U800CM_M50	CLD45U800DM_M50
CLD47U800DV63_M50	CLD47U800DV80_M50	CLD47U800CM_M50	CLD47U800DM_M50

Table 3 for W=800 mm, please use these references with the cabinets in Table 2.

Note 1: All door codes can be used in the front or rear

Note 2: Color code "M50" is RAL 9005 black, "M2" RAL 7035 light grey option is available

CloudMax

SIDE PANEL FOR TABLE 1 & TABLE 2

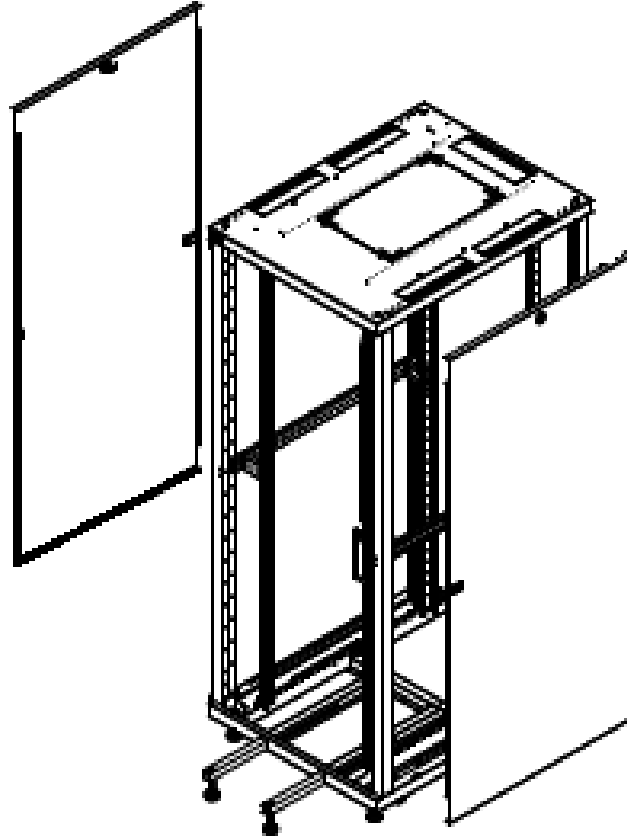
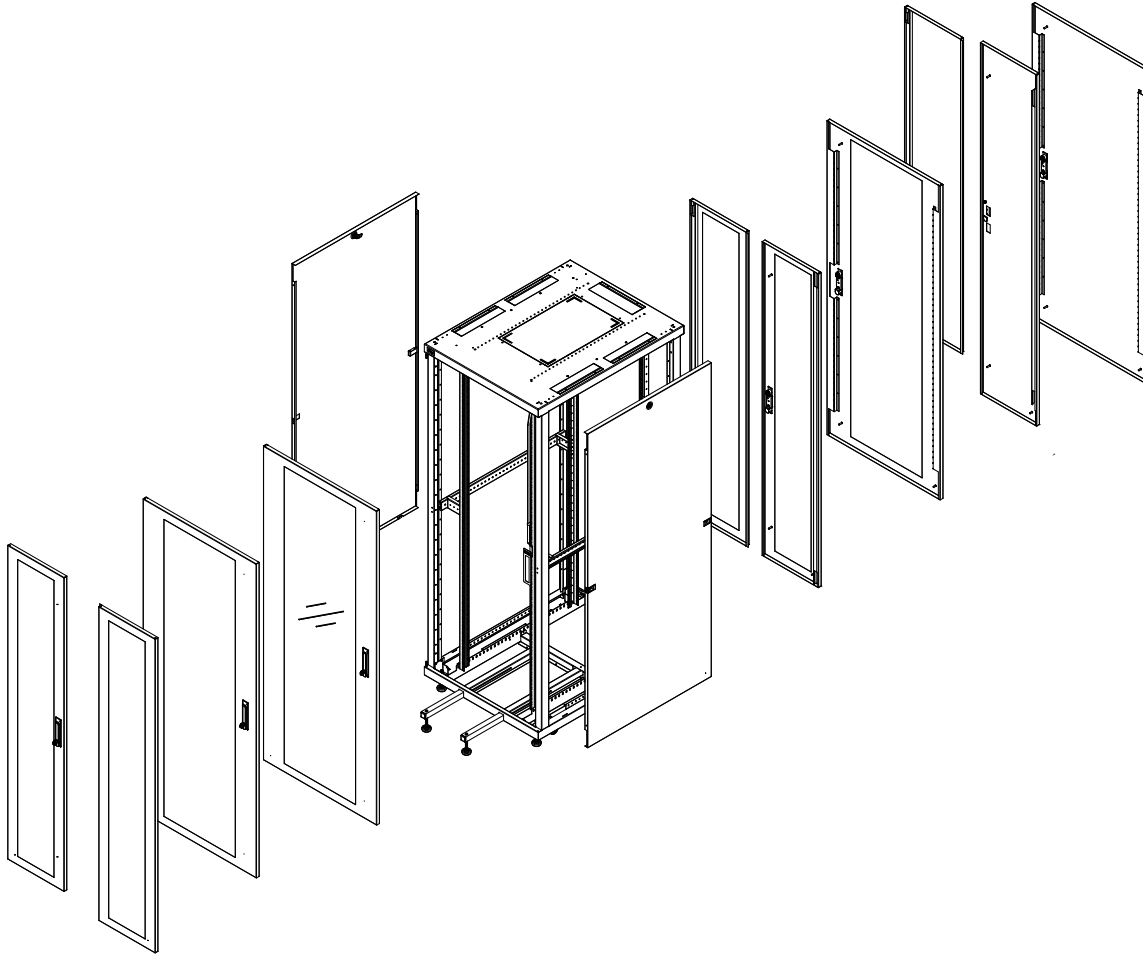

TABLE 4

PRODUCT REFERENCE SIDE PANEL CODES -HORIZONTAL-W=1000	PRODUCT REFERENCE SIDE PANEL CODES-HORIZONTAL-W=1100	PRODUCT REFERENCE SIDE PANEL CODES -HORIZONTAL-W=1200
CLDSPH26U100_M50	CLDSPH26U110_M50	CLDSPH26U120_M50
CLDSPH32U100_M50	CLDSPH32U110_M50	CLDSPH32U120_M50
CLDSPH36U100_M50	CLDSPH36U110_M50	CLDSPH36U120_M50
CLDSPH39U100_M50	CLDSPH39U110_M50	CLDSPH39U120_M50
CLDSPH42U100_M50	CLDSPH42U110_M50	CLDSPH42U120_M50
CLDSPH45U100_M50	CLDSPH45U110_M50	CLDSPH45U120_M50
CLDSPH47U100_M50	CLDSPH47U110_M50	CLDSPH47U120_M50

Note: Color code "M50" is RAL 9005 black, "M2" RAL 7035 light grey option is available

HOW TO CREATE A CABINET?



Please select main code (from table 1 and table 2) + door code(table 3)+side panel (table 4)

Ex1: If front/rear door codes are the same;

Main Code

Door Code

Side Panel Code

(1 x CLD42U8012_M50) + (2 x CLD42U800SV80_M50) + (1 x CLDSPH42U120_M50)

Ex2: If front/rear door codes are different;

Main Code

Door Code

Door Code

Side Panel Code

(1 x CLD47U6011_M50) + (1 x CLD47U600SV63_M50+1 x CLD47U600DV63_M50) + (1 x CLDSPH47U110_M50)

TECHNICAL DRAWINGS (mm)

TOP VIEWS

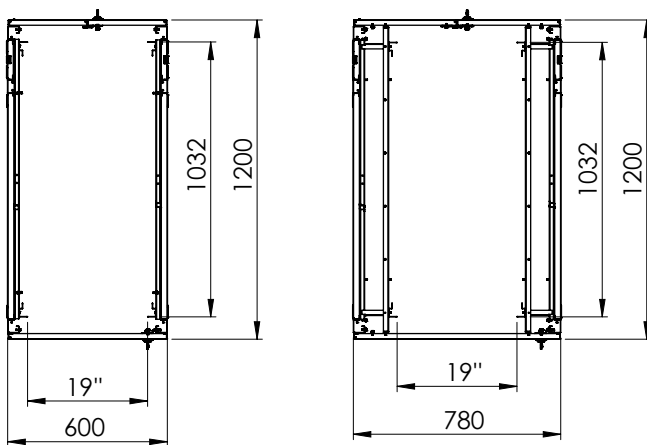
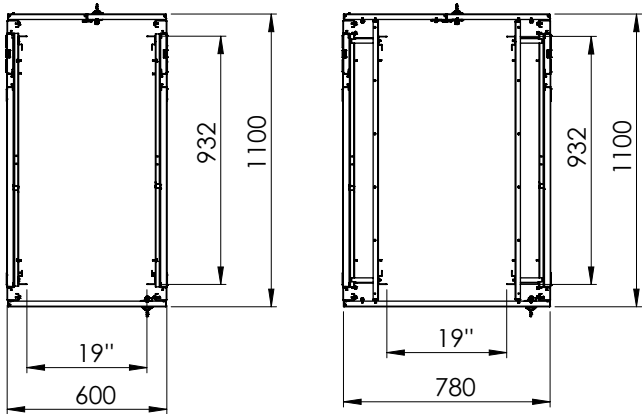
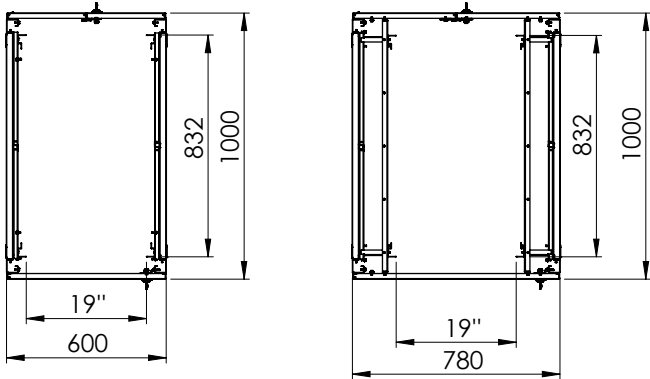

ROOF OPTIONS

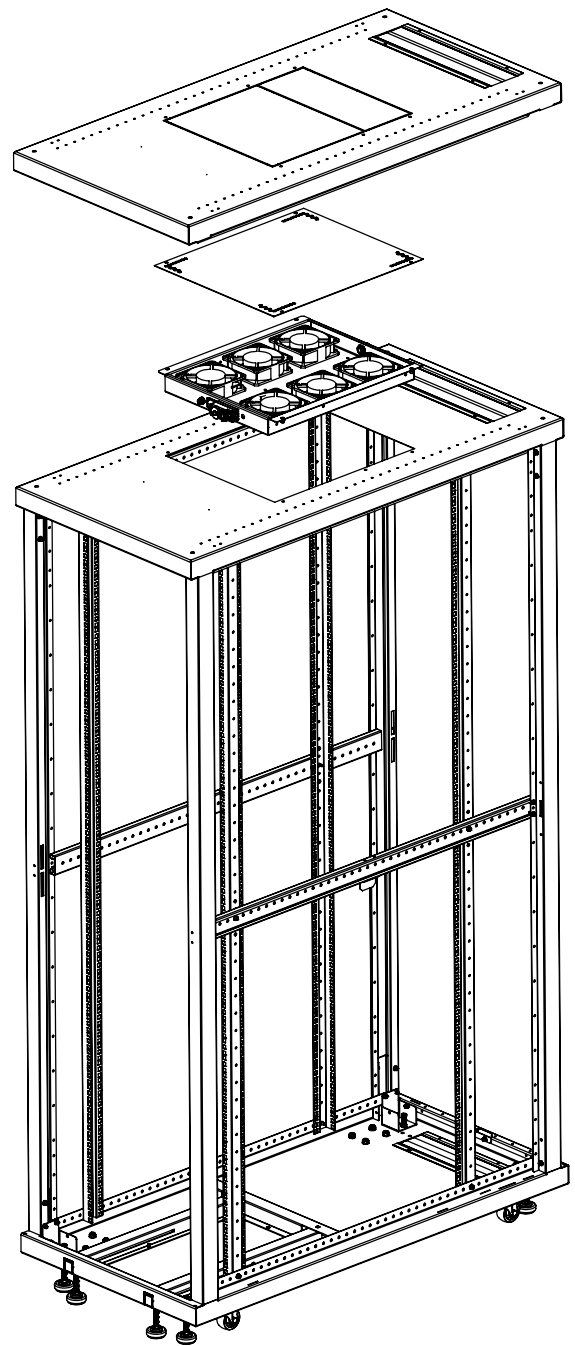

CloudMax High Density Cabling Cabinet

Professional cabinet solution for professional cabling.

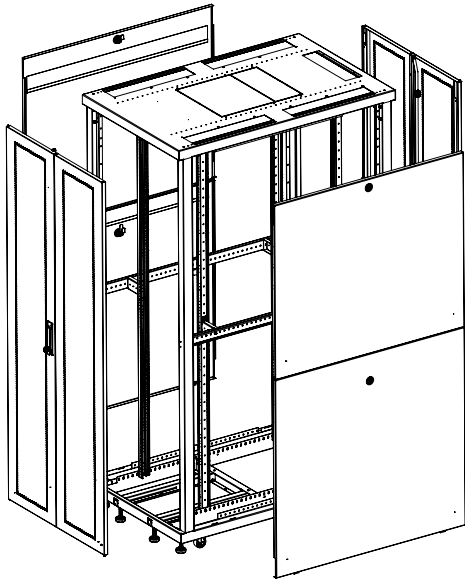

Exploded View

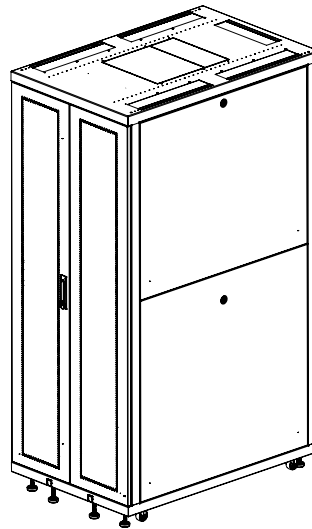

Iso View

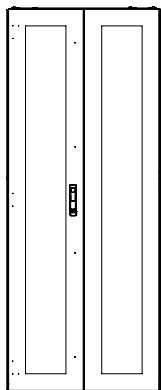

Front View

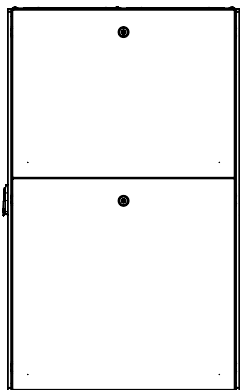

Side View

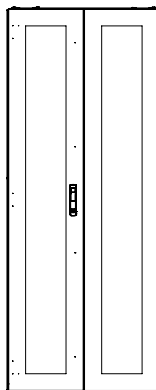

Back View

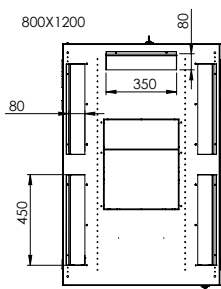

Top View

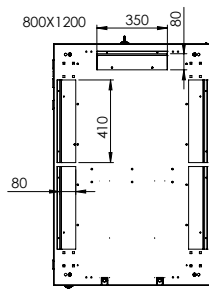

Bottom View

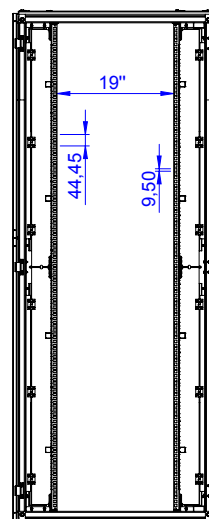

Front View

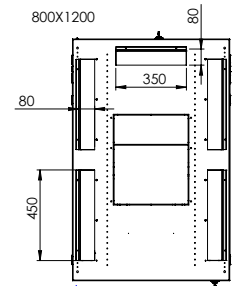

Top View

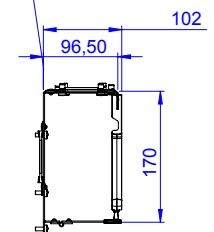

Organiser

19" FREE-STANDING RACK CABINETS

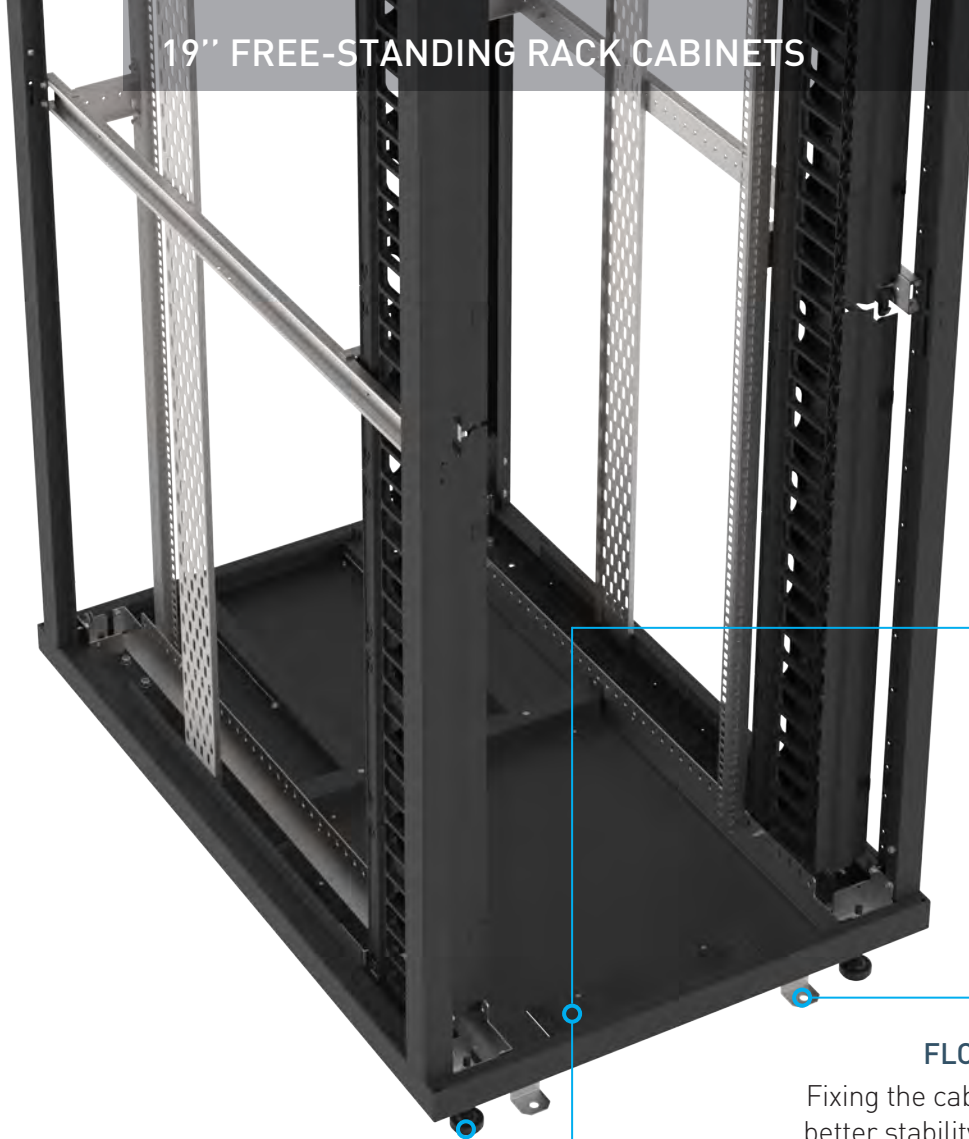

CASTERS AND LEVELLING FEET

Casters are rotational type and can move any direction
2 pcs. front are lockable
Load capacity per caster: Fixed: 50 kg, Moving: 25kg
Load capacity per levelling feet: 250 kg.
Levelling feet: Possible to adjust height of the feet from the floor.

FAN MODULE

4 or 6 pcs. of fan on a module, with ON/OFF, analog or digital thermostat functions. Complete inner wiring. 1U.

FLOOR FIXING KIT

Fixing the cabinet to floor for better stability. 4-point fixing.
Galvanized sheet metal

BRUSHED CABLE ENTRY

For the width 800 mm cabinets, there are 5 pieces; 4 pieces on both sides and 1 pcs. at the rear. The dimensions of the cable entries are different according to the depth of the cabinet.

For 1000 mm depth:

80 mm x 350 mm x4 ,80 mm x 350 mm x1

For 1100 mm depth:

80 mm x 400 mm x4 ,80 mm x 350 mm x1

For 1200 mm depth:

80 mm x 350 mm x1,80 mm x 450 mm x4

LED LIGHT

Effective and powerful lighting. Different dimensions. 19", 1U, with ON/OFF switch, automatic door with ON/OFF switch or LED with sensor.

GROUNDING CONTINUITY

Grounding cables for all metal components.
Cable connections with bolts and nuts for all doors.

CloudMax Accessories

CABLE TRAY

Options from 47U to 47U, w=100 mm and 200 mm. The galvanized coating must be perforated to provide length and cable installation along the height of the cabinet. Unified cable tray for every cabinet range.

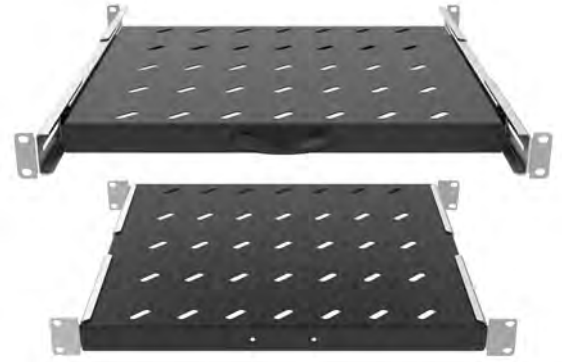

FIXED AND SLIDING SHELF

Fixing points at the sides of rear and front 19" uprights. Vented for air circulation, adjustable depth, sheet steel material. Available for all kind of cabinet depths like 1000mm and 1200mm.

BRUSHED CABLE ENTRY

For the width 800 mm cabinets, there are 5 pieces; 2 pieces on both sides. The dimensions of the cable entries are different according to the depth of the cabinet.

For 1000 mm depth:

80 mm x 300 mm x4, 80 mm x 350 mm x1

For 1100 mm depth:

80 mm x 400 mm (x4), 80 mm x 350 mm (x1)

For 1200 mm depth:

80 mm x 450 mm (x4), 80 mm x 350 mm (x1)

FINGER TYPE VERTICAL CABLE MANAGER

Options from 42U to 47U. Professional cabling with finger type structure makes the user's work easier. It provides more optimal using area in the cabinet.

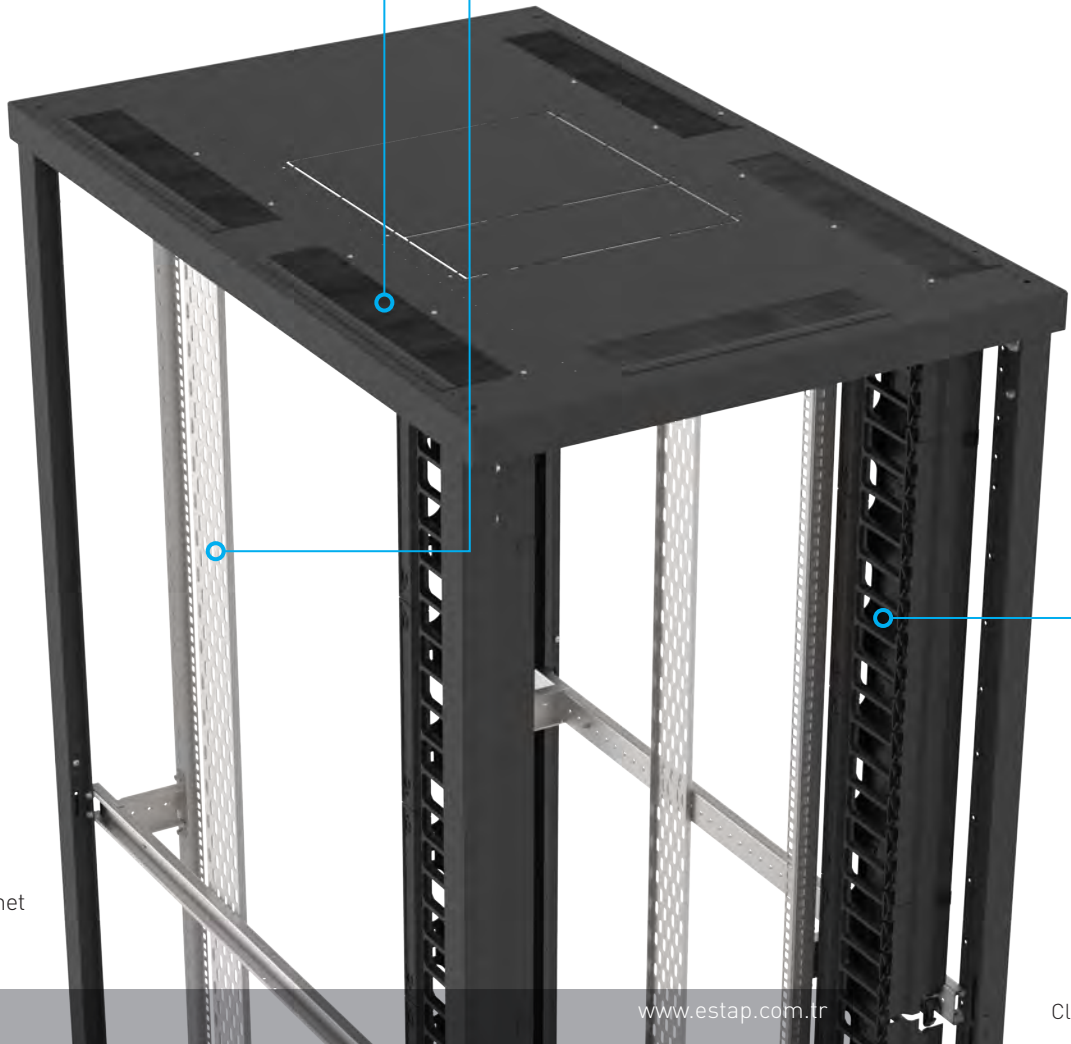

The image is for the width of 800 mm cabinet

CloudMax Accessories

PLINTH

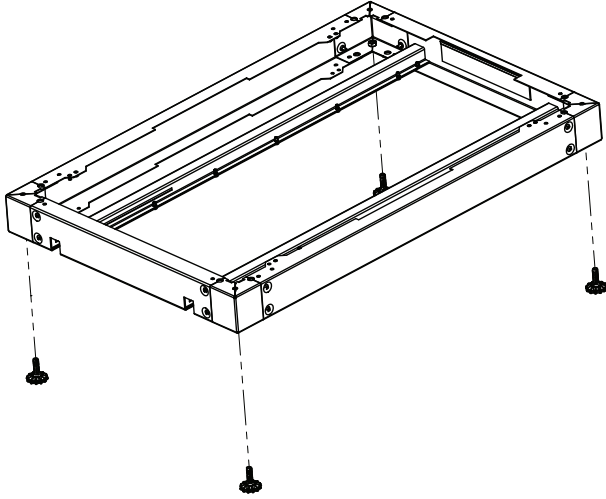

PRODUCT REFERENCE	DESCRIPTION	DIMENSIONS WxHxD (mm)
CLDPLT6010_01M50	Plinth for CLOUDMAX, w= 600 mm d= 1000 mm	600x1000
CLDPLT6011_01M50	Plinth for CLOUDMAX, w= 600 mm d= 1100 mm	600x1100
CLDPLT6012_01M50	Plinth for CLOUDMAX, w= 600 mm d= 1200 mm	600x1200
CLDPLT8010_01M50	Plinth for CLOUDMAX, w= 800 mm d= 1000 mm	800x1000
CLDPLT8011_01M50	Plinth for CLOUDMAX, w= 800 mm d= 1100 mm	800x1100
CLDPLT8012_01M50	Plinth for CLOUDMAX, w= 800 mm d= 1200 mm	800x1200

CASTER AND LEVELLING FEET

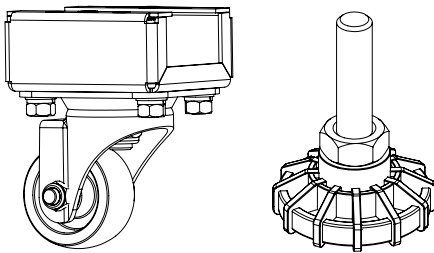

PRODUCT REFERENCE	DESCRIPTION
M44STB01	Casters, 2 pcs. front are lockable
TKRPNYM10X70	M10x70 Levelling feet

RAISED FLOOR SUPPORT KIT

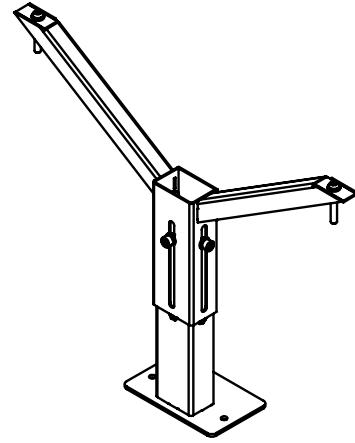

PRODUCT REFERENCE	DESCRIPTION
DCRFSK60_01M50	Raised floor support kit, for the cabinet w=600 mm, adjustable depth= 400-700 mm, 1 set 2 pcs
DCRFSK80_01M50	Raised floor support kit, for the cabinet w=800 mm, adjustable depth= 400-700 mm, 1 set 2 pcs

TILTING BAR

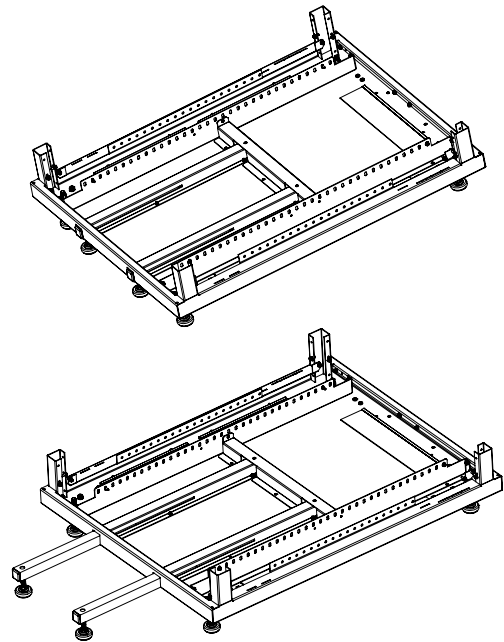

PRODUCT REFERENCE	DESCRIPTION
CLDTB_M50	CLOUDMAX TILTING BAR

Note: Color code "M50" is RAL 9005 black, "M2" RAL 7035 light grey option is available

FLOOR FIXING KIT

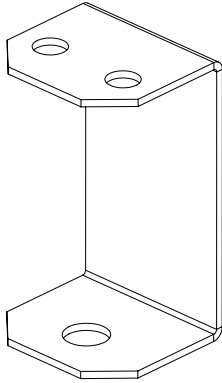

PRODUCT REFERENCE	DESCRIPTION
CLDFSM80_01M50	CLOUDMAX 800mm corridor floor fixing kit
CLDFSM60_01M50	CLOUDMAX 600mm corridor floor fixing kit
CLDFSM80_02M50	CLOUDMAX 800mm floor fixing kit
CLDFSM60_02M50	CLOUDMAX 600mm floor fixing kit

CABLE MANAGEMENT RINGS

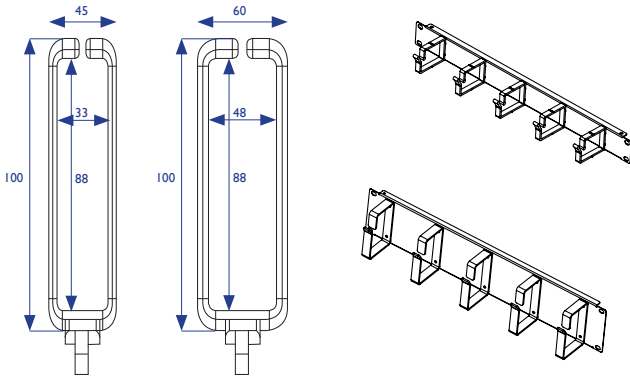

PRODUCT REFERENCE	DESCRIPTION	DIMENSIONS WxH (mm)
K44RING05_01M50	Ring for cable management 45x100mm (1 set = 5 ea.)	45x100
K44RING06_01M50	Ring for cable management 60x100mm (1 set = 5 ea.)	60x100

FINGER TYPE VERTICAL CABLE MANAGER

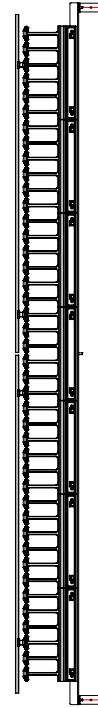

PRODUCT REFERENCE	DESCRIPTION
CLDOR42_02M50	42U Vertical Cable Manager, Finger type with metal cover.
CLDOR45_02M50	45U Vertical Cable Manager, Finger type with metal cover.
CLDOR47_02M50	47U Vertical Cable Manager, Finger type with metal cover.

CloudMax Accessories

VERTICAL METAL CABLE MANAGER



PRODUCT REFERENCE	DESCRIPTION
CLDOR26_03M50	CLOUDMAX 26 U W=780 METAL TYPE VERTICAL ORGANIZER 2PCS_9005 MP
CLDOR32_03M50	CLOUDMAX 32 U W=780 METAL TYPE VERTICAL ORGANIZER 2PCS_9005 MP
CLDOR36_03M50	CLOUDMAX 36 U W=780 METAL TYPE VERTICAL ORGANIZER 2PCS_9005 MP
CLDOR39_03M50	CLOUDMAX 39 U W=780 METAL TYPE VERTICAL ORGANIZER 2PCS_9005 MP
CLDOR42_03M50	CLOUDMAX 42 U W=780 METAL TYPE VERTICAL ORGANIZER 2PCS_9005 MP
CLDOR45_03M50	CLOUDMAX 45 U W=780 METAL TYPE VERTICAL ORGANIZER 2PCS_9005 MP
CLDOR47_03M50	CLOUDMAX 47 U W=780 METAL TYPE VERTICAL ORGANIZER 2PCS_9005 MP

BLANK PANELS

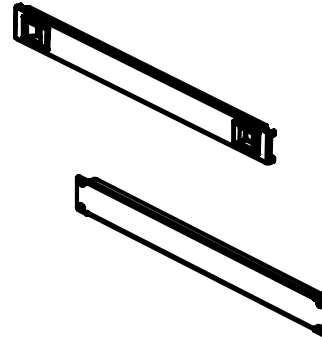

PRODUCT REFERENCE	DESCRIPTION	DIMENSIONS WxHxD (mm)
E44BPN01_0150M	1U 19" Blank panel	483x44x12
E44BPN02_0150M	2U 19" Blank panel	483x88x12
E44BPN03_0150M	3U 19" Blank panel	483x133x12
E44BPN04_0150M	4U 19" Blank panel	483x177x12
E44BPN05_0150M	5U 19" Blank panel	483x222x12
E44BPN06_0150M	6U 19" Blank panel	483x266x12
P44BPN06_01M50	6U 19" Modular plastic blank panel (ABS)	483x266x12

CABLE TRAY

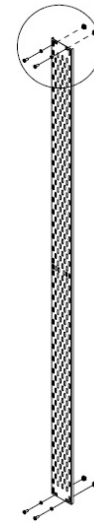

PRODUCT REFERENCE	DESCRIPTION
CT2610	Cable Tray, 26U, w= 100 mm
CT3210	Cable Tray, 32U, w= 100 mm
CT3610	Cable Tray, 36U, w= 100 mm
CT3910	Cable Tray, 39U, w= 100 mm
CT4210	Cable Tray, 42U, w= 100 mm
CT4510	Cable Tray, 45U, w= 100 mm
CT4710	Cable Tray, 47U, w= 100 mm

Note: Color code "M50" is RAL 9005 black, "M2" RAL 7035 light grey option is available

FIXED AND SLIDING SHELVES

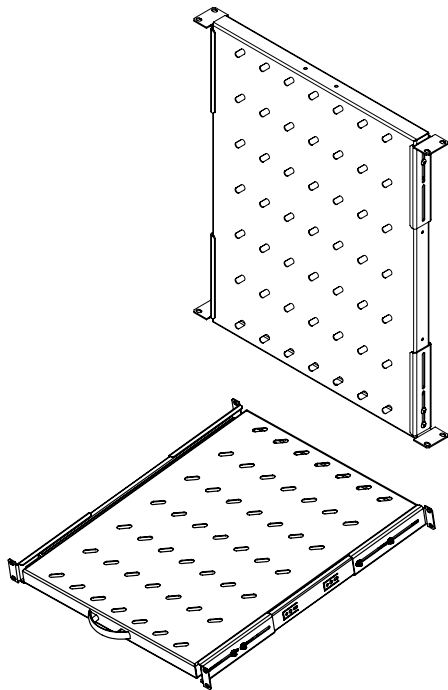

PRODUCT REFERENCE	DESCRIPTION
SHLFIX60M50	D= 600 mm fixed shelf module with slots, load capacity 50 kg., Ral9005, depth of the shelf D= 372 mm, 4-points fixed. Only suitable for 600 mm depth cabinets.
SHLFIX80M50	D= 800 mm fixed shelf module with slots, load capacity 50 kg., Ral9005, depth of the shelf D= 530 mm, 4-points fixed. Only suitable for 800 mm depth cabinets.
SHLFIX100M50	D= 1000 mm fixed shelf module with slots, load capacity 50 kg., Ral9005, depth of the shelf D= 696 mm, 4-points fixed. Only suitable for 1000 mm depth cabinets.
SHLSLD60M50	D= 600 mm sliding shelf module with slots, load capacity 30 kg., Ral9005, depth of the shelf D= 372 mm, 4-points fixed. Only suitable for 600 mm depth cabinets.
SHLSLD80M50	D= 800 mm sliding shelf module with slots, load capacity 30 kg., Ral9005, depth of the shelf D= 530 mm, 4-points fixed. Only suitable for 800 mm depth cabinets.
SHLSLD100M50	D= 1000 mm sliding shelf module with slots, load capacity 30 kg., Ral9005, depth of the shelf D= 696 mm, 4-points fixed. Only suitable for 1000 mm depth cabinets.

19" KEYBOARD DRAWER

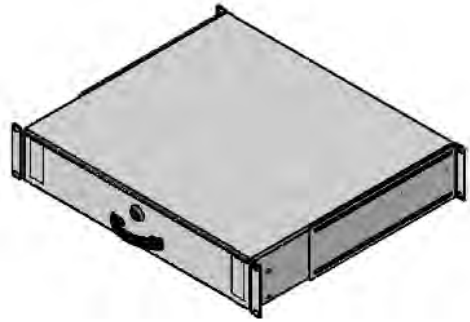

PRODUCT REFERENCE	DESCRIPTION	DIMENSIONS WxHxD (mm)
M44CEK2U_01M50	2U 19" drawer, lockable suitable up to depth=800mm. Cabinets, for D=1000 mm cabinet usage extra brackets available in package, sheet steel material and load carrying capacity is 25 kg.	483x88x400
M44CEK3U_01M50	3U 19" drawer, lockable suitable up to depth=800mm. Cabinets, for D=1000 mm cabinet usage extra brackets available in package, sheet steel material and load carrying capacity is 25 kg.	483x133x400

PDU HOLDER

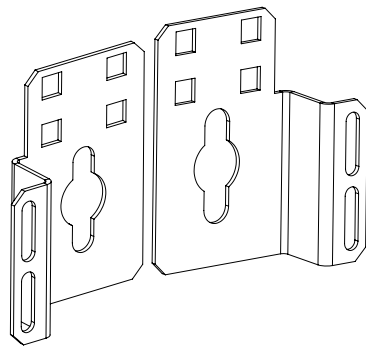

PRODUCT REFERENCE	DESCRIPTION
PDUHM01_M50	PDU holder, 1 set= 2 pcs, for 1 PDU

Note: Color code "M50" is RAL 9005 black, "M2" RAL 7035 light grey option is available

CloudMax Accessories

FAN MODULES

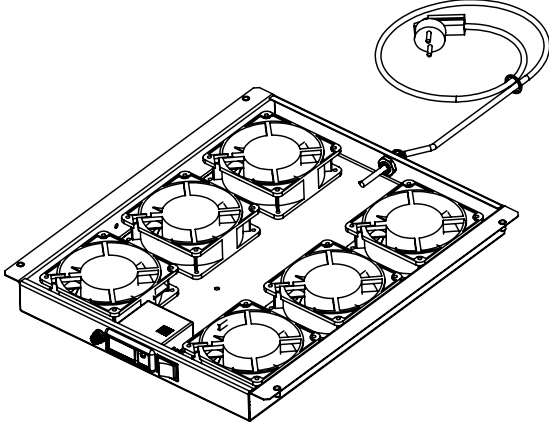

PRODUCT REFERENCE	DESCRIPTION
FAN4DT4F01_M50	Fan module, 4 fan + digital thermostat, 2P+E plug, schuko std., 4 pre-cut hole
FAN4DT4F02_M50	Fan module, 4 fan + digital thermostat, 2P+E plug, UK std., 4 pre-cut hole
FAN4OO4F01_M50	Fan module, 4 fan + On/Off, 2P+E plug, schuko std., 4 pre-cut hole
FAN4OO4F02_M50	Fan module, 4 fan + On/Off, 2P+E plug, UK std., 4 pre-cut hole
FAN4AT4F01_M50	Fan module, 4 fan + analog thermostat, 2P+E plug, schuko std., 4 pre-cut hole
FAN4AT4F02_M50	Fan module, 4 fan + analog thermostat, 2P+E plug, UK std., 4 pre-cut hole
FAN6DT6F01_M50	Fan module, 6 fan + digital thermostat, 2P+E plug, schuko std., 6 pre-cut hole
FAN6DT6F02_M50	Fan module, 6 fan + digital thermostat, 2P+E plug, UK std., 6 pre-cut hole
FAN6OO6F01_M50	Fan module, 6 fan + On/Off, 2P+E plug, schuko std., 6 pre-cut hole
FAN6OO6F02_M50	Fan module, 6 fan + On/Off, 2P+E plug, UK std., 6 pre-cut hole
FAN6AT6F01_M50	Fan module, 6 fan + analog thermostat, 2P+E plug, schuko std., 6 pre-cut hole
FAN6AT6F02_M50	Fan module, 6 fan + analog thermostat, 2P+E plug, UK std., 6 pre-cut hole

FIXINGS

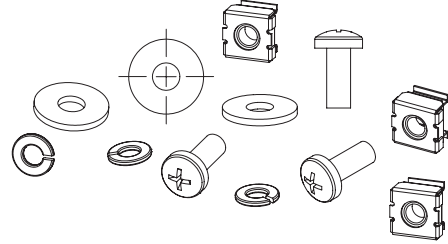

PRODUCT REFERENCE	DESCRIPTION
KFS6X15_20	M6 caged nut, screw, washer (1set=20ea)
KFS6X15_50	M6 caged nut, screw, washer (1set=50ea)

GROUNDING KIT

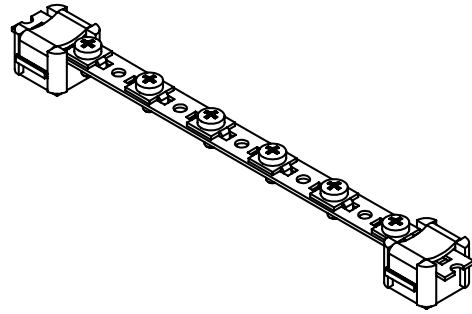

PRODUCT REFERENCE	DESCRIPTION
M44PEB01	Grounding kit, 6 each earthing leads + copper busbar
M44PEB19_01	Grounding kit, 13 each earthing leads + copper busbar

Note: Color code "M50" is RAL 9005 black, "M2" RAL 7035 light grey option is available

CloudMax Corridor Solutions

TOP PANEL CORRIDOR DOORS

Easy fixable top panel using for close the top of hot/cold aisle containment. Polycarbonate (4 mm) closing with reinforced metal frame. Glass option is available.

TOP COVER CABLE SEPARATOR (A TYPE)

Separate cable inlet for data and energy cables, and separate overhead cable trays and dividers minimize the electromagnetic and physical interference. A type separator have h=120 mm. and w=600/800 mm. option.

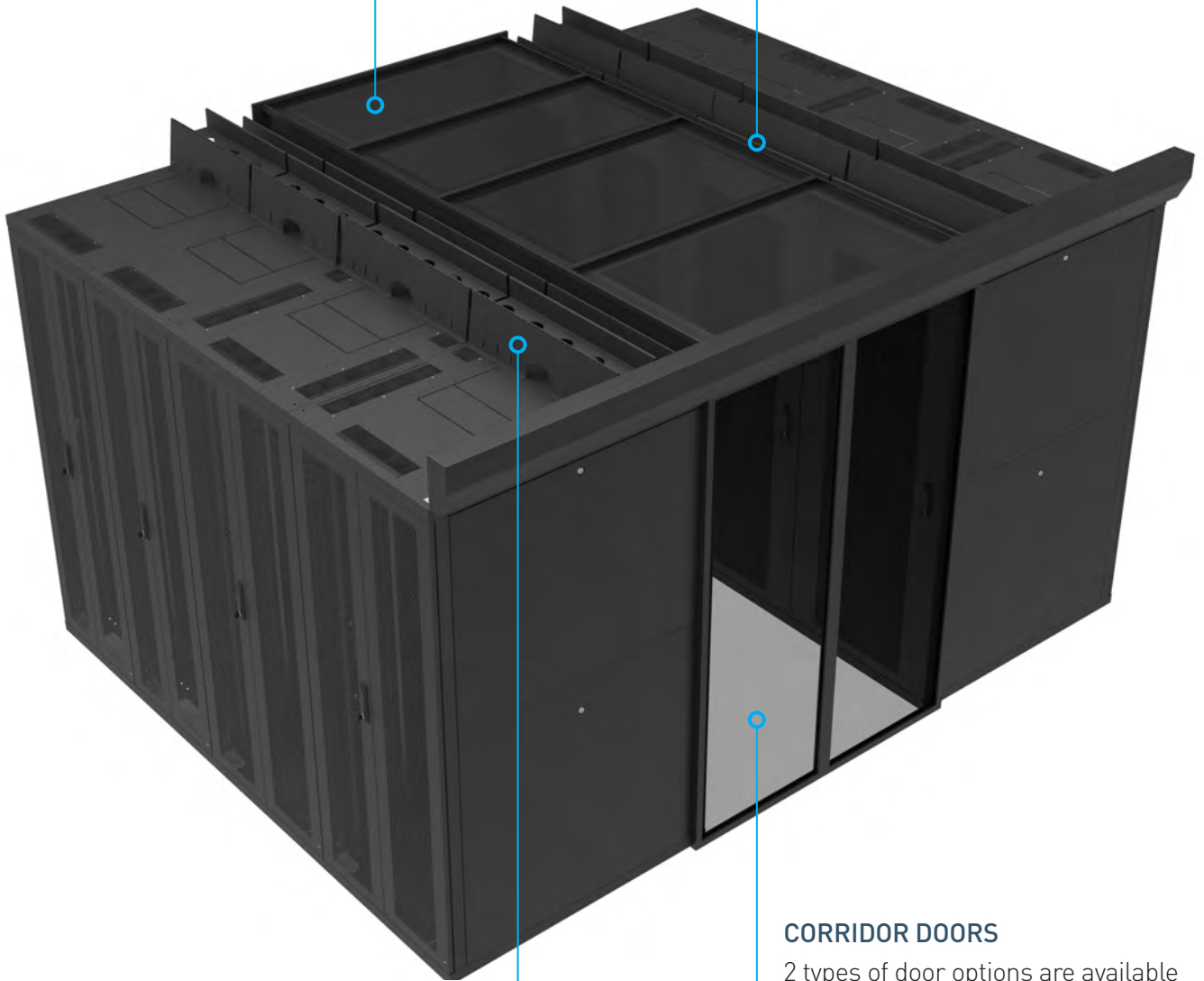

TOP COVER CABLE SEPARATOR (M TYPE)

CloudMax cabinets offer professional and highly secured management of high density data and power cables. M Type separator have h=200 mm. and w=600/800 mm. options.

CORRIDOR DOORS

2 types of door options are available as automatic opening and manual opening. Dimensions: 42/45/47U 600 or 1200/1500/1800 mm. Automatic door opening and exit with hand sensor. Keypad or proximity card lock is available. Lock to the bottom option is suitable for manual opening.

CloudMax Corridor Solutions

AUTOMATIC OPENING

2 types of door options are available as automatic opening and manuel opening. System is CE, TUV and ISO certificated.

Automatic Opening

Wing Frame Metarial: Aluminium.

Glass: 4+4mm transparent laminated glass.

Carrier System: 5 x 60 x 120mm – 4x brackets; 40 x 60 x 2mm Alm. Profile posts.

Carrier wide: 3200mm – 3600mm*

Security Sensor: Active 8 curtain photocell sensor.

Mechanism Wide: 2500mm.

Corridor Wide: 1200 x 2240mm.

Wings: 2 x moving wings, automatic.

Locking: Electro-mechanic locking systems.

Locking Options: Keypad or Proximity Card.

Colour: RAL 9005 and RAL 7035.



MANUEL OPENING

Manuel Opening

Wing Frame Metarial: Aluminium.

Glass: 4+4mm transparent laminated glass.

Carrier System: 5 x 60 x 120mm – 4x brackets; 40 x 60 x 2mm Alm. Profile posts.

Carrier wide: 3200mm – 3600mm*

Mechanism Wide: 2500mm

Corridor Wide: 1200mm

Wings: 2 x synchronized wings.

Locking: Lock to the bottom.

Colour: RAL 9005 and RAL 7035

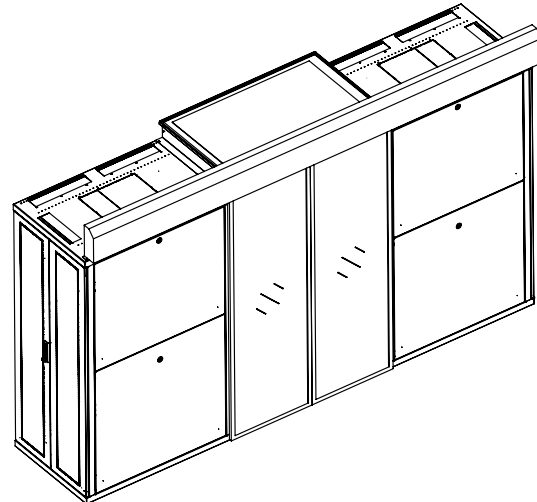

PRODUCT REFERENCE	DESCRIPTION
DCCD4212_01M50	42U Corridor door, double opening, w= 1200 mm, tempered glass, opening and exit with hand sensor
DCCD4215_01M50	42U Corridor door, double opening, w= 1500 mm, tempered glass, opening and exit with hand sensor
DCCD4218_01M50	42U Corridor door, double opening, w= 1800 mm, tempered glass, opening and exit with hand sensor
DCCD4512_01M50	45U Corridor door, double opening, w= 1200 mm, tempered glass, opening and exit with hand sensor
DCCD4515_01M50	45U Corridor door, double opening, w= 1500 mm, tempered glass, opening and exit with hand sensor
DCCD4518_01M50	45U Corridor door, double opening, w= 1800 mm, tempered glass, opening and exit with hand sensor
DCCD4712_01M50	47U Corridor door, double opening, w= 1200 mm, tempered glass, opening and exit with hand sensor
DCCD4715_01M50	47U Corridor door, double opening, w= 1500 mm, tempered glass, opening and exit with hand sensor
DCCD4718_01M50	47U Corridor door, double opening, w= 1800 mm, tempered glass, opening and exit with hand sensor

*Depends to the cabinets depth.

Note 1: Color code "M50" is RAL 9005 black, "M2" RAL 7035 light grey option is available.

Note 2: For the entrance and/or exit of the sliding doors by push button or any kind of access options please refer to the sales office.

TOP PANEL MODULE (4MM)

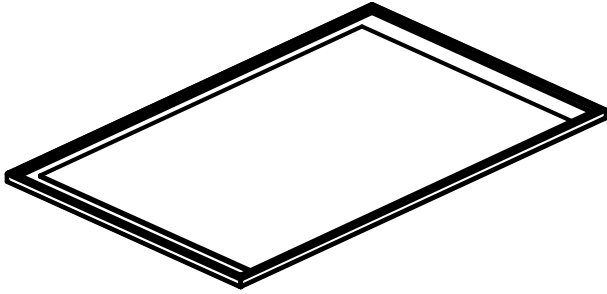

PRODUCT REFERENCE	DESCRIPTION
DCTP6012_01M50	Top panel module, 600X1200 mm
DCTP6012_02M50	Top panel edge module, 600X1200 mm
DCTP6015_02M50	Top panel edge module, 600x1500 mm
DCTP6015_01M50	Top panel module, 600X1500 mm
CLDTP7812_01M50	Top panel module, 800X1200 mm
CLDTP7812_02M50	Top panel edge module, 800X1200 mm
CLDTP7815_02M50	Top panel edge module, 800X1500 mm
CLDTP7815_01M50	Top panel module, 800X1500 mm
CLDTP7818_02M50	Top panel edge module, 800X1800 mm
CLDTP7818_01M50	Top panel module, 800X1800 mm

TOP COVER PANEL

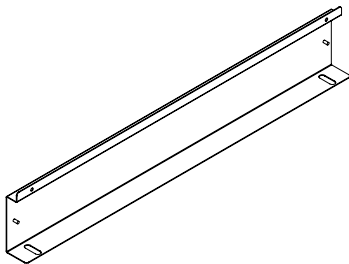

PRODUCT REFERENCE	DESCRIPTION
DCTCP6012_M50	Top cover panel, w= 600 mm, h= 120 mm
CLDTC7812_M50	Top cover panel, w= 800 mm, h= 120 mm

TOP COVER CABLE SEPERATOR (A AND M TYPE)

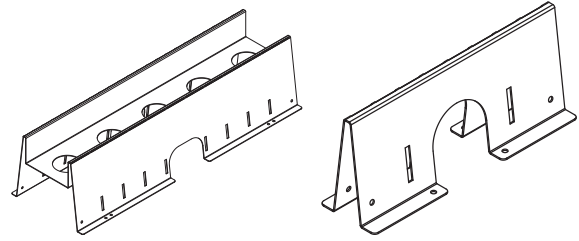

PRODUCT REFERENCE	DESCRIPTION
DCTCCS6012_01M50	01M50 Top cover cable seperator, h= 120 mm, w= 600 mm, A type
CLDTCCS7812_01M50	Top cover cable seperator, h= 120 mm, w= 800 mm, A type
DCTCCS6020_02M50	Top cover cable seperator, h= 200 mm, w= 600 mm, M type
CLDTCCS7820_02M50	Top cover cable seperator, h= 200 mm, w= 800 mm, M type

BAYING KIT

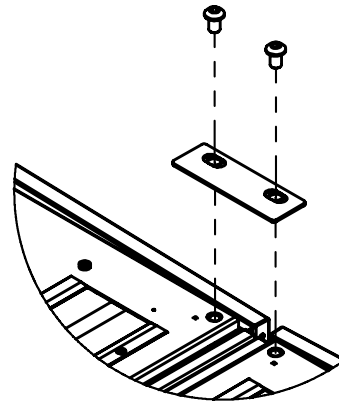

PRODUCT REFERENCE	DESCRIPTION
CLDBK_01M50	Baying kit, 1 set= 2 pcs.

CORRIDOR DOOR FIXING MODULE

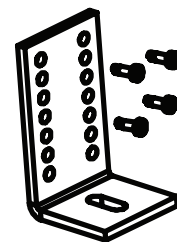

PRODUCT REFERENCE	DESCRIPTION
DCCDFM_01M50	Corridor door fixing module, 8 cm top cover panel

Note: Color code "M50" is RAL 9005 black, "M2" RAL 7035 light grey option is available

CloudMax

CORRIDOR REAR PANEL MODULES

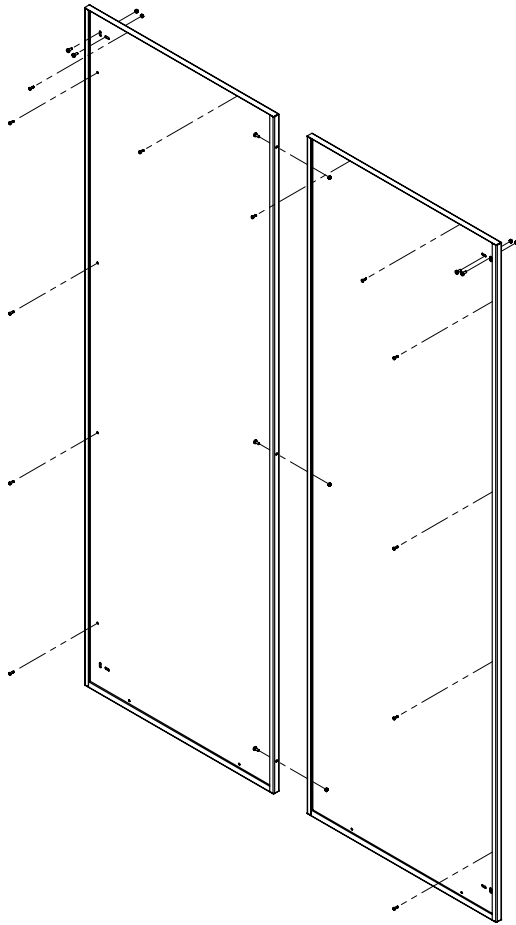

PRODUCT REFERENCE	DESCRIPTION
CLDCRPM4212_01M50	Corridor rear panel modules, 42U, h=1200 mm
CLDCRPM4215_01M50	Corridor rear panel modules, 42U, h=1500 mm
CLDCRPM4218_01M50	Corridor rear panel modules, 42U, h=1800 mm
CLDCRPM4712_01M50	Corridor rear panel modules, 47U, h=1200 mm
CLDCRPM4715_01M50	Corridor rear panel modules, 47U, h=1500 mm
CLDCRPM4718_01M50	Corridor rear panel modules, 47U, h=1800 mm

AIRFLOW PREVENTATIVE PANEL

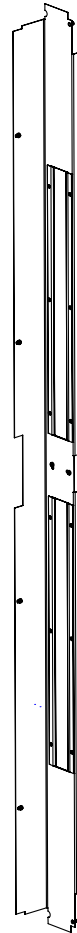

PRODUCT REFERENCE	DESCRIPTION
CLDAFPTBP4260_M50	Airflow preventative panel, 42U, w=600 mm, top and bottom
CLDAFPTBP4278_M50	Airflow preventative panel, 42U, w=800 mm, top and bottom
CLDAFPSP4260_M50	Airflow preventative panel, 42U, w=600 mm, side
CLDAFPSP4560_M50	Airflow preventative panel, 45U, w=600 mm, side
CLDAFPSP4760_M50	Airflow preventative panel, 47U, w=600 mm, side
CLDAFPSP4280_M50	Airflow preventative panel, 42U, w=800 mm, side
CLDAFPSP4580_M50	Airflow preventative panel, 45U, w=800 mm, side
CLDAFPSP4780_M50	Airflow preventative panel, 47U, w=800 mm, side

TECHNICAL CHARACTERISTICS

INDEX OF PROTECTION

■ IP20 according to EN61587-1, IEC60529 IP20: Protected against solid objects larger than 12,5 mm in diameter

FRONT DOOR STRUCTURE

- Produced from galvanised sheet metal.
- The door has 80% or 63% perforations to have a good air flow.
- Provides enough space for patch cords between door and equipment.
- Can open 220°.

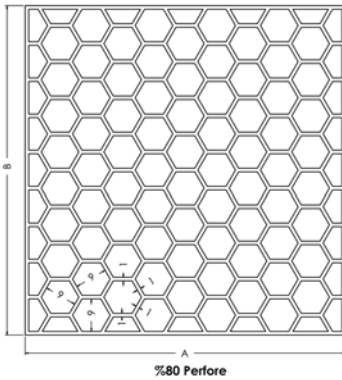

LOCKING MECHANISM

3 point lock, handle with semi cylindrical barrel.
Hinge System:
3 pcs Zinc alloy Steel to fix the door.

SIDE PANEL STRUCTURE

- Produced from DKP sheet metal.
- Thickness is 1 mm.
- Fixed to cabinet by cylindrical lock.
- 2 pcs in one side.

REAR DOOR STRUCTURE

- Produced from DKP sheet metal.
- The flat door has 80% or 63% perforations to have a good air flow.
- Can open 220°.

LOCKING MECHANISM

3 point lock, handle with semi cylindrical barrel

HINGE SYSTEM:

3 pcs Zinc alloy Steel to fix the door.

ROOF STRUCTURE

- Produced from DKP sheet metal.
- Suitable to fan module fixing.
- Plenty of cable entry possibility.
- Brush type cable entries.

TESTS AND COMPLIED STANDARDS

TESTS AND COMPLIED STANDARDS

- 1) ISO 9001:2015 Quality Management System
- 2) ISO 14001:2015 Environmental Management System
- 3) ISO 27001:2013 Information Security Management System
- 4) ISO 45001:2018 Occupational Health and Safety Management System
- 5) 19" device mounting uprights IEC 297-1
- 6) EN 61587-1 Mechanical structures for electronic equipment.
- 7) All cabinet sizes complies with IEC 297-2.

**RESISTANCE TO ENVIRONMENTAL CONDITIONS AND CORROSION;
STABILITY, MECHANICAL SAFETY, RESISTANCE TO STATIC, DYNAMIC AND MECHANICAL LOADS;**

**RESISTANCE TO VIBRATION, MECHANICAL SHOCK AND IMPACT;
DEGREES OF MECHANICAL PROTECTION PROVIDED BY THE ENCLOSURE (IP20);
ELECTRICAL GROUNDING CONTINUITY;**

FIRE AND FLAME RESISTANCE;

Have been tested according to the standard " EN 61587-1" with the normative standards: IEC 60917, IEC 60297, IEC 60068-1, IEC 60068-2, IEC 60695-11-10, IEC 60950-1, contained and certified by the notified organizations:

TSE CERTIFICATE NO

003788-TSE-08/02

EAC CERTIFICATE NO

0443637, 0776963, 0345864, 0401678, 0776653

CORROSION

ISO 9227 Standard complied by the test report METALTEK AB-0547-T / 0157-1

TRANSPORT

ETS 300 019-1-2 Class 2.3 Comply with internal testing

STORAGE

ETS 300 019-1-1 Class 1.2 Comply with internal testing

SURFACE FINISH

Electrostatic powder coated c/with surface treatment , 80 +/- 5 micron paint thickness

PURCHASED PRODUCT CERTIFICATION

SHEET STEEL

EN 10346: 20015 DX51D+Z, EN 10130: 2006 DC01

ELECTROSTATIC POWDER COATING

ISO6860, ISO2409, ISO1520, ISO2815, ISO6272, ISO7253, ISO6270-1, ISO2812

ISO 9001, RoHS

GLASS

TS EN 12150-1, TS EN 1863-1

LOCK

IEC 62474, REACH, RoHS

CASTORS

ISO 9001, TS EN 12532, RoHS

FAN

IEC 60335-2-80:2002, IEC 60335-1:2010

UniversalLine

Intro

Universalline cabinets are suitable for office, equipment rooms, infrastructural cabling of civil engineering, telecommunication and IT networks.



GENERAL CHARACTERISTICS

- Wide range of sizes from 16U to 47U
- 600 and 780 mm width, 600, 800 and 1000 mm depth options
- Load carrying capacity 1000 kg
- Depth adjustable 19" mounting uprights even when the cabinet is fully loaded
- 4 way access; removable, lockable doors and side panels
- Easy disassembling structure with spring hinge system
- 115 degree front/rear door openings
- Baying kit option



HIGH CABLING CAPACITY WITH EXTENSIVE CABLE ENTRIES

Universalline 19' free standing cabinets comply with all international standards in professional networking.

- Main structure has 24 fold frames for increased stability
- Front glass door and metal rear door in standard, perforated and/or solid metal doors are the other options
- Single and double metal rear door construction with brushed cable entry on top and bottom
- Front doors have a framed glass structure which is tempered, anti-static, secure and smoked glass(4 mm thickness)
- Cables protected and fixed by rubber edge sliding cover
- More efficient passive ventilation with Pagoda style top cover
- Plint, floor fixing kit, casters besides standard leveling feet
- EN 61587, IEC 60917, IEC 60297 standards, RoHS compliancy, EAC and TSE certified
- Electrostatic powder coated with RAL 9005 (Black) and RAL (7035) options



UniversalLine

PRODUCT REFERENCE

PRODUCT REFERENCE*	U HEIGHT	WIDTH OVERALL (mm)	DEPTH OVERALL (mm)	DEPTH MAX MOUNTING (mm) PROFILE	HEIGHT VERTICAL MOUNTING PROFILE (mm)	HEIGHT WITHOUT LEVELLING FEET (mm)	HEIGHT WITH LEVELLING FEET (mm)	HEIGHT WITH CASTERS (mm)
UNC16U6060...	16	600	600	390	715	865	880	945
UNC16U6080...	16	600	800	555	715	865	880	945
UNC20U6060...	20	600	600	390	890	1042	1057	1122
UNC20U6080...	20	600	780	555	890	1042	1057	1122
UNC22U6060...	22	600	600	390	980	1131	1146	1211
UNC22U6080...	22	600	780	555	980	1131	1146	1211
UNC22U8080...	22	800	780	555	980	1131	1146	1211
UNC26U6060...	26	600	600	390	1160	1309	1324	1389
UNC26U6080...	26	600	780	555	1160	1309	1324	1389
UNC26U6010...	26	600	1000	740	1160	1309	1324	1389
UNC26U8080...	26	800	780	555	1160	1309	1324	1389
UNC26U8010...	26	800	1000	740	1160	1309	1324	1389
UNC32U6060...	32	600	600	390	1422	1576	1591	1656
UNC32U6080...	32	600	780	555	1422	1576	1591	1656
UNC32U6010...	32	600	1000	740	1422	1576	1591	1656
UNC32U8080	32	800	780	555	1422	1576	1591	1656
UNC32U8010	32	800	1000	740	1422	1576	1591	1656
UNC36U6060...	36	600	600	390	1603	1754	1769	1834
UNC36U6080...	36	600	780	555	1603	1754	1769	1834
UNC36U6010...	36	600	1000	740	1603	1754	1769	1834
UNC36U8080...	36	800	780	555	1603	1754	1769	1834
UNC36U8010...	36	800	1000	740	1603	1754	1769	1834
UNC39U6060...	39	600	600	390	1735	1887	1902	1967
UNC39U6080...	39	600	780	555	1735	1887	1902	1967
UNC39U6010...	39	600	1000	740	1735	1887	1902	1967
UNC39U8080...	39	800	780	555	1735	1887	1902	1967
UNC39U8010...	39	800	1000	740	1735	1887	1902	1967
UNC42U6060...	42	600	600	390	1889	2021	2036	2101
UNC42U6080...	42	600	780	555	1889	2021	2036	2101
UNC42U6010...	42	600	1000	740	1889	2021	2036	2101
UNC42U8060...	42	800	600	390	1889	2021	2036	2101
UNC42U8080...	42	800	780	555	1889	2021	2036	2101
UNC42U8010...	42	800	1000	740	1889	2021	2036	2101
UNC45U6060...	45	600	600	390	2020	2153	2168	2233
UNC45U6080...	45	600	780	555	2020	2153	2168	2233
UNC45U6010...	45	600	1000	740	2020	2153	2168	2233
UNC45U8080...	45	800	780	555	2020	2153	2168	2233
UNC45U8010...	45	800	100	740	2020	2153	2168	2233
UNC47U6060...	47	600	600	390	2110	2244	2259	2324
UNC47U6080...	47	600	780	555	2110	2244	2259	2324
UNC47U6010...	47	600	1000	740	2110	2244	2259	2324
UNC47U8080...	47	800	780	555	2110	2244	2259	2324
UNC47U8010...	47	800	1000	740	2110	2244	2259	2324

* Pls complete the reference code referring the "Reference Code Creation" on next page.

DOOR SELECTION TABLE AND REFERENCE CODE CREATION

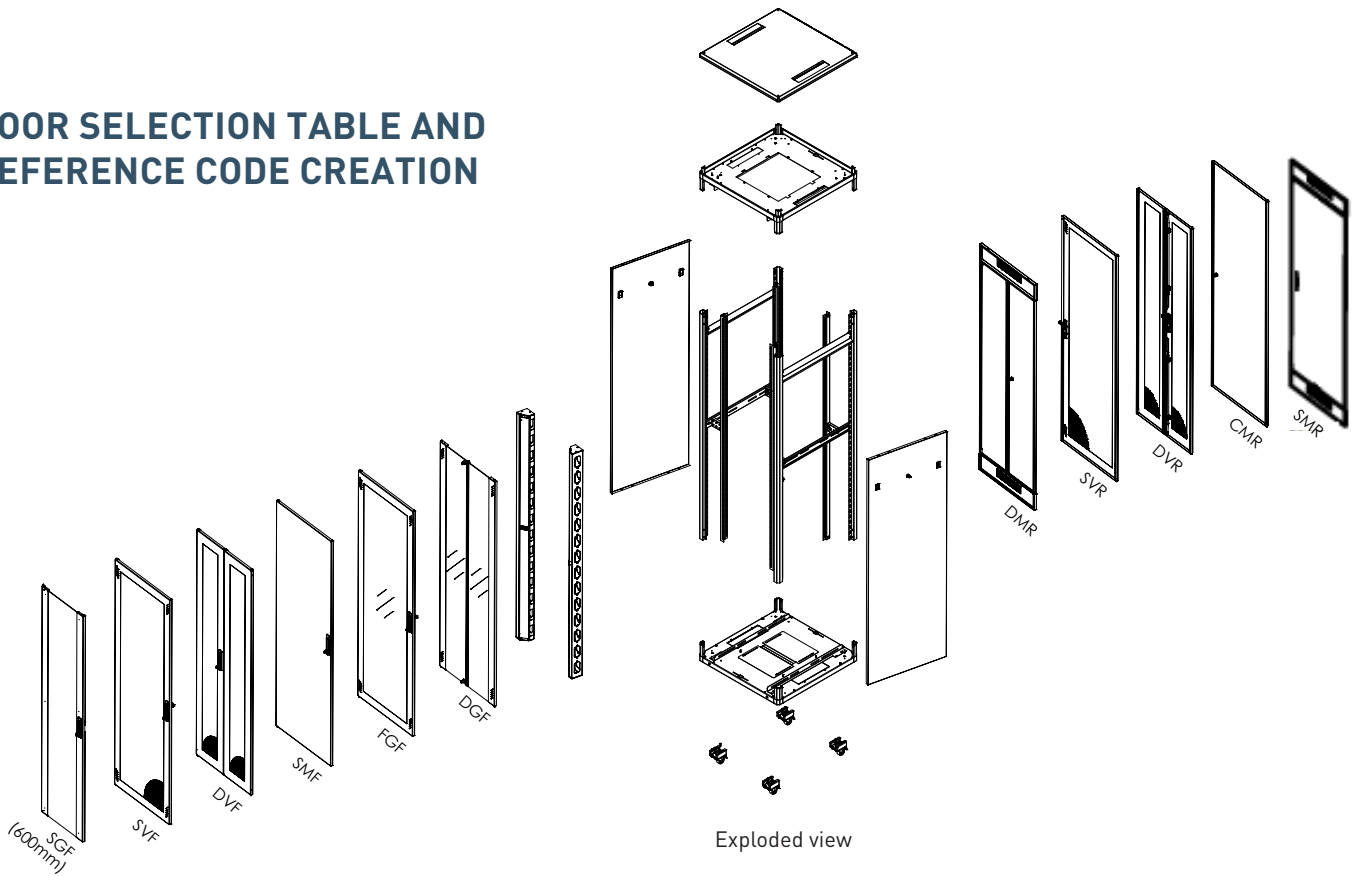

DOOR CODE	DESCRIPTION	UNC W= 600 MM	UNC W= 800 MM
FRONT			
SGF	Single Glass Front Door, single point locking	Standard	
DGF	Double Glass Front Door, two point barrel locking		Standard
FGF	Single, Full Frame Glass Front Door, single point locking	Optional	Optional
SVF	Single Vented Front Door, 63% perforated, single point locking	Optional	Optional
DVF	Double Vented Front Door, 63% perforated, three point locking		Optional
SMF	Solid Metal Front Door	Optional	Optional
REAR			
CMR	Single Solid Metal Rear Door	Optional	Optional
DMR	Double Solid Metal Rear Door with cable entries on top and bottom	Optional	Standard
SVR	Single Vented Rear Door, 63% perforated, single point locking	Optional	Optional
DVR	Double Vented Rear Door, 63% perforated, three point locking	Optional	Optional
SMR	Solid Metal Rear Door(s) with cable entries on top & bottom	Standard	Optional

Marked are also Default Config.

REFERENCE CODE CREATION

Example: UNC47U8080_M2_L_DVFSVR

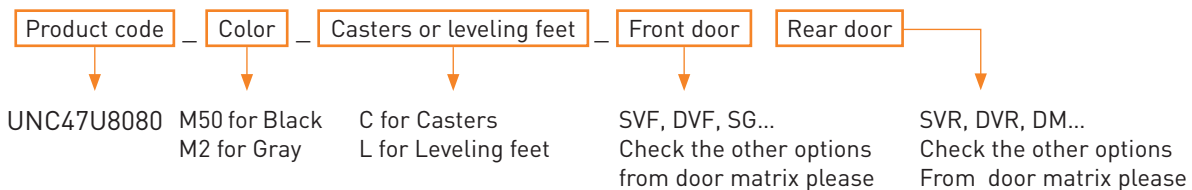

TECHNICAL DRAWINGS
W=600 mm CABINETS

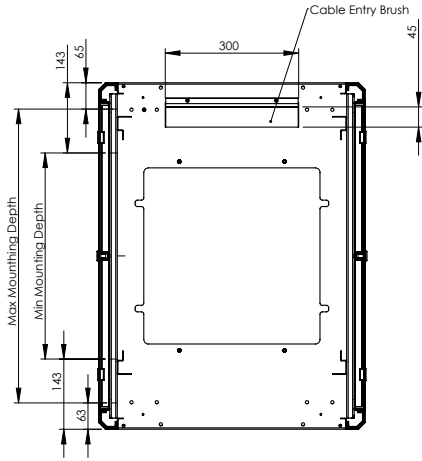

Top view

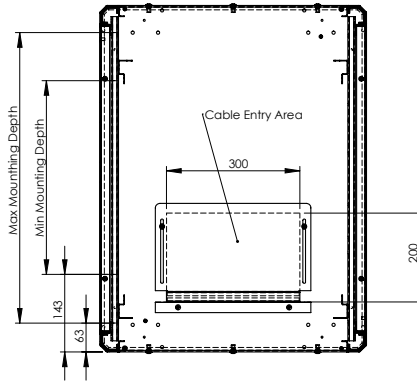

Bottom view

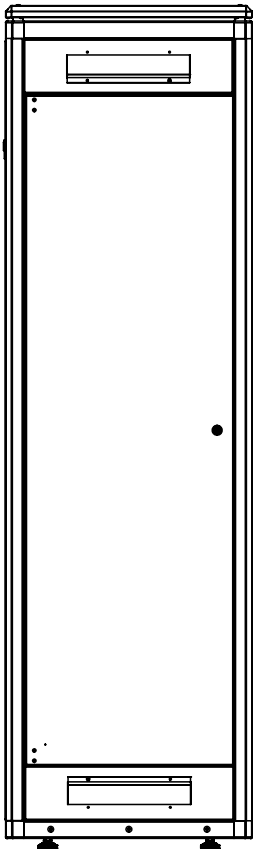

Back view

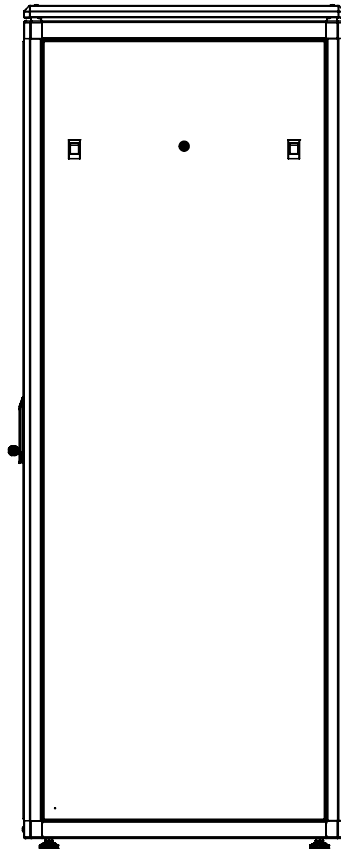

Side view

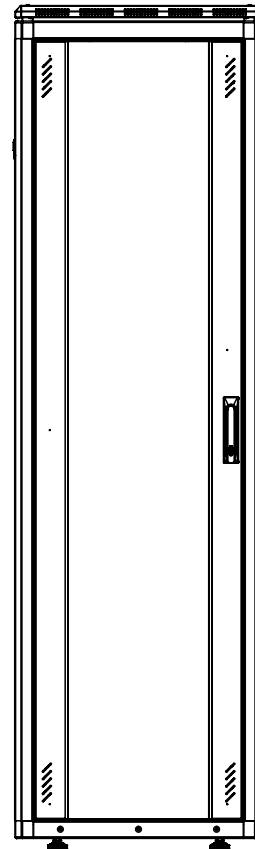

Front view

H= Enclosure height

TECHNICAL DRAWINGS

W=800 mm CABINETS

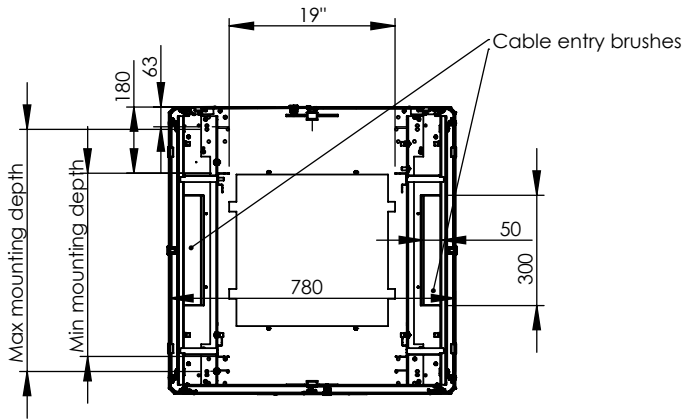

Top view

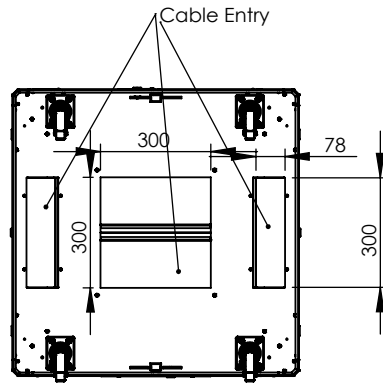

Bottom view

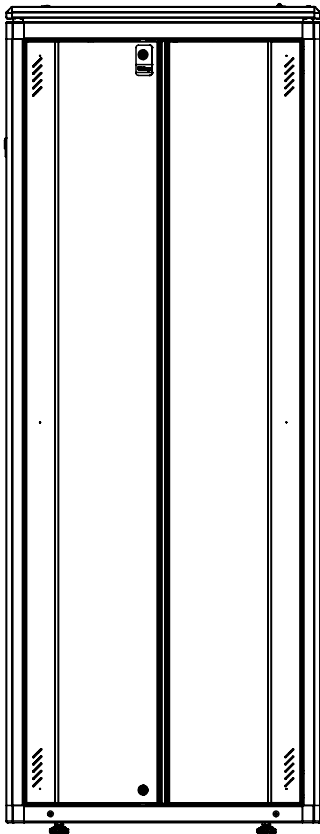

Front view

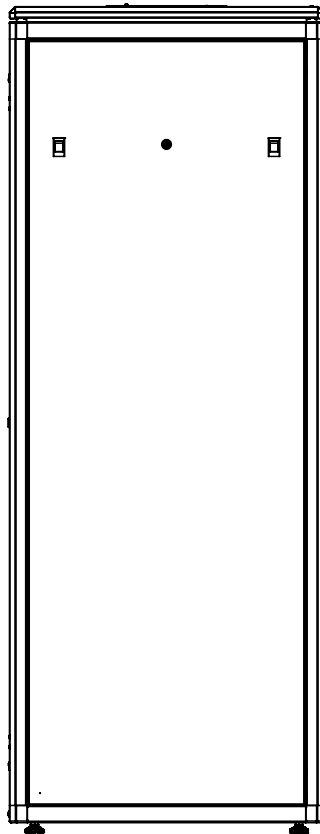

Side view

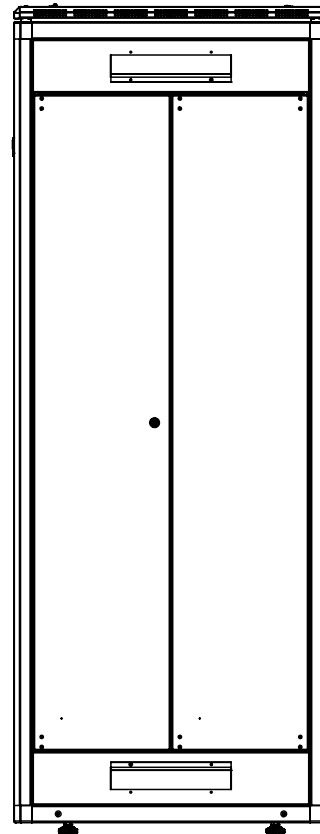

Back view

H= Enclosure height

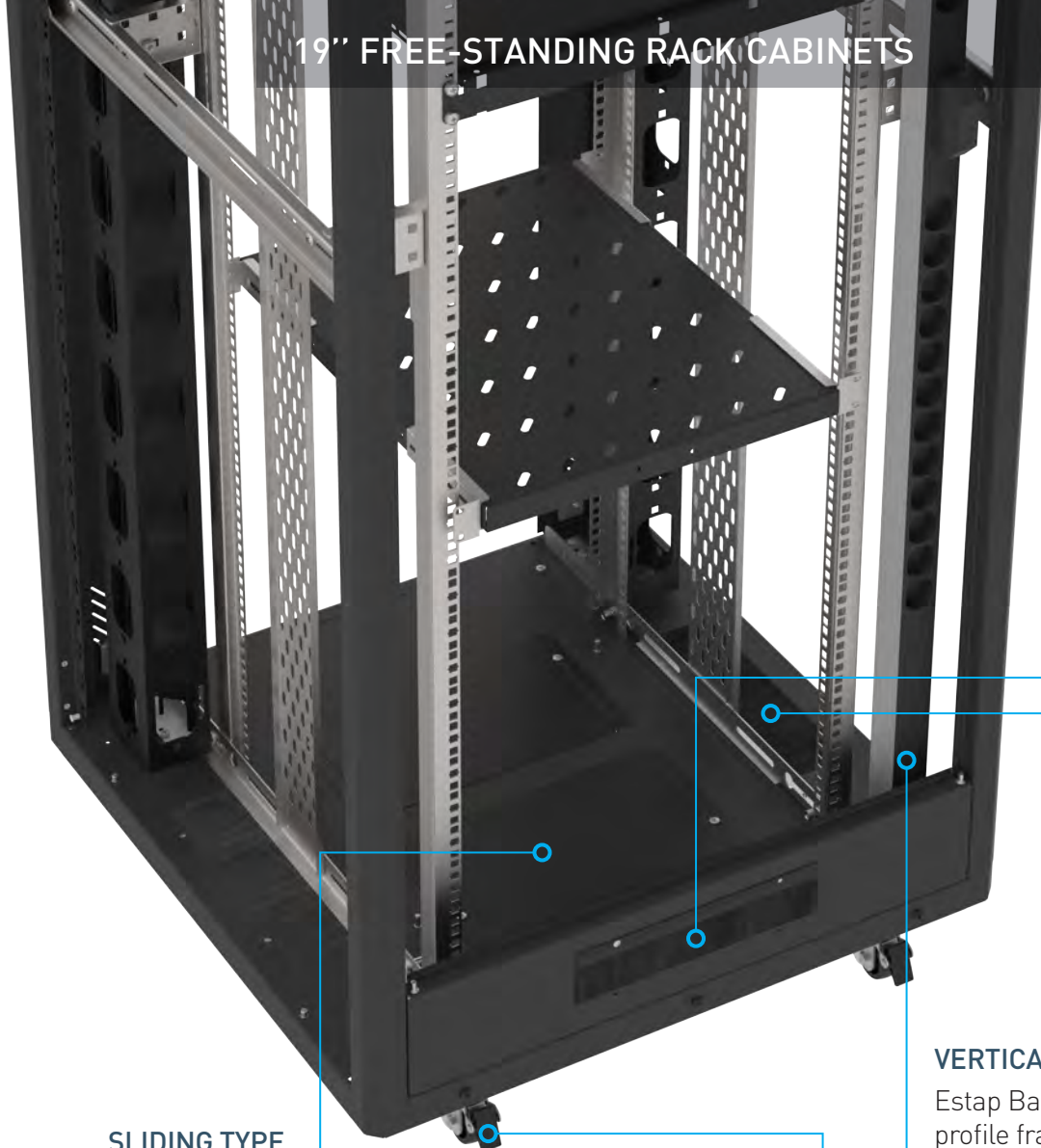

SLIDING TYPE CABLE ENTRY

Bottom panel have two cable entries which are sliding type with rubber edges.

CASTER AND LEVELLING FEET

Rotational type casters, 2 pieces front have lockable function
Levelling feet: Height adjustment from the floor 250 kg. load carrying capacity of each wheel and each levelling feet.

VERTICAL BASIC PDU

Estep Basic pdu has aluminium profile frame, on/off switch and circuit breaker options. Schuko, C13-C19 and UK socket types are available.

FLOOR FIXING KIT

Fixing the cabinet to floor for better stability. 4-point fixing. Galvanized sheet metal.

LED LIGHT

Effective and powerful lighting. Different dimensions 19", 1U, with ON/OFF switch, automatic door with ON/OFF switch or LED with sensor.



FAN MODULE

2 or 4 pcs. of fan on a module, with ON/OFF, analog or digital thermostat functions. Complete inner wiring. 1U

GROUNDING CONTINUITY

Grounding cables for all metal components. Cable connections with bolts and nuts for all doors.

UniversalLine Accessories

FIXED AND SLIDING SHELF

Fixing points at the sides of rear and front 19" uprights.

Vented for air circulation, adjustable depth, sheet steel material. Available for all kind of cabinet depths like 600mm, 800mm and 1000mm.

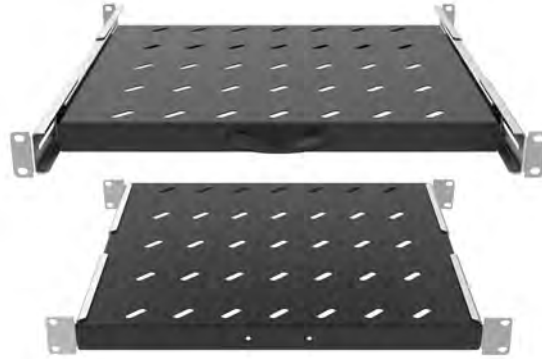

BRUSHED CABLE ENTRY

There are two brushed cable entries on the bottom and top panels.

CABLE TRAY

Options from 16U to 47U. The galvanized coating must be perforated to provide length and cable installation along the height of the cabinet. Unified cable tray for every cabinet range.

DOOR CABLE ENTRY

Optional brushed top and bottom door cable entries.

VERTICAL CABLE ORGANIZER

Options from 16U to 47U. Large internal volume that protects all kind of electric and data cables and patch cords. It attaches to the sides along 19" uprights and have cable entry holes.

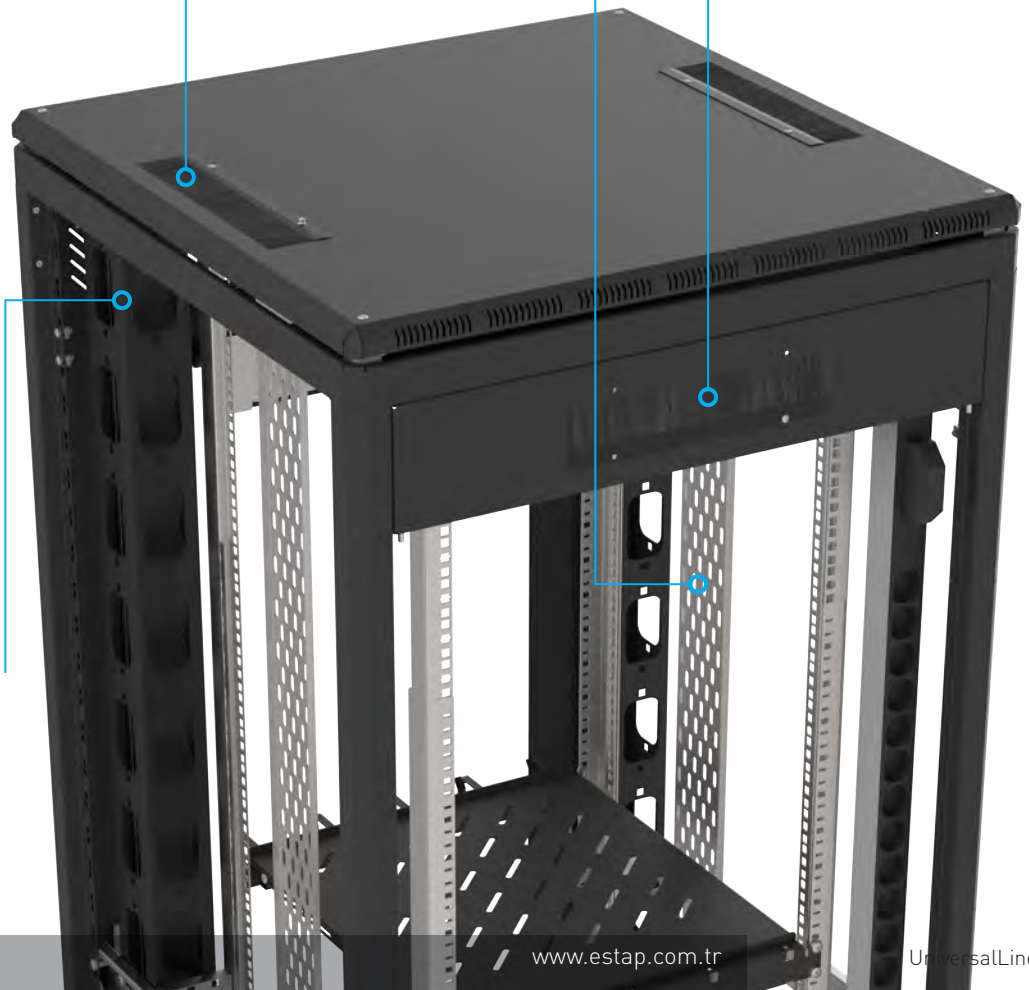

The image is for the width of 800 mm cabinet

UniversalLine Accessories

CASTER AND LEVELLING FEET

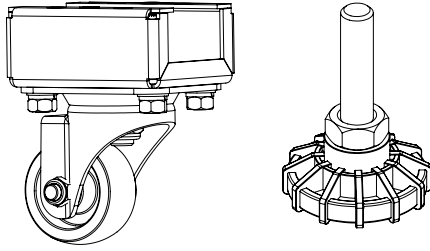

PRODUCT REFERENCE	DESCRIPTION
M44STB01_01TKR_CKR	Casters, 2 pcs. front are lockable
MG44STB01_01PNY_CKR	Levelling feet (1 set = 4 pcs.)

HEAVY DUTY TYPE SHELF

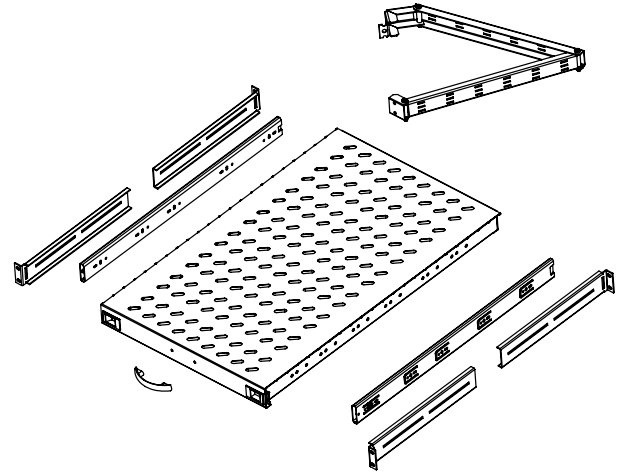
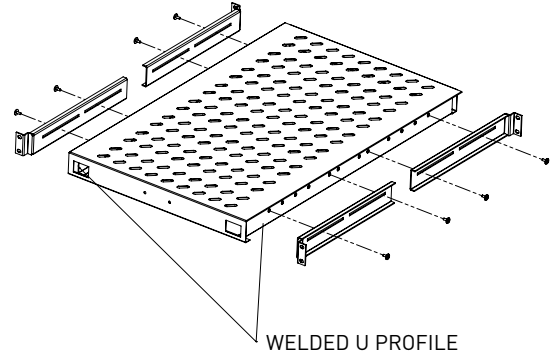

PLINTH

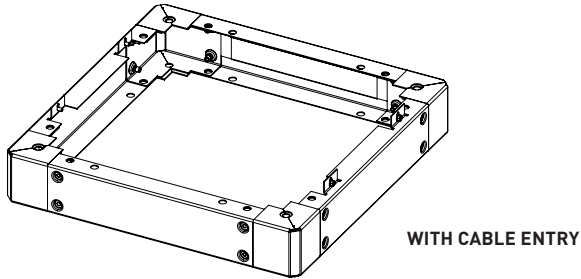

PRODUCT REFERENCE	DESCRIPTION
M11PNT66_01M50	Plinth with cable entry for Universalline, Width=600 mm / depth=600 mm
M11PNT68_01M50	Plinth with cable entry for Universalline, Width=600 mm / depth=800 mm
M11PNT610_01M50	Plinth with cable entry for Universalline, Width=600 mm / depth=1000 mm
M11PNT88_01M50	Plinth with cable entry for Universalline, Width=800 mm / depth=800 mm
M11PNT810_01M50	Plinth with cable entry for Universalline, Width=800 mm / depth=1000 mm

PRODUCT REFERENCE	DESCRIPTION	HxWxD (mm)
M55SR720_01M50	19", heavy duty fixed shelf, adjustable in depth	50x483x720
M55HR720_01M50	19", heavy duty sliding shelf, adjustable in depth, vented, complete with rear cable management system	50x483x720

Note: Color code "M50" is RAL 9005 black, "M2" RAL 7035 light grey option is available

19" KEYBOARD DRAWER

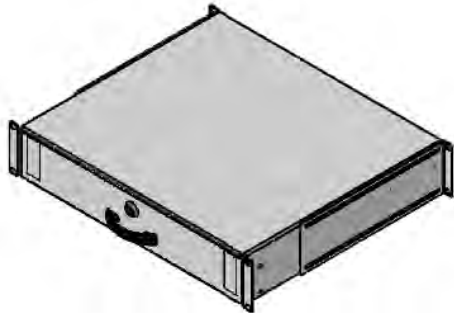

PRODUCT REFERENCE	DESCRIPTION	DIMENSIONS WxHxD (mm)
M44CEK2U_01M50	2U 19" drawer, lockable suitable up to depth=800mm. Cabinets, for D=1000 mm cabinet usage extra brackets available in package, sheet steel material and load carrying capacity is 25 kg.	483x88x400
M44CEK3U_01M50	3U 19" drawer, lockable suitable up to depth=800mm. Cabinets, for D=1000 mm cabinet usage extra brackets available in package, sheet steel material and load carrying capacity is 25 kg.	483x133x400

FIXED AND SLIDING SHELVES

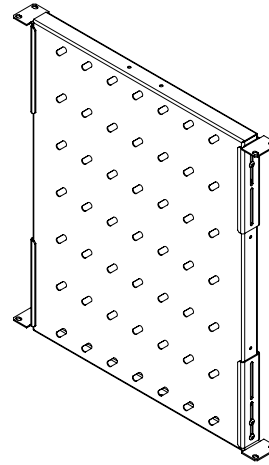
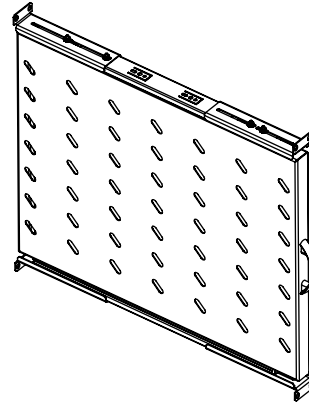

PRODUCT REFERENCE	DESCRIPTION
SHLFIX60M50	D= 600 mm fixed shelf module with slots, load capacity 50 kg., Ral9005, depth of the shelf D= 372 mm, 4-points fixed. Only suitable for 600 mm depth cabinets.
SHLFIX80M50	D= 800 mm fixed shelf module with slots, load capacity 50 kg., Ral9005, depth of the shelf D= 530 mm, 4-points fixed. Only suitable for 800 mm depth cabinets.
SHLFIX100M50	D= 1000 mm fixed shelf module with slots, load capacity 50 kg., Ral9005, depth of the shelf D= 696 mm, 4-points fixed. Only suitable for 1000 mm depth cabinets.
SHLSLD60M50	D= 600 mm sliding shelf module with slots, load capacity 30 kg., Ral9005, depth of the shelf D= 372 mm, 4-points fixed. Only suitable for 600 mm depth cabinets.
SHLSLD80M50	D= 800 mm sliding shelf module with slots, load capacity 30 kg., Ral9005, depth of the shelf D= 530 mm, 4-points fixed. Only suitable for 800 mm depth cabinets.
SHLSLD100M50	D= 1000 mm sliding shelf module with slots, load capacity 30 kg., Ral9005, depth of the shelf D= 696 mm, 4-points fixed. Only suitable for 1000 mm depth cabinets.

UniversalLine Accessories

FAN MODULE

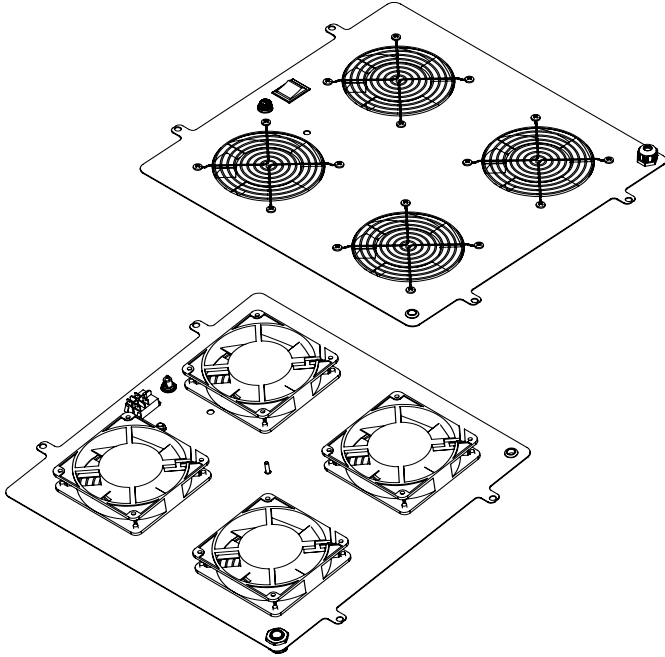

PRODUCT REFERENCE	DESCRIPTION
M44HV2FDT_01M50	Fan module, 2 fan + digital thermostat, 2P+E plug, schuko std., 2 pre-cut hole
M44HV2FDT_01M50_UK	Fan module, 2 fan + digital thermostat, 2P+E plug, UK std., 2 pre-cut hole
M44HV2FT_01M50	Fan module, 2 fan + analog thermostat, 2P+E plug, schuko std., 2 pre-cut hole
M44HV2FT_01M50_UK	Fan module, 2 fan + analog thermostat, 2P+E plug, UK std., 2 pre-cut hole
M44HV2F_01M50	Fan module, 2 fan + On/Off, 2P+E plug, schuko std., 2 pre-cut hole
M44HV2F_01M50_UK	Fan module, 2 fan + On/Off, 2P+E plug, UK std., 2 pre-cut hole
M44HV4FDT_01M50	Fan module, 4 fan + digital thermostat, 2P+E plug, schuko std., 4 pre-cut hole
M44HV4FDT_01M50_UK	Fan module, 4 fan + digital thermostat, 2P+E plug, UK std., 4 pre-cut hole
M44HV4FT_01M50	Fan module, 4 fan + analog thermostat, 2P+E plug, schuko std., 4 pre-cut hole
M44HV4FT_01M50_UK	Fan module, 4 fan + analog thermostat, 2P+E plug, UK std., 4 pre-cut hole
M44HV4F_01M50	Fan module, 4 fan + On/Off, 2P+E plug, schuko std., 4 pre-cut hole
M44HV4F_01M50_UK	Fan module, 4 fan + On/Off, 2P+E plug, UK std., 4 pre-cut hole

HORIZONTAL CABLE MANAGER

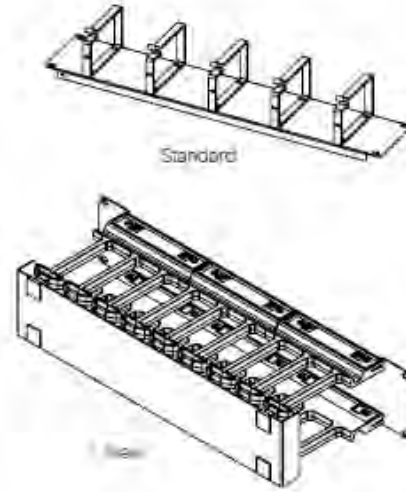

PRODUCT REFERENCE	DESCRIPTION	DIMENSIONS WxHxD (mm)
E44ORG1U_01M50	1U 19" cable management panels with 5 metal rings	483x44x80
E44ORG1UPLST_01M50	1U 19" cable management panels with 4 plastic rings	483x44x80
E44ORG1UN_01M50	1U 19" cable management panel, channel type and with removable cover	483x44x71
E44ORG2F_01M50	1U 19" cable management panels with front patch cord access holes, L shaped, rear tray for cable support	483x44x124
E44ORG2F_01M50BN	1U 19" cable management panels with front patch cord access holes, basic blank panel shaped	483x44x10
E44ORG2U_01M50	2U 19" cable management panels with 5 rings	483x88x76
E44ORG1F_01M50	1/2U 19" cable management panels with front patch cord access holes	483x22x100
E44ORG2UFT_01M50	2U 19", Cable Management Panels with 5 Metal Rings - Finger Type	483x88x166

VERTICAL CABLE MANAGER



PRODUCT REFERENCE	DESCRIPTION
M44ORG16_03M50	16U Vertical Cable Organizer
M44ORG20_03M50	20U Vertical Cable Organizer
M44ORG22_03M50	22U Vertical Cable Organizer
M44ORG26_03M50	26U Vertical Cable Organizer
M44ORG32_03M50	32U Vertical Cable Organizer
M44ORG36_03M50	36U Vertical Cable Organizer
M44ORG42_03M50	42U Vertical Cable Organizer
M44ORG45_03M50	45U Vertical Cable Organizer
M44ORG47_03M50	47U Vertical Cable Organizer

CABLE TRAY

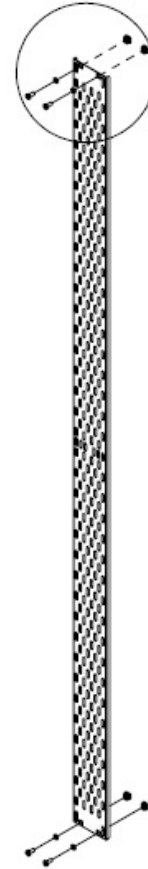

PRODUCT REFERENCE	DESCRIPTION
CT1610	Cable Tray, 16U, w= 100 mm
CT2010	Cable Tray, 20U, w= 100 mm
CT2210	Cable Tray, 22U, w= 100 mm
CT2610	Cable Tray, 26U, w= 100 mm
CT3210	Cable Tray, 32U, w= 100 mm
CT3610	Cable Tray, 36U, w= 100 mm
CT3910	Cable Tray, 39U, w= 100 mm
CT4210	Cable Tray, 42U, w= 100 mm
CT4510	Cable Tray, 45U, w= 100 mm
CT4710	Cable Tray, 47U, w= 100 mm

UniversalLine Accessories

BLANK PANELS

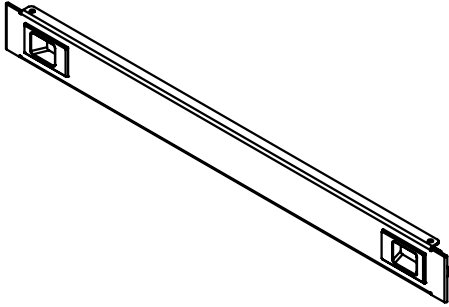

PRODUCT REFERENCE	DESCRIPTION	DIMENSIONS WxHxD (mm)
E44BPN01_0150M	1U 19" Blank panel	483x44x12
E44BPN02_0150M	2U 19" Blank panel	483x88x12
E44BPN03_0150M	3U 19" Blank panel	483x133x12
E44BPN04_0150M	4U 19" Blank panel	483x177x12
E44BPN05_0150M	5U 19" Blank panel	483x222x12
E44BPN06_0150M	6U 19" Blank panel	483x266x12
P44BPN06_01M50	6U 19" Modular plastic blank panel (ABS)	483x266x12

GROUNDING KIT

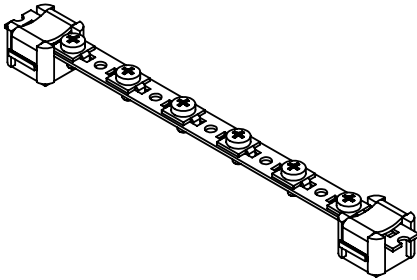

PRODUCT REFERENCE	DESCRIPTION
M44PEB01	Grounding kit, 6 each earthing leads + copper busbar
M44PEB19_01	Grounding kit, 13 each earthing leads + copper busbar

LED LIGHT

PRODUCT REFERENCE	DESCRIPTION	HxWxD (mm)
MAYDNLED-IRM	LED LIGHT	10X300X30

FLOOR FIXING KIT

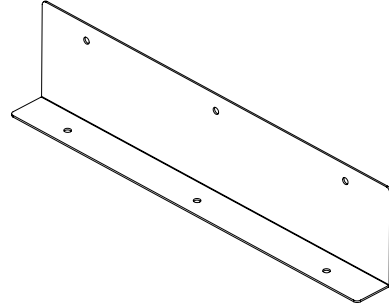

PRODUCT REFERENCE	DESCRIPTION
M44DPR01_01M50C	Floor fixing kit using cabinet with leveling feet
M44DPR01_01M50B	Floor fixing kit using cabinet with caster

BAYING KIT

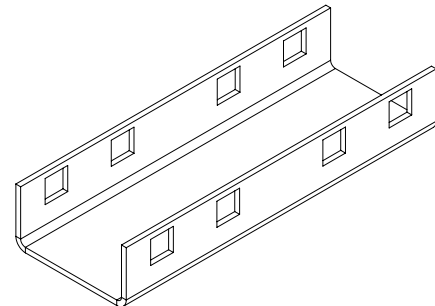

PRODUCT REFERENCE	DESCRIPTION
M44BLG01_01M50	Baying kit

FIXINGS

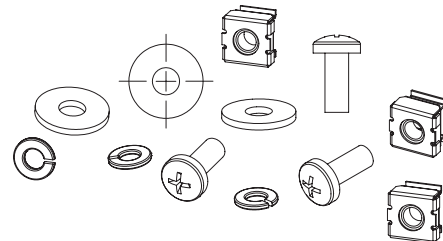

PRODUCT REFERENCE	DESCRIPTION
KFS6X15_20	M6 caged nut, screw, washer (1set=20ea)
KFS6X15_50	M6 caged nut, screw, washer (1set=50ea)

TECHNICAL CHARACTERISTICS

Shatterproof glass with left and right metal frame

GLASS

4 mm thickness full-length smoked, shatterproof, tempered, secure

FRONT DOOR CONSTRUCTION

Single door opening

Front door lock

HANDLE TYPE, SINGLE POINT LOCKING

Adhesive material

High density polyurethane DIN 53479, DIN 53505

HINGE SYSTEM

Spring loaded

DOOR OPENING ANGLE AND SWAPPING

125 degree, possible to swap one side to the other

SIDE PANEL

Solid metal, 1 mm left and right (2ea.)

SIDE PANEL CONSTRUCTION

Lockable, removable c/with slam latches and lock

SIDE PANEL LOCK

Barrel type lock unit, single point + Slam latch (2ea)

REAR DOOR

Solid metal, 1 mm

REAR DOOR CONSTRUCTION

Single opening, solid metal with brushed cable entry on top and bottom.

REAR DOOR LOCK

Barrel type lock unit, single point

HINGE SYSTEM

Spring loaded

DOOR OPENING ANGLE AND SWAPPING

125 degree, possible to swap one side to the other

TOP COVER

Solid metal 1 mm

TOP COVER CONSTRUCTION

Pagoda type structure provides efficient air removal

FRAMEWORK

TOP AND BOTTOM BASE UNITS

Solid metal 1,5 mm

TOP AND BOTTOM BASE UNITS CONSTRUCTION

Completely welded corner socket system

UPRIGHTS

Solid metal, 1,5 mm

UPRIGHTS CONSTRUCTION

Tightly fixed into top and bottom base units 6 times folded

INTERIOR PARTS

19" mounting angles

Solid metal, 1,5 mm

3 times folded 600x600, 600x780 / 1 time folded for 600x1000

"U" marking available 2 ea. at rear, 2 ea. at front

Pre-configured as 19"

Zinc plated, passivated, 8-12 micron.

Adjustable in depth

C TYPE SUPPORT RAILS IN DEPTH

Solid metal, 1,5 mm

3 times folded, 2 ea. at left , 2 ea. at right up

TESTS AND COMPLIED STANDARDS

TESTS AND COMPLIED STANDARDS

- 1) ISO 9001:2015 Quality Management System
- 2) ISO 14001:2015 Environmental Management System
- 3) ISO 27001:2013 Information Security Management System
- 4) ISO 45001:2018 Occupational Health and Safety Management System
- 5) 19" device mounting uprights IEC 297-1
- 6) EN 61587-1 Mechanical structures for electronic equipment.
- 7) All cabinet sizes complies with IEC 297-2.

RESISTANCE TO ENVIRONMENTAL CONDITIONS AND CORROSION;

STABILITY, MECHANICAL SAFETY, RESISTANCE TO STATIC, DYNAMIC AND MECHANICAL LOADS;

RESISTANCE TO VIBRATION, MECHANICAL SHOCK AND IMPACT;

DEGREES OF MECHANICAL PROTECTION PROVIDED BY THE ENCLOSURE (IP20);

ELECTRICAL GROUNDING CONTINUITY;

FIRE AND FLAME RESISTANCE;

Have been tested according to the standard " EN 61587-1" with the normative standards: IEC 60917, IEC 60297, IEC 60068-1, IEC 60068-2, IEC 60695-11-10, IEC 60950-1, contained and certified by the notified organizations::

TSE CERTIFICATE NO

003788-TSE-08/02

EAC CERTIFICATE NO

0443637, 0776963, 0345864, 0401678, 0776653

CORROSION

ISO 9227 Standard complied by the test report METALTEK AB-0547-T / 0157-1

TRANSPORT

ETS 300 019-1-2 Class 2.3 Comply with internal testing

STORAGE

ETS 300 019-1-1 Class 1.2 Comply with internal testing

SURFACE FINISH

Electrostatic powder coated c/with surface treatment , 80 +/- 5 micron paint thickness

PURCHASED PRODUCT CERTIFICATION

SHEET STEEL

EN 10346: 20015 DX51D+Z, EN 10130: 2006 DC01

ELECTROSTATIC POWDER COATING

ISO6860, ISO2409, ISO1520, ISO2815, ISO6272, ISO7253, ISO6270-1, ISO2812
ISO 9001, RoHS

GLASS

TS EN 12150-1, TS EN 1863-1

LOCK

IEC 62474, REACH, RoHS

CASTORS

ISO 9001, TS EN 12532, RoHS

FAN

IEC 60335-2-80:2002, IEC 60335-1:2010

Evoline

Intro

Evoline cabinets are suitable for offices, equipment rooms as server housing and infrastructural cabling installations.



GENERAL CHARACTERISTICS

- 4 mm thickness of glass, full-length smoked, shatterproof, tempered, secure
- Depth adjustable 19" mounting uprights even when the cabinet is fully loaded
- 1000 kg load carrying capacity
- Easy assembling flat pack option provides ease and 50% reduced volume for transportation
- Single handedly assembled in less than 20 minutes with basic standard tools
- 3 sides lockable & removable steel sheet panels
- Safety glass front door; metal and perforated options are available
- Wide range of sizes from 16U to 47U
- Depth sizes: 600 mm, 800 mm and 1000 mm
- Standard colors:
RAL 9005 Black & RAL 7035 Light Grey



Flexible and Cost-effective

Evoline 19" rack cabinets are ergonomic, powerful, flexible and cost-effective.

- 6 times bended frame units for increased stability
- Optional Pagoda style top cover increases protection against dust and other overhead leakage. Additionally, this style simulates a chimney effect for a convectional passive air flow
- Levelling feet are included as default. Alternatively compatible with casters
- Front door features a full length, smoked and shatterproof safety glass door with left and right metal frames and integral locking mechanism. The door hinge is easily swapped from one side to the other to change the direction that the door opens (single door option)
- Rear panel lockable and removable. Solid metal and perforated door options are available. Door hinges are easily swapped from one side to the other to change the direction that the door opens. Brushed cable entry on the top and/or bottom of rear door is available as an accessory
- Side Panels are lockable & removable steel sheet panels to complete the flexibility and 4-way easy access (front, rear and side panels) of the entire cabinet
- Multiple brushed cable entries on top and the bottom of the cabinet



Evoline

PRODUCT REFERENCE

W=600 MM CABINET DIMENSIONS (MM)

PRODUCT REFERENCE*	"U" HEIGHT	DEPTH OVERALL	DEPTH MAX MOUNTING PROFILE	HEIGHT VERTICAL MOUNTING PROFILE	HEIGHT WITHOUT LEVELLING FEET	HEIGHT WITH LEVELLING FEET MIN	HEIGHT WITH CASTERS
EVL16U6060...	16	600	460	750	816	841	896
EVL16U6080...	16	800	660	750	816	841	896
EVL20U6060...	20	600	460	919	994	1019	1074
EVL20U6080...	20	800	660	919	994	1019	1074
EVL22U6060...	22	600	460	1008	1083	1108	1163
EVL22U6080...	22	800	660	1008	1083	1108	1163
EVL26U6060...	26	600	460	1185	1260	1285	1340
EVL26U6080...	26	800	660	1185	1260	1285	1340
EVL26U6010...	26	1000	860	1185	1260	1285	1340
EVL32U6060...	32	600	460	1452	1527	1552	1607
EVL32U6080...	32	800	660	1452	1527	1552	1607
EVL32U6010...	32	1000	860	1452	1527	1552	1607
EVL36U6060...	36	600	460	1630	1705	1730	1785
EVL36U6080...	36	800	660	1630	1705	1730	1785
EVL36U6010...	36	1000	860	1630	1705	1730	1785
EVL39U6060...	39	600	460	1763	1838	1863	1918
EVL39U6080...	39	800	660	1763	1838	1863	1918
EVL39U6010...	39	1000	860	1763	1838	1863	1918
EVL42U6060...	42	600	460	1897	1972	1997	2052
EVL42U6080...	42	800	660	1897	1972	1997	2052
EVL42U6010...	42	1000	860	1897	1972	1997	2052
EVL45U6060...	45	600	460	1991	2065	2090	2145
EVL45U6080...	45	800	660	1991	2065	2090	2145
EVL45U6010...	45	1000	860	1991	2065	2090	2145
EVL47U6060...	47	600	460	2119	2194	2219	2274
EVL47U6080...	47	800	660	2119	2194	2219	2274
EVL47U6010...	47	1000	860	2119	2194	2219	2274

* Pls complete the reference code referring the "Reference Code Creation" on next pages.

PRODUCT REFERENCE

W=800 MM CABINET DIMENSIONS (MM)

PRODUCT REFERENCE*	"U" HEIGHT	DEPTH OVERALL	DEPTH MAX MOUNTING PROFILE	HEIGHT VERTICAL MOUNTING PROFILE	HEIGHT WITHOUT LEVELLING FEET	HEIGHT WITH LEVELLING FEET MIN	HEIGHT WITH CASTERS
EVL16U8060...	16	600	460	750	816	841	896
EVL16U8080...	16	800	660	750	816	841	896
EVL20U8060...	20	600	460	919	994	1019	1074
EVL20U8080...	20	800	660	919	994	1019	1074
EVL22U8060...	22	600	460	1008	1083	1108	1163
EVL22U8080...	22	800	660	1008	1083	1108	1163
EVL26U8060...	26	600	460	1185	1260	1285	1340
EVL26U8080...	26	800	660	1185	1260	1285	1340
EVL32U8060...	32	600	460	1452	1527	1552	1607
EVL32U8080...	32	800	660	1452	1527	1552	1607
EVL32U8010...	32	1000	860	1452	1527	1552	1607
EVL36U8060...	36	600	460	1630	1705	1730	1785
EVL36U8080...	36	800	660	1630	1705	1730	1785
EVL36U8010...	36	1000	860	1630	1705	1730	1785
EVL39U8060...	39	600	460	1763	1838	1863	1918
EVL39U8080...	39	800	660	1763	1838	1863	1918
EVL39U8010...	39	1000	860	1763	1838	1863	1918
EVL42U8060...	42	600	460	1897	1972	1997	2052
EVL42U8080...	42	800	660	1897	1972	1997	2052
EVL42U8010...	42	1000	860	1897	1972	1997	2052
EVL45U8060...	45	600	460	1991	2065	2090	2145
EVL45U8080...	45	800	660	1991	2065	2090	2145
EVL45U8010...	45	1000	860	1991	2065	2090	2145
EVL47U8060...	47	600	460	2119	2194	2219	2274
EVL47U8080...	47	800	660	2119	2194	2219	2274
EVL47U8010...	47	1000	860	2119	2194	2219	2274

* Pls complete the reference code referring the "Reference Code Creation" on next pages.

Evoline

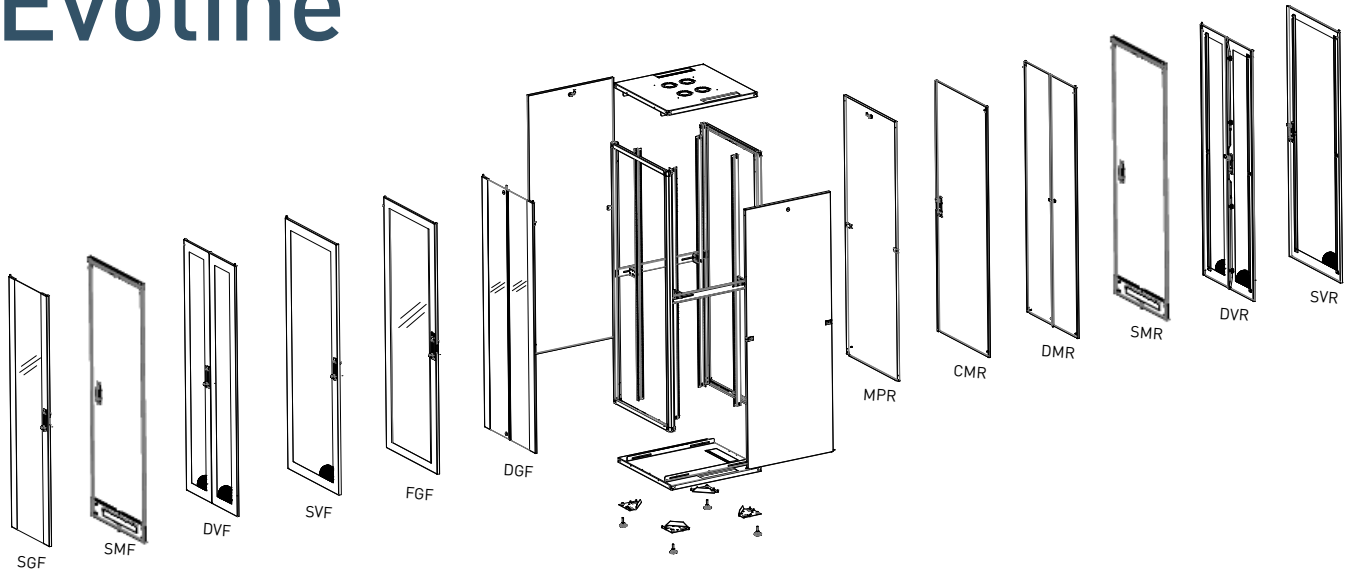

DOOR SELECTION TABLE AND REFERENCE CODE CREATION

DOOR CODE	DESCRIPTION	EVL W= 600 MM	EVL W= 800 MM
FRONT			
SGF	Single Glass Front Door, single point locking	Standard	
DGF	Double Glass Front Door, two point barrel locking		Standard
FGF	Single, Full Frame Glass Front Door, single point locking	Optional	Optional
SVF	Single Vented Front Door, 63% perforated, single point locking	Optional	Optional
DVF	Double Vented Front Door, 63% perforated, three point locking	Optional	Optional
SMF	Solid Metal Front Door	Optional	Optional
REAR			
MPR	Solid Metal Panel Rear	Standard	Standard
CMR	Single Solid Metal Rear Door	Optional	Optional
DMR	Double Solid Metal Rear Door with cable entries on top and bottom		Optional
SVR	Single Vented Rear Door, 63% perforated, single point locking	Optional	Optional
DVR	Double Vented Rear Door, 63% perforated, three point locking		Optional
SMR	Solid Metal Rear Door(s) with cable entries on top & bottom	Optional	Optional

REFERENCE CODE CREATION

Marked are also Default Config.

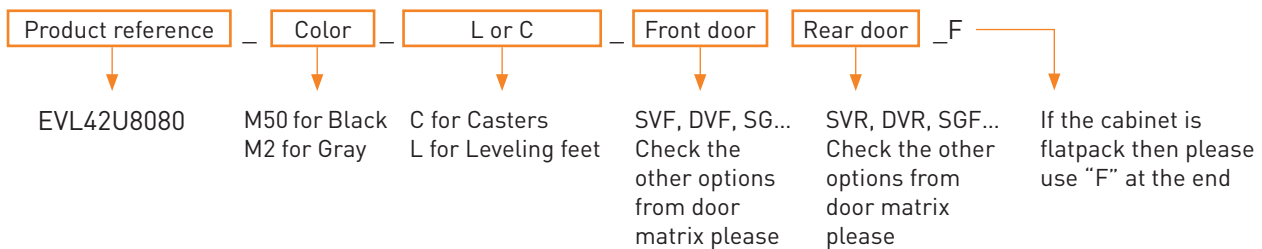

Example:

EVL42U8080_M50_L_SVFDVR → for a mounted cabinet

EVL42U8080_M50_L_SVFDVR_F → for a flatpack cabinet

TECHNICAL DRAWINGS W=600 mm CABINETS

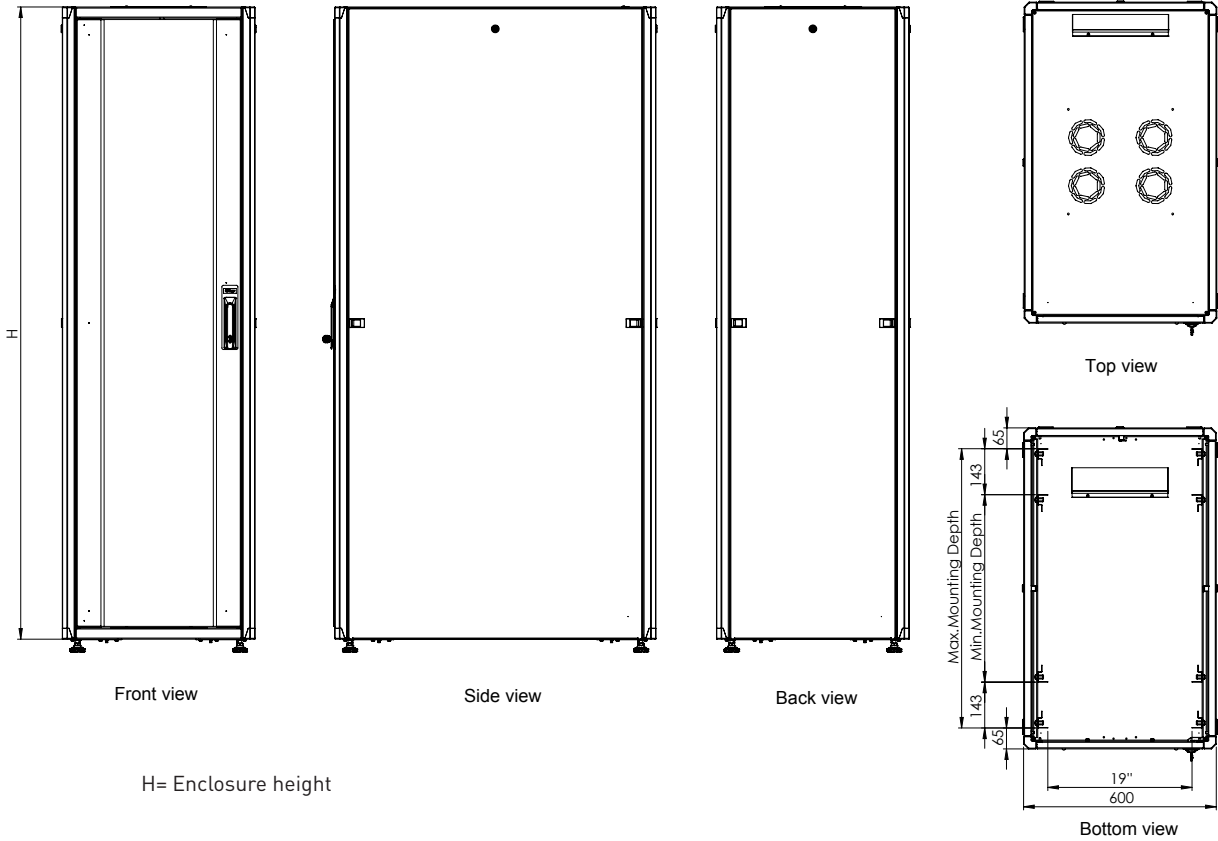

H= Enclosure height

W=800 mm CABINETS

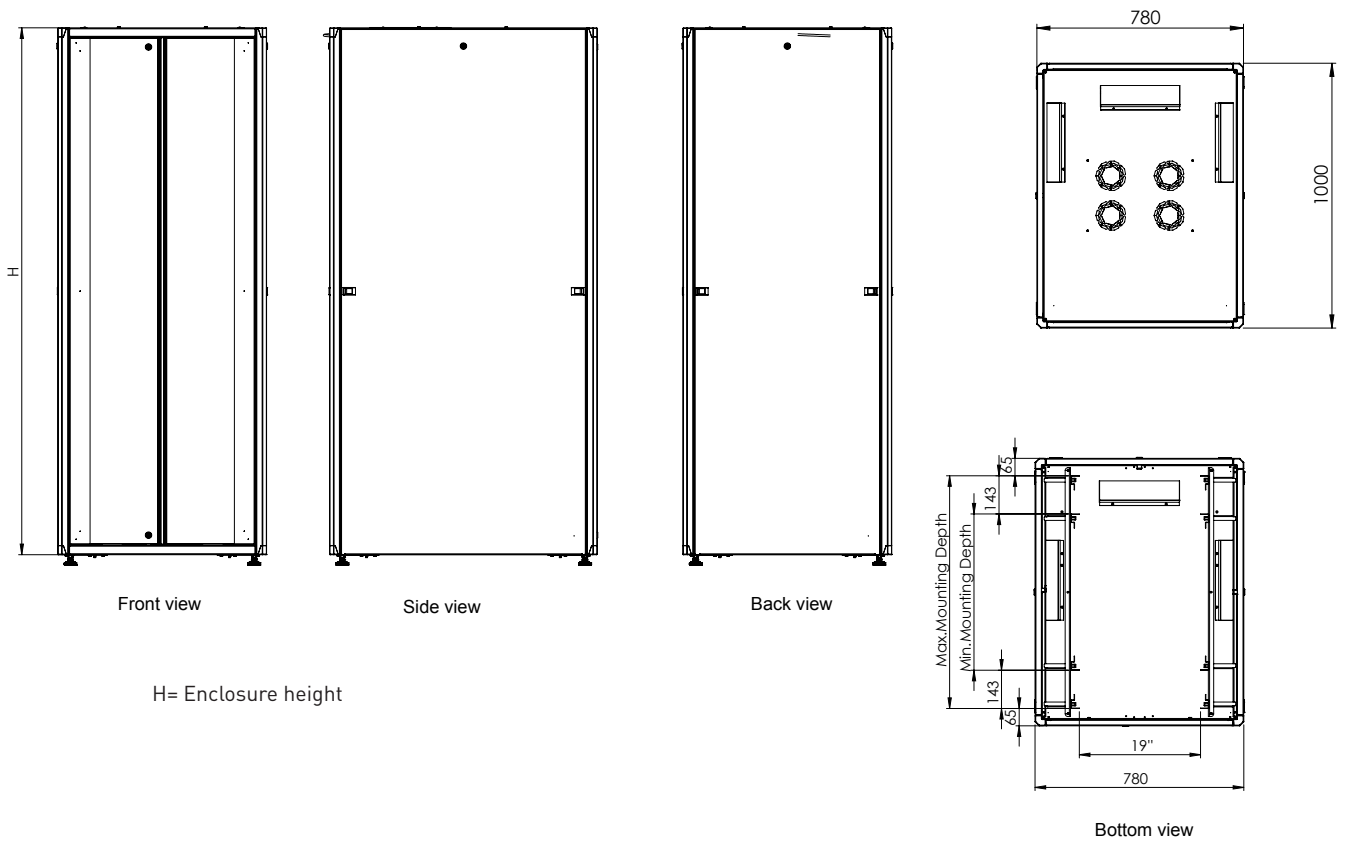

H= Enclosure height

19" FREE-STANDING RACK CABINETS



FLOOR FIXING KIT

Perfect design! No extension beyond the bottom area of the cabinet 4-points fixing between the cabinet and the floor - front/rear, right/left. Galvanised sheet metal.

FAN MODULE

2 or 4 pcs. of fan on a module, with ON/OFF, analog or digital thermostat functions. Complete inner wiring. 1U

CASTER AND LEVELLING FEET

Rotational type casters, 2 pieces front have lockable function
Levelling feet: Height adjustment from the floor 250 kg. load carrying capacity of each wheel and each levelling feet.

LED LIGHT

Effective and powerful lighting.
Different dimensions 19", 1U, with ON/OFF switch, automatic door with ON/OFF switch or LED with sensor.

GROUNDING CONTINUITY

Grounding cables for all metal components. Cable connections with bolts and nuts for all doors.

Evoline Accessories

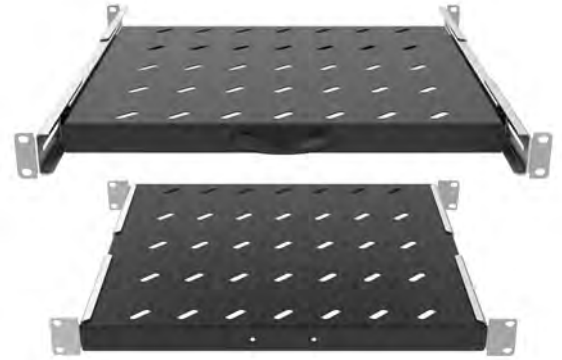

CABLE TRAY

Options from 16U to 47U. The galvanized coating must be perforated to provide length and cable installation along the height of the cabinet.
Unified cable tray for every cabinet range.

FIXED AND SLIDING SHELF

Fixing points at the sides of rear and front 19" uprights.
Vented for air circulation, adjustable depth, sheet steel material. Available for all kind of cabinet depths like 600mm, 800mm and 1000mm.

BRUSHED CABLE ENTRY *

2 pieces of 50x300 mm cable entries on the top and bottom chassis, 1 piece of 80x300 mm for the bottom chassis.

VERTICAL CABLE ORGANIZER

Options from 16U to 47U.
Large internal volume that protects all kind of electric and data cables and patch cords.
It attaches to the sides along 19" uprights and have cable entry holes.



* The image is for the width of 800 mm cabinet

Evoline Accessories

TOP COVER

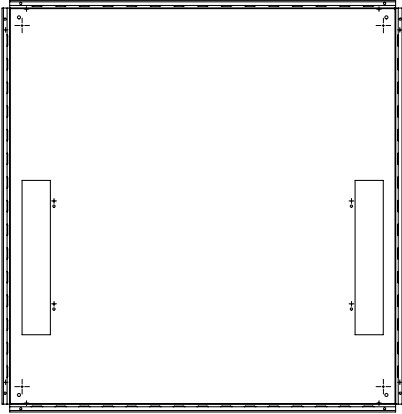

PRODUCT REFERENCE	DESCRIPTION
EVL794M66L00M50	Top cover , Width=600 mm / depth=600 mm
EVL794M68L00M50	Top cover , Width=600 mm / depth=800 mm
EVL794M61L00M50	Top cover , Width=600 mm / depth=1000 mm
EVL794M86L00M50	Top cover , Width=780 mm / depth=600 mm
EVL794M88L00M50	Top cover , Width=780 mm / depth=800 mm
EVL794M81L00M50	Top cover , Width=780 mm / depth=1000 mm

PLINTH

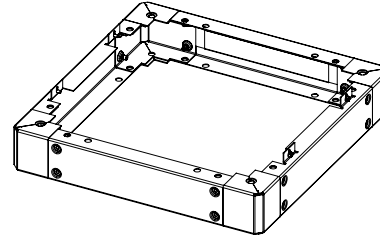

WITH CABLE ENTRY

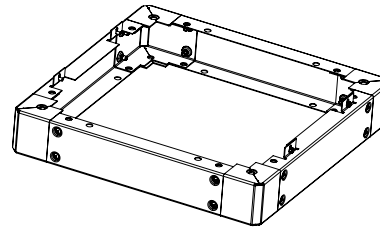

WITHOUT CABLE ENTRY

WITH CABLE ENTRY STOCK NO	A (mm)	B (mm)	C (mm)	D (mm)	E (mm)
EVL795M66L00M50	600	600	100	506.40	506.40
EVL795M68L00M50	600	800	100	506.40	706.40
EVL795M61L00M50	600	1000	100	506.40	906.40
EVL795M86L00M50	780	600	100	686.40	506.40
EVL795M88L00M50	780	800	100	686.40	706.40
EVL795M81L00M50	780	1000	100	686.40	906.40
WITHOUT CABLE ENTRY STOCK NO					
EVL795M66L01M50	600	600	100	506.40	506.40
EVL795M68L01M50	600	800	100	506.40	706.40
EVL795M61L01M50	600	1000	100	506.40	906.40
EVL795M86L01M50	780	600	100	686.40	506.40
EVL795M88L01M50	780	800	100	686.40	706.40
EVL795M81L01M50	780	1000	100	686.40	906.40

CASTER AND LEVELLING FEET

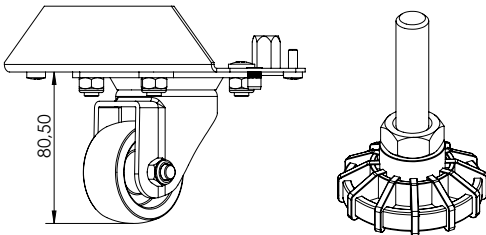

PRODUCT REFERENCE	DESCRIPTION
CST	Casters, 2 pcs. front are lockable
M11PNY02	Levelling feet (1 set = 4 pcs.)

HEAVY DUTY TYPE SHELF

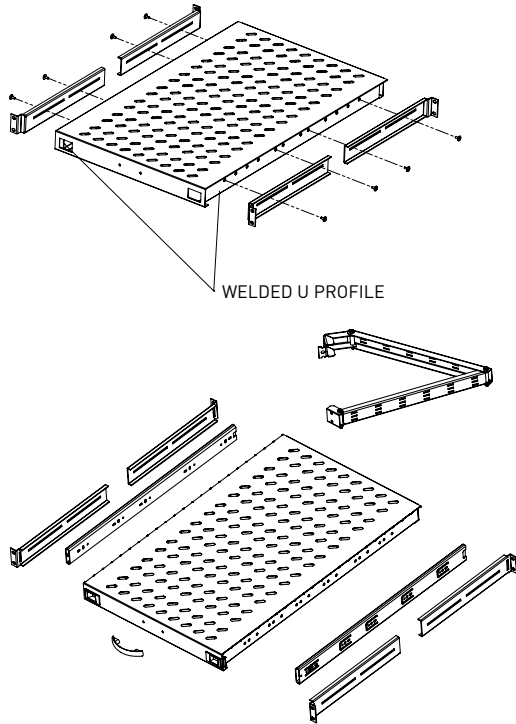

PRODUCT REFERENCE	DESCRIPTION	HxWxD (mm)
M55SR720_01M50	19", heavy duty fixed shelf, adjustable in depth	50x483x720
M55HR720_01M50	19", heavy duty sliding shelf, adjustable in depth, vented, complete with rear cable management system	50x483x720

19" KEYBOARD DRAWER

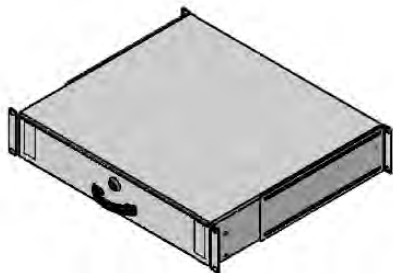

PRODUCT REFERENCE	DESCRIPTION	DIMENSIONS WxHxD (mm)
M44CEK2U_01M50	2U 19" drawer, lockable suitable up to depth=800mm. Cabinets, for D=1000 mm cabinet usage extra brackets available in package, sheet steel material and load carrying capacity is 25 kg.	483x88x400
M44CEK3U_01M50	3U 19" drawer, lockable suitable up to depth=800mm. Cabinets, for D=1000 mm cabinet usage extra brackets available in package, sheet steel material and load carrying capacity is 25 kg.	483x133x400

FIXED AND SLIDING SHELVES

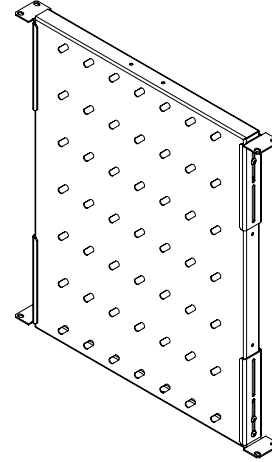
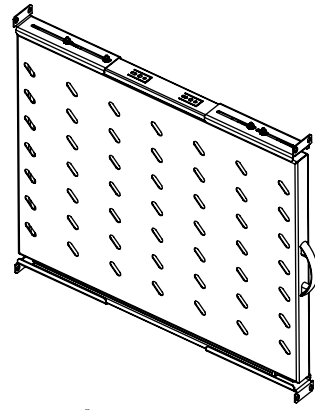

PRODUCT REFERENCE	DESCRIPTION
SHLFIX60M50	D= 600 mm fixed shelf module with slots, load capacity 50 kg., Ral9005, depth of the shelf D= 372 mm, 4-points fixed. Only suitable for 600 mm depth cabinets.
SHLFIX80M50	D= 800 mm fixed shelf module with slots, load capacity 50 kg., Ral9005, depth of the shelf D= 530 mm, 4-points fixed. Only suitable for 800 mm depth cabinets.
SHLFIX100M50	D= 1000 mm fixed shelf module with slots, load capacity 50 kg., Ral9005, depth of the shelf D= 696 mm, 4-points fixed. Only suitable for 1000 mm depth cabinets.
SHLSLD60M50	D= 600 mm sliding shelf module with slots, load capacity 30 kg., Ral9005, depth of the shelf D= 372 mm, 4-points fixed. Only suitable for 600 mm depth cabinets.
SHLSLD80M50	D= 800 mm sliding shelf module with slots, load capacity 30 kg., Ral9005, depth of the shelf D= 530 mm, 4-points fixed. Only suitable for 800 mm depth cabinets.
SHLSLD100M50	D= 1000 mm sliding shelf module with slots, load capacity 30 kg., Ral9005, depth of the shelf D= 696 mm, 4-points fixed. Only suitable for 1000 mm depth cabinets.

Note: Color code "M50" is RAL 9005 black, "M2" RAL 7035 light grey option is available

Evoline Accessories

FAN MODULE

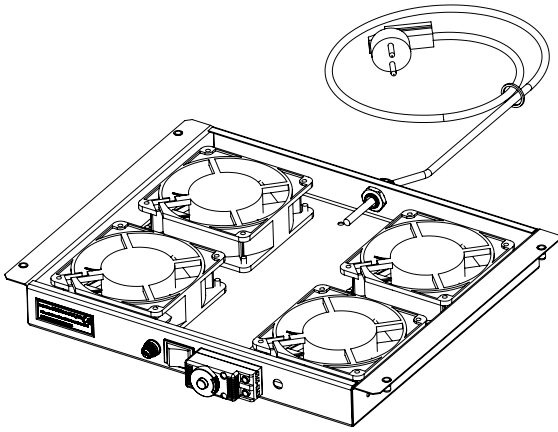

PRODUCT REFERENCE	DESCRIPTION
FAN4AT4F01_M50	Fan module, 4 fan + analog thermostat, 2P+E plug, schuko std.
FAN4AT2F01_M50	Fan module, 2 fan + analog thermostat, 2P+E plug, schuko std.
FAN4AT4F02_M50	Fan module, 4 fan + analog thermostat, 2P+E plug, UK std.
FAN4AT2F02_M50	Fan module, 2 fan + analog thermostat, 2P+E plug, UK std.
FAN4DT4F01_M50	Fan module, 4 fan + digital thermostat, 2P+E plug, schuko std.
FAN6DT6F01_M50	Fan module for 1000 depth cabinets, 6 fan + digital thermostat, 2P+E plug, schuko std., 6 pre-cut hole
FAN6DT6F02_M50	Fan module for 1000 depth cabinets, 6 fan + digital thermostat, 2P+E plug, UK std., 6 pre-cut hole
FAN6OO6F01_M50	Fan module for 1000 depth cabinets, 6 fan + On/Off, 2P+E plug, schuko std., 6 pre-cut hole
FAN6OO6F02_M50	Fan module for 1000 depth cabinets, 6 fan + On/Off, 2P+E plug, UK std., 6 pre-cut hole
FAN6AT6F01_M50	Fan module for 1000 depth cabinets, 6 fan + analog thermostat, 2P+E plug, schuko std., 6 pre-cut hole
FAN6AT6F02_M50	Fan module for 1000 depth cabinets, 6 fan + analog thermostat, 2P+E plug, UK std., 6 pre-cut hole

BLANK PANELS

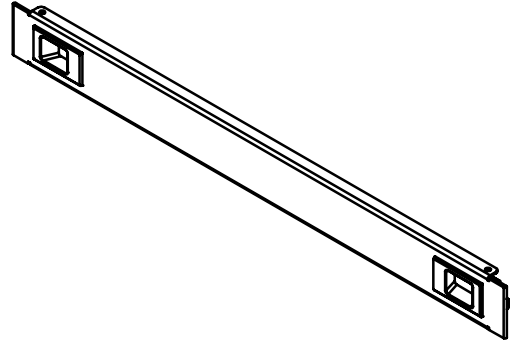

PRODUCT REFERENCE	DESCRIPTION	DIMENSIONS WxHxD (mm)
E44BPN01_0150M	1U 19" Blank panel	483x44x12
E44BPN02_0150M	2U 19" Blank panel	483x88x12
E44BPN03_0150M	3U 19" Blank panel	483x133x12
E44BPN04_0150M	4U 19" Blank panel	483x177x12
E44BPN05_0150M	5U 19" Blank panel	483x222x12
E44BPN06_0150M	6U 19" Blank panel	483x266x12
P44BPN06_01M50	6U 19" Modular plastic blank panel (ABS)	483x266x12

Note: Color code "M50" is RAL 9005 black, "M2" RAL 7035 light grey option is available

HORIZONTAL CABLE MANAGER

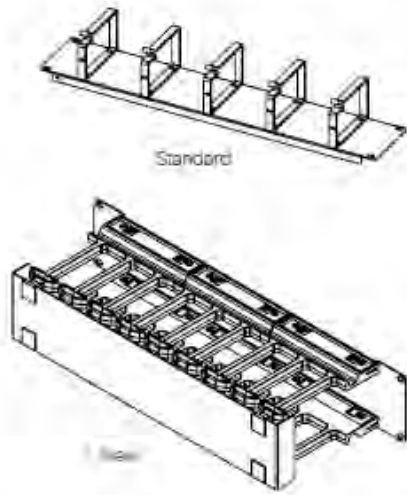

PRODUCT REFERENCE	DESCRIPTION	DIMENSIONS WxHxD (mm)
E440RG1U_01M50	1U 19" cable management panels with 5 metal rings	483x44x80
E440RG1UPLST_01M50	1U 19" cable management panels with 4 plastic rings	483x44x80
E440RG1UN_01M50	1U 19" cable management panel, channel type and with removable cover	483x44x71
E440RG2F_01M50	1U 19" cable management panels with front patch cord access holes, L shaped, rear tray for cable support	483x44x124
E440RG2F_01M50BN	1U 19" cable management panels with front patch cord access holes, basic blank panel shaped	483x44x10
E440RG2U_01M50	2U 19" cable management panels with 5 rings	483x88x76
E440RG1F_01M50	1/2U 19" cable management panels with front patch cord access holes	483x22x100
E440RG2UFT_01M50	2U 19", Cable Management Panels with 5 Metal Rings - Finger Type	483x88x166

VERTICAL CABLE MANAGER



PRODUCT REFERENCE	DESCRIPTION
M440RG16_03M50	16U Vertical Cable Organizer
M440RG20_03M50	20U Vertical Cable Organizer
M440RG22_03M50	22U Vertical Cable Organizer
M440RG26_03M50	26U Vertical Cable Organizer
M440RG32_03M50	32U Vertical Cable Organizer
M440RG36_03M50	36U Vertical Cable Organizer
M440RG42_03M50	42U Vertical Cable Organizer
M440RG45_03M50	45U Vertical Cable Organizer
M440RG47_03M50	47U Vertical Cable Organizer

Evoline Accessories

CABLE TRAY

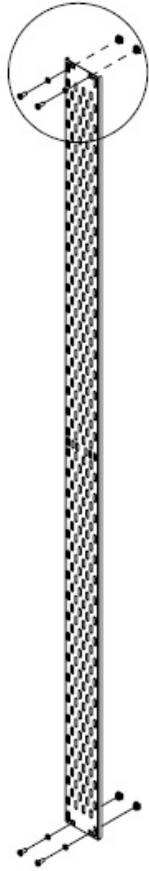

PRODUCT REFERENCE	DESCRIPTION
CT1210	Cable Tray, 12U, w= 100 mm
CT1610	Cable Tray, 16U, w= 100 mm
CT2010	Cable Tray, 20U, w= 100 mm
CT2210	Cable Tray, 22U, w= 100 mm
CT2610	Cable Tray, 26U, w= 100 mm
CT3210	Cable Tray, 32U, w= 100 mm
CT3610	Cable Tray, 36U, w= 100 mm
CT3910	Cable Tray, 39U, w= 100 mm
CT4210	Cable Tray, 42U, w= 100 mm
CT4510	Cable Tray, 45U, w= 100 mm
CT4710	Cable Tray, 47U, w= 100 mm

GROUNDING KIT

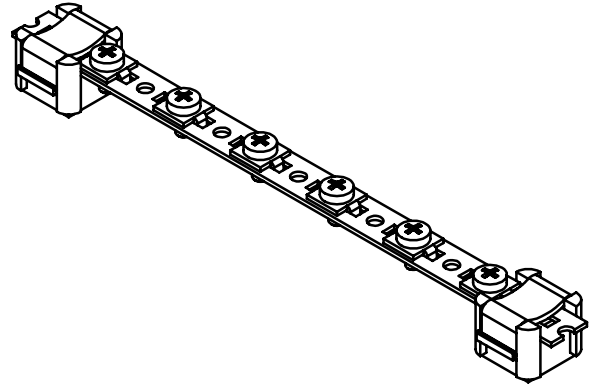

PRODUCT REFERENCE	DESCRIPTION
M44PEB01	Grounding kit, 6 each earthing leads + copper busbar
M44PEB19_01	Grounding kit, 13 each earthing leads + copper busbar

FLOOR FIXING KIT

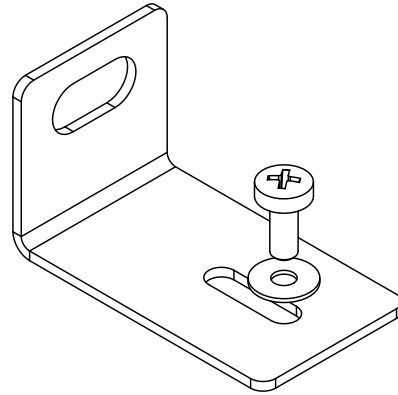

PRODUCT REFERENCE	DESCRIPTION
EVL792M02L00	Floor Fixing kit

BAYING KIT

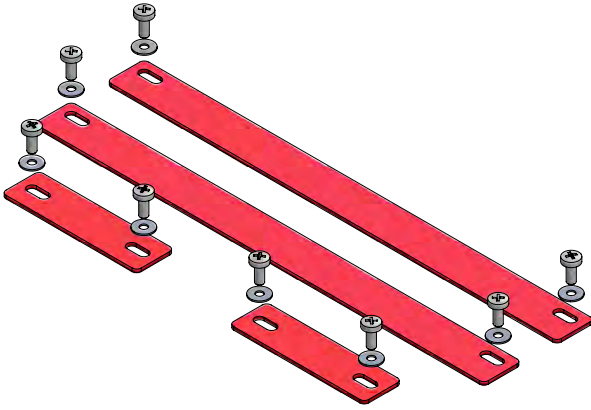

PRODUCT REFERENCE	DESCRIPTION
EVL792M01L00M50	Baying kit

FIXINGS

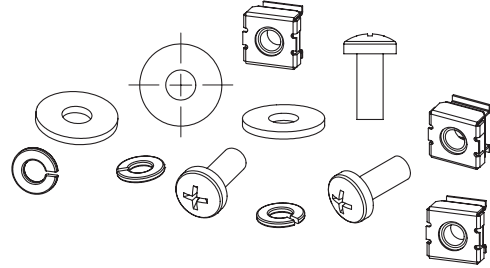

PRODUCT REFERENCE	DESCRIPTION
KFS6X15_20	M6 caged nut, screw, washer (1set=20ea)
KFS6X15_50	M6 caged nut, screw, washer (1set=50ea)

LED LIGHT

PRODUCT REFERENCE	DESCRIPTION	HxWxD (mm)
MAYDNLED-IRM	LED LIGHT	10X300X30

Evoline

TECHNICAL CHARACTERICS

INDEX OF PROTECTION

- IP20 according to EN61587-1, IEC60529
IP20: Protected against solid objects larger than 12,5 mm in diameter

MECHANICAL PERFORMANCE

- Load carrying capacity: 1000 kg.

DESIGN

- 1) Frame Units are 6 times bended and tightly fixed into top and bottom chassis
- 2) Mounting uprights, top and bottom base units are 1.5 mm thick sheet steel
- 3) Top and bottom chassis units construction are completely modular structures
- 4) Side panels made of 1,0 mm thick sheet steel
- 5) Front door, shatterproof glass with left and right frame
- 6) 115° front door opening angle

CORROSION RESISTANCE

- ISO 9227 and ASTM B 117-85, IEC60917 and IEC60297

SURFACE COATING

- 1) Electrostatic powder coated with surface treatment; 60-120 micron paint thickness
- 2) Comply with ISO 9001, ISO 2178, ISO 2813, ISO 6272, ISO 8130-5, ISO 8130-3, RoHS standards.

PURCHASED PRODUCT CERTIFICATION

SHEET STEEL

EN 10346: 20015 DX51D+Z, EN 10130: 2006 DC01

ELECTROSTATIC POWDER COATING

ISO6860, ISO2409, ISO1520, ISO2815, ISO6272, ISO7253, ISO6270-1, ISO2812

ISO 9001, RoHS

GLASS

TS EN 12150-1, TS EN 1863-1

LOCK

IEC 62474, REACH, RoHS

CASTORS

ISO 9001, TS EN 12532, RoHS

FAN

IEC 60335-2-80:2002, IEC 60335-1:2010

TESTS AND COMPLIED STANDARDS

TESTS AND COMPLIED STANDARDS

- 1) ISO 9001:2015 Quality Management System
- 2) ISO 14001:2015 Environmental Management System
- 3) ISO 27001:2013 Information Security Management System
- 4) ISO 45001:2018 Occupational Health and Safety Management System
- 5) 19" device mounting uprights IEC 297-1
- 6) EN 61587-1 Mechanical structures for electronic equipment.
- 7) All cabinet sizes complies with IEC 297-2.

RESISTANCE TO ENVIRONMENTAL CONDITIONS AND CORROSION; STABILITY, MECHANICAL SAFETY, RESISTANCE TO STATIC, DYNAMIC AND MECHANICAL LOADS;

RESISTANCE TO VIBRATION, MECHANICAL SHOCK AND IMPACT; DEGREES OF MECHANICAL PROTECTION PROVIDED BY THE ENCLOSURE (IP20);

ELECTRICAL GROUNDING CONTINUITY;

FIRE AND FLAME RESISTANCE;

Have been tested according to the standard " EN 61587-1" with the normative standards: IEC 60917, IEC 60297, IEC 60068-1, IEC 60068-2, IEC 60695-11-10, IEC 60950-1, contained and certified by the notified organizations::

TSE CERTIFICATE NO

003788-TSE-08/02

EAC CERTIFICATE NO

0443637, 0776963, 0345864, 0401678, 0776653

CORROSION

ISO 9227 Standard complied by the test report METALTEK AB-0547-T / 0157-1

TRANSPORT

ETS 300 019-1-2 Class 2.3 Comply with internal testing

STORAGE

ETS 300 019-1-1 Class 1.2 Comply with internal testing

SURFACE FINISH

Electrostatic powder coated c/with surface treatment , 80 +/- 5 micron paint thickness



RelayRack

Intro

Open frame/RelayRack offers highly cost-effective and easy assembly solutions for numerous applications in the field of network technology and electronics.



GENERAL CHARACTERISTICS

- Designed to house 19" standard mounting devices
- 300 kg load carrying capacity
- Wide range of sizes;
16U/22U/26U/36U/42U/48U
- Width: 536 mm
- Single frame for just 19" frontal assembly
- Single frame depth is 640 mm
- Double frame with 180 mm extension unit,
Depth= 820 mm
- Double frame with 300 mm extension unit,
Depth=940 mm
- Standard colors:
RAL 9005 Black & RAL 7035 Light Grey
- Uprights are punched in full-length with square holes to use standard accessory cable ring for cable management
- Levelling feet as standard
- Provides quick access to equipment
- Available as flatpack



Smart Design Options

Smart design features to be used as single frame or double frame.

- Single frame unit, provides housing for just 19" frontal assembly installations, compatible with all standard 19" frontal assembly accessories
- Double frame units, with extension unit in between the base structure of the Relayrack / Open Frames D=180mm, frame units will provide 4 point assembly possibility to house all D=800mm range accessories. where the frame base depth becomes 820 mm
- Double frame units, with extension unit in between the base structure of the Relayrack / Open Frames, D=300 mm frame units will provide 4 point assembly possibility to house all suitable range accessories, where the frame base depth becomes 940 mm, the application field is called servering; the Relayrack / Open Frames with this structure becomes server Relayrack



RelayRack

SINGLE FRAME

PRODUCT REFERENCE

D=640 MM CABINET DIMENSIONS (MM)

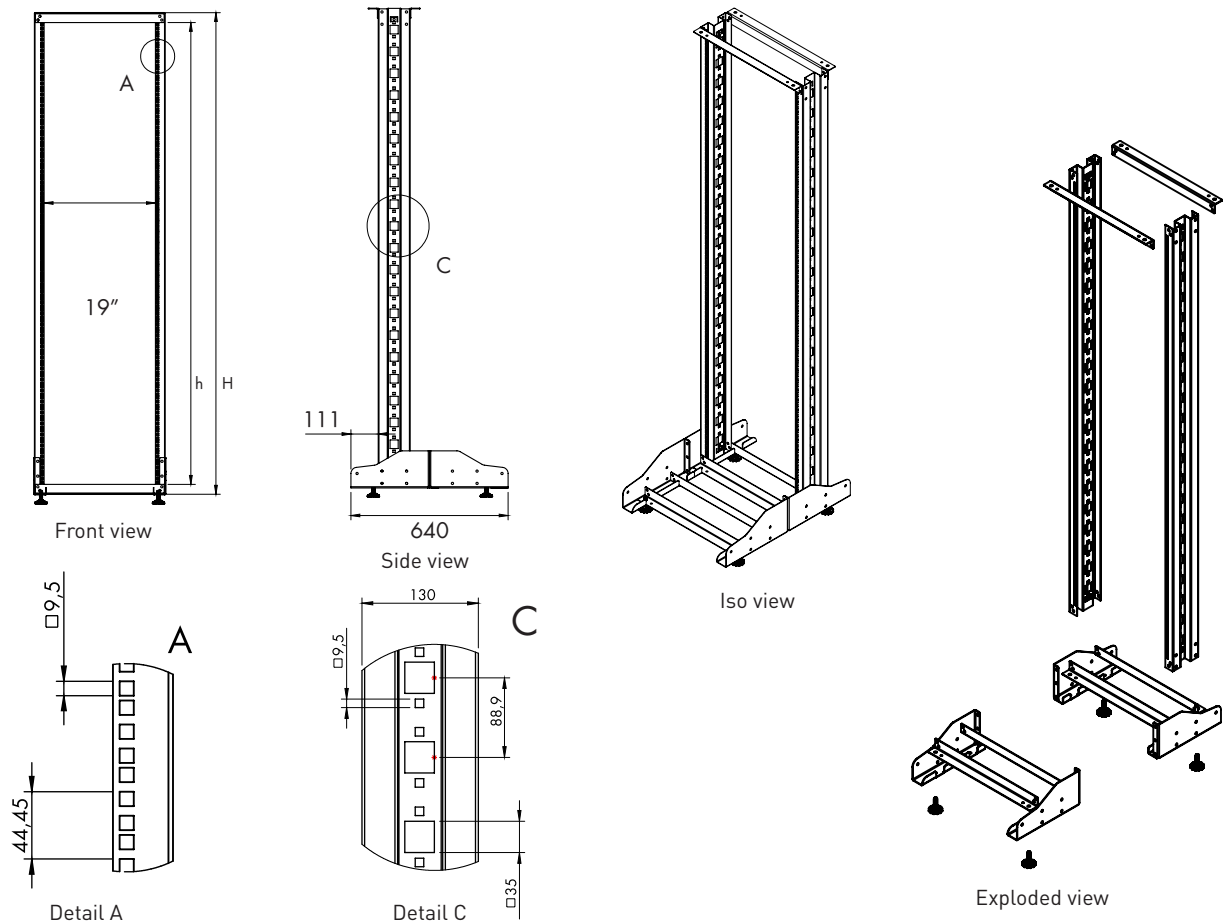

H= Enclosure height

PRODUCT REFERENCE	DESCRIPTION	DIMENSIONS WxDxH (mm)	INSIDE HEIGHT (mm)
MLRCK16S_01M50	16U 19" D=640 single frame	536x640x826	714,4
MLRCK22S_01M50	22U 19" D=640 single frame	536x640x1092	981,1
MLRCK26S_01M50	26U 19" D=640 single frame	536x640x1270	1158,9
MLRCK36S_01M50	36U 19" D=640 single frame	536x640x1715	1603,4
MLRCK42S_01M50	42U 19" D=640 single frame	536x640x1981	1870,1
MLRCK48S_01M50	48U 19" D=640 single frame	536x640x2248	2136,8

Note: Color code "M50" is RAL 9005 black, "M2" RAL 7035 light grey option is available

DOUBLE FRAME

PRODUCT REFERENCE

D=820 MM CABINET DIMENSIONS (MM)

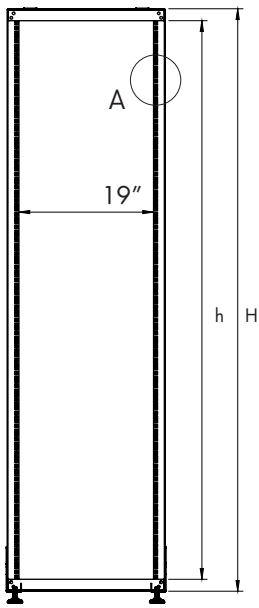

Front view

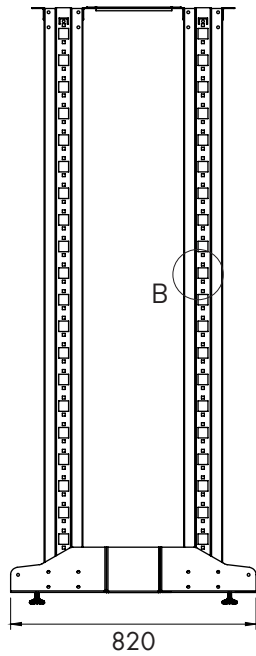

Side view

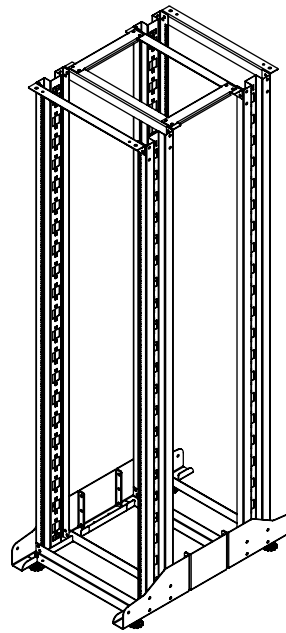

Iso view

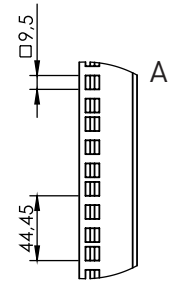

Detail A

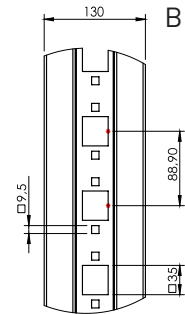

Detail B

PRODUCT REFERENCE	DESCRIPTION	DIMENSIONS WxDxH (mm)	INSIDE HEIGHT (mm)
MLRCK16D_01M50	16U 19" D= 820 double frame	536x820x826	714,4
MLRCK22D_01M50	22U 19" D= 820 double frame	536x820x1092	981,1
MLRCK26D_01M50	26U 19" D= 820 double frame	536x820x1270	1158,9
MLRCK36D_01M50	36U 19" D= 820 double frame	536x820x1715	1603,4
MLRCK42D_01M50	42U 19" D= 820 double frame	536x820x1981	1870,1
MLRCK48D_01M50	48U 19" D= 820 double frame	536x820x2248	2136,8
TOPCOVER66_01M50	Top cover	Width= 530 mm - Depth= 530 mm	-
TOPCOVER88_01M50	Top cover	Width= 530 mm - Depth= 730 mm	-

Note: Color code "M50" is RAL 9005 black, "M2" RAL 7035 light grey option is available

RelayRack

DOUBLE FRAME

PRODUCT REFERENCE

D=940 MM CABINET DIMENSIONS (MM)

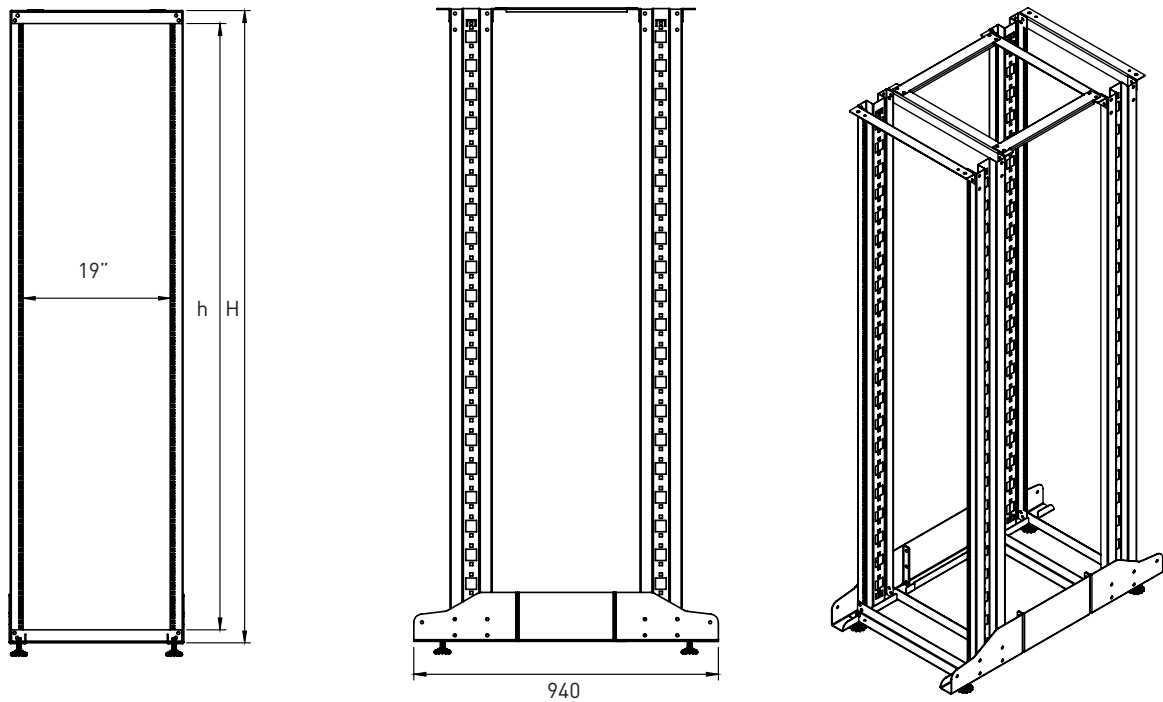

PRODUCT REFERENCE	DEFINITION	DIMENSIONS WxDxH (mm)	INSIDE HEIGHT (mm)
MLRCK26UD100_01M50	26U 19" D= 940 double frame	536x940x1270	1158,9
MLRCK36UD100_01M50	36U 19" D= 940 double frame	536x940x1715	1603,4
MLRCK42UD100_01M50	42U 19" D= 940 double frame	536x940x1981	1870,1
MLRCK48UD100_01M50	48U 19" D= 940 double frame	536x940x2248	2136,8
TOPCOVER100_01M50	Top cover	Width= 530 mm - Depth= 850 mm	-
TOPCOVER88_01M50	Top cover	Width= 530 mm - Depth= 730 mm	-

Note: Color code "M50" is RAL 9005 black, "M2" RAL 7035 light grey option is available

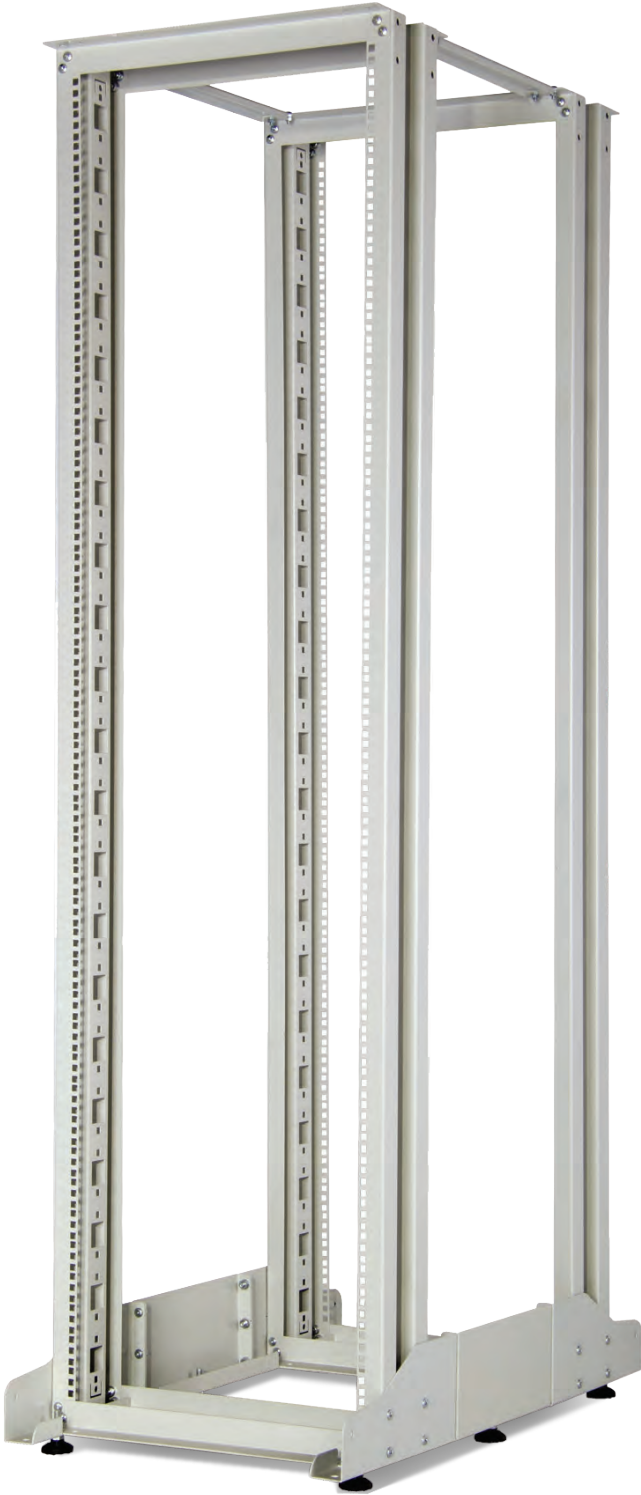

DOUBLE FRAME



SINGLE FRAME

RelayRack

NETWORK APPLICATIONS



AVAILABLE WITH HARD TOP

D=180 mm extension kit provides 820 mm depth,
D=300 mm extension kit provides 940 mm depth.

VERTICAL CABLE MANAGEMENT PANEL WITH COVER

Used for hiding and protecting networking cable bundles. Can be easily fixed to 4 post or 2 post racks, left and/or right sides.

It is vertical along the rack and has holes for cable entries and pass.

Please define your colour with your order (RAL 7035 light grey and RAL 9005 black). Unless noted otherwise it is delivered as RAL 9005 black.

SERVER STORAGE AND SHELVING

Designed for server/PC storage and shelving. Managing all devices and servers in professional style, it is functional to access all the way of racks.

It is easy to maintain. All 4 post racks can be bayed side by side.

Can also be used as a device console or device storage rack.

RelayRack Accessories

CASTER AND LEVELLING FEET

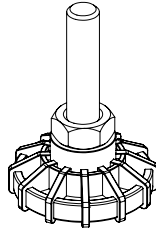

PRODUCT REFERENCE	DESCRIPTION
M22DRTGR	Castor group, 2ea. Front: lockable, rotatable, 2ea. Rear: rotatable Castor Group, 1point fixing, 1set=4ea Load capacity=25kg./castor
M11PNY02	Levelling feet, PVC (1set=4ea), adjustable
M11PNY35	Heavy duty type levelling feet, metal, inner filled with rubber (1set=4ea), height=35mm., adjustable
M11PNY99	Heavy duty type levelling feet, metal, inner filled with rubber (1set=4ea), height=90mm., adjustable

HORIZONTAL CABLE MANAGER

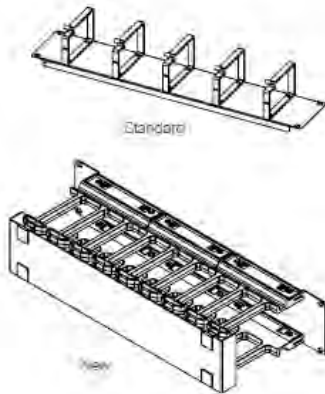

PRODUCT REFERENCE	DESCRIPTION	DIMENSIONS WxHxD (mm)
E440RG1U_01M50	1U 19" cable management panels with 5 metal rings	483x44x80
E440RG1UPLST_01M50	1U 19" cable management panels with 4 plastic rings	483x44x80
E440RG1UN_01M50	1U 19" cable management panel, channel type and with removable cover	483x44x71
E440RG2F_01M50	1U 19" cable management panels with front patch cord access holes, L shaped, rear tray for cable support	483x44x124
E440RG2F_01M50BN	1U 19" cable management panels with front patch cord access holes, basic blank panel shaped	483x44x10
E440RG2U_01M50	2U 19" cable management panels with 5 rings	483x88x76
E440RG1F_01M50	1/2U 19" cable management panels with front patch cord access holes	483x22x100
E440RG2UFT_01M50	2U 19", Cable Management Panels with 5 Metal Rings - Finger Type	483x88x166

VERTICAL CABLE MANAGER

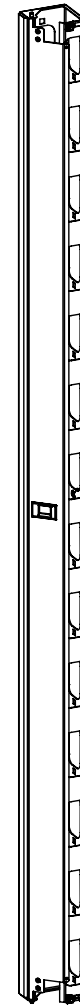

PRODUCT REFERENCE	DESCRIPTION	HxWxD (mm)
M440RG26RLY_01M50	26U Vertical cable management panel 1ea. W=135 mm	135x250x1292
M440RG36RLY_01M50	36U Vertical cable management panel 1ea. W=135 mm	135x250x1736
M440RG42RLY_01M50	42U Vertical cable management panel 1ea. W=135 mm	135x250x2003
M440RG48RLY_01M50	48U Vertical cable management panel 1ea. W=135 mm	135x250x2270
M440RG26RLYG_01M50	26U Vertical cable management panel 1ea. W=260 mm	260x250x1292
M440RG36RLYG_01M50	36U Vertical cable management panel 1ea. W=260 mm	260x250x1736
M440RG42RLYG_01M50	42U Vertical cable management panel 1ea. W=260 mm	260x250x2003
M440RG48RLYG_01M50	48U Vertical cable management panel 1ea. W=260 mm	260x250x2270

Note: Color code "M50" is RAL 9005 black, "M2" RAL 7035 light grey option is available

RelayRack Accessories

BLANK PANELS

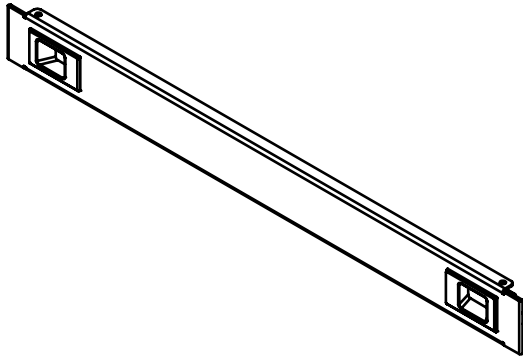

PRODUCT REFERENCE	DESCRIPTION	DIMENSIONS WxHxD (mm)
E44BPN01_0150M	1U 19" Blank panel	483x44x12
E44BPN02_0150M	2U 19" Blank panel	483x88x12
E44BPN03_0150M	3U 19" Blank panel	483x133x12
E44BPN04_0150M	4U 19" Blank panel	483x177x12
E44BPN05_0150M	5U 19" Blank panel	483x222x12
E44BPN06_0150M	6U 19" Blank panel	483x266x12
P44BPN06_01M50	6U 19" Modular plastic blank panel (ABS)	483x266x12

19" KEYBOARD DRAWER

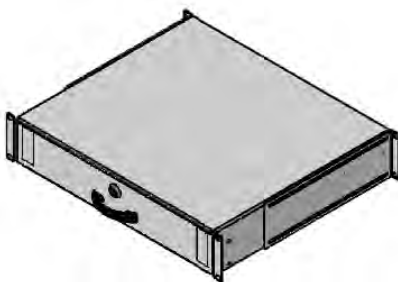

PRODUCT REFERENCE	DESCRIPTION	DIMENSIONS WxHxD (mm)
M44CEK2U_01M50	2U 19" drawer, lockable suitable up to depth=800mm. Cabinets, for D=1000 mm cabinet usage extra brackets available in package, sheet steel material and load carrying capacity is 25 kg.	483x88x400
M44CEK3U_01M50	3U 19" drawer, lockable suitable up to depth=800mm. Cabinets, for D=1000 mm cabinet usage extra brackets available in package, sheet steel material and load carrying capacity is 25 kg.	483x133x400

FIXINGS

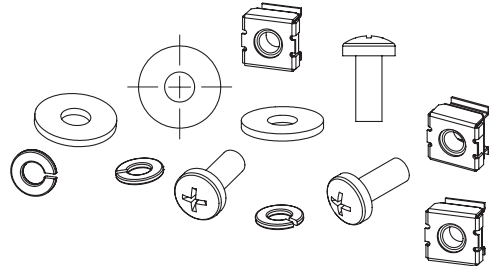

PRODUCT REFERENCE	DESCRIPTION
KFS6X15_20	M6 caged nut, screw, washer (1set=20ea)
KFS6X15_50	M6 caged nut, screw, washer (1set=50ea)

GROUNDING KIT

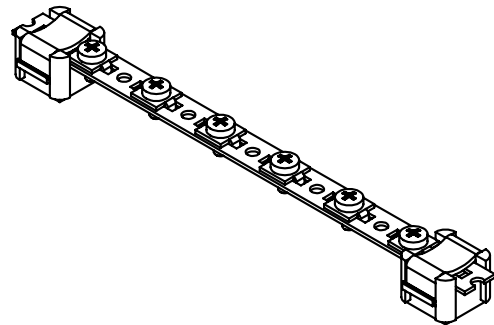

PRODUCT REFERENCE	DESCRIPTION
M44PEB01	Grounding kit, 6 each earthing leads + copper busbar
M44PEB19_01	Grounding kit, 13 each earthing leads + copper busbar

Note: Color code "M50" is RAL 9005 black, "M2" RAL 7035 light grey option is available

TECHNICAL CHARACTERICS

STANDARD COLOUR

Black: RAL 9005, Gray: RAL 7035

FRAMEWORK

TOP AND BOTTOM BASE UNITS

Solid metal 2,5 mm

HORIZONTAL SUPPORT ON BASE AND TOP

Solid metal 2,5 mm

EXTENSION UNITS (D=180 MM D=300 MM)

Solid metal 2,5 mm

UPRIGHTS - FRAME

Solid metal, 1,5 mm

UPRIGHTS CONSTRUCTION

Tightly fixed into top brackets and bottom base units
6 times folded, total 7 bend surfaces

KEY FEATURES

- Main framework is of a structure which increase the mechanical resistance with maximal performance, manufactured Omega style profile system, connected to top bracket units and bottom base units with heavy duty fixing hardware ensuring framework stability. Manufactured and tested to provide axial (x, y, z) resistance that meets EN 61587-1 / 5.2.1 and 5.2.2, external impact resistance that meets EN 61587-1 / 5.3.3.
- With optional top covers, the system can give the appearance of a closet, as well as offering resistance against falling dust on to installed equipment.
- Designed for use a minimally dusty, climatized, and security controlled environment, the system provides a very cost efficient solution.
- The system is shipped in flat pack with a superior transport cost scheme.
- Levelling feet are standard for stability. The cabinet shall meet standards EN 61587-1, IEC 60917, IEC 60297 and RoHS compliant, shall be EAC and TSE certified.

PURCHASED PRODUCT CERTIFICATION

SHEET STEEL

EN 10346: 20015 DX51D+Z, EN 10130: 2006 DC01

ELECTROSTATIC POWDER COATING

ISO6860, ISO2409, ISO1520, ISO2815, ISO6272, ISO7253, ISO6270-1, ISO2812

ISO 9001, RoHS

GLASS

TS EN 12150-1, TS EN 1863-1

LOCK

IEC 62474, REACH, RoHS

CASTORS

ISO 9001, TS EN 12532, RoHS

FAN

IEC 60335-2-80:2002, IEC 60335-1:2010

TESTS AND COMPLIED STANDARDS

TESTS AND COMPLIED STANDARDS

- 1) ISO 9001:2015 Quality Management System
- 2) ISO 14001:2015 Environmental Management System
- 3) ISO 27001:2013 Information Security Management System
- 4) ISO 45001:2018 Occupational Health and Safety Management System
- 5) 19" device mounting uprights IEC 297-1
- 6) EN 61587-1 Mechanical structures for electronic equipment.
- 7) All cabinet sizes complies with IEC 297-2.

RESISTANCE TO ENVIRONMENTAL CONDITIONS AND CORROSION;

STABILITY, MECHANICAL SAFETY, RESISTANCE TO STATIC, DYNAMIC AND MECHANICAL LOADS;

RESISTANCE TO VIBRATION, MECHANICAL SHOCK AND IMPACT;

DEGREES OF MECHANICAL PROTECTION PROVIDED BY THE ENCLOSURE (IP20);

ELECTRICAL GROUNDING CONTINUITY;

FIRE AND FLAME RESISTANCE;

Have been tested according to the standard " EN 61587-1" with the normative standards: IEC 60917, IEC 60297, IEC 60068-1, IEC 60068-2, IEC 60695-11-10, IEC 60950-1, contained and certified by the notified organizations::

TSE CERTIFICATE NO

003788-TSE-08/02

EAC CERTIFICATE NO

0443637, 0776963, 0345864, 0401678, 0776653

CORROSION

ISO 9227 Standard complied by the test report METALTEK AB-0547-T / 0157-1

TRANSPORT

ETS 300 019-1-2 Class 2.3 Comply with internal testing

STORAGE

ETS 300 019-1-1 Class 1.2 Comply with internal testing

SURFACE FINISH

Electrostatic powder coated c/with surface treatment , 80 +/- 5 micron paint thickness

ProLine

Intro

Proline cabinets provide powerful, compact and professional cabling solution for limited U space requirements.

GENERAL CHARACTERISTICS

- 7U, 9U, 12U, 16U, 20U height options
- 80 kg load carrying capacity
- Front door can be opened up to 105°
- Standart colour options are RAL 9005 black and RAL 7035 grey
- U marking device installation uprights
- Additional rear mounting rails
- Extensive range of conventional accessories
- Casters or leveling feet for Stand-alone usage
- Nut and washer connection for earthing
- Lockable & removable smoked safety glass front door
- Lockable & removable side panels
- Removable rear panel





High capacity, Rigid and Well Vented

19" wall-mounted cabinet
for Compact Professional
Networking duty.

GENERAL CHARACTERISTICS

- 450 mm., 560 mm. depth, double sectioned option(+160 mm.) is available for the depth of 450 mm. cabinet
- Rigid body structure due to tightly fixed uprights to the welded chassis sockets and 20-fold frame design
- Vented top cover for passive cooling and active cooling options
- Two 19" adjustable mounting angles in depth. (If needed 2 additional mounting angles could be ordered as accessory)
- Residential (D: 150mm, 300mm) versions: for residential LV infrastructure networking. Various cable entries on top and bottom
- Multiple cable entries; top, bottom and rear
- Cable protecting rubber edge sliding cover mechanism on top and bottom chassis
- Removable plastic cover on rear panel, replaceable with rubber edge sliding cover



ProLine

WALL-MOUNTED CABINETS

DIMENSIONS



PRODUCT REFERENCE	PRODUCT DEFINITION	U SIZE	WIDTH: OVERALL (MM)	DEPTH: OVERALL (MM)	HEIGHT: VERTICAL MOUNTING PROFILE (MM)	HEIGHT: OVERALL (MM)
PRL07U45_01M50	7U 600x450	7	600	450	397	402
PRL09U45_01M50	9U 600x450	9	600	450	485	491
PRL12U45_01M50	12U 600x450	12	600	450	618	624
PRL16U45_01M50	16U 600x450	16	600	450	798	802
PRL20U45_01M50	20U 600x450	20	600	450	976	980
PRL07U56_01M50	7U 600x560	7	600	560	397	402
PRL09U56_01M50	9U 600x560	9	600	560	485	491
PRL12U56_01M50	12U 600x560	12	600	560	618	624
PRL16U56_01M50	16U 600x560	16	600	560	798	802
PRL20U56_01M50	20U 600x560	20	600	560	976	980
PRD07U56_01M50	7U 600x(160+450)	7	600	610	397	402
PRD09U56_01M50	9U 600x(160+450)	9	600	610	495	491
PRD12U56_01M50	12U 600x(160+450)	12	600	610	618	624
PRD16U56_01M50	16U 600x(160+450)	16	600	610	798	802
PRD20U56_01M50	20U 600x(160+450)	20	600	610	976	980

Note: Color code "M50" is RAL 9005 black, "M2" RAL 7035 light grey option is available.



DOUBLE SECTIONED VERSIONS

D: 160+450MM

ProLine series with a depth of 450 mm, it has a mono block wall frame option of D= 160 mm welding which allows double sectioned application. With increased depth, it offers rear access to the devices. Ease access of rear section allows for maintenance and installation from the backside, thanks to the heavy duty hinges and 105 degree opening angle.



STAND ALONE APPLICATION

All ProLine are suitable for stand-alone usage by adding caster group or leveling feet. It provides flexibility to use the cabinet under desks or in narrow places.

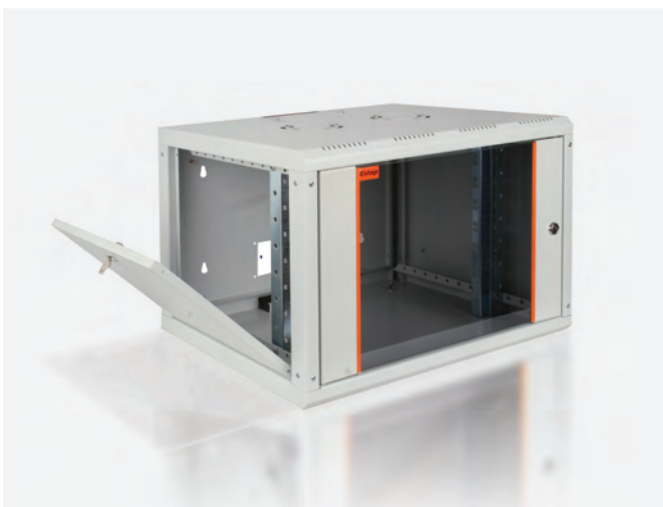

EASY TO MOUNT ON WALL

The back panel of all PROLINE cabinets can be easily removed and a person is sufficient for marking, drilling and wall mounting. The cabinet is then placed, which is mounted (suspended) to the rear panel.

This structure reduces labor cost and provides great convenience for fixing. Without the cabinet mounted on the wall, the user can do all these work from his / her seat and finish. The cabinet is then easily hung on the wall / back panel.

ProLine

WALL-MOUNTED CABINETS

TECHNICAL DRAWINGS (mm)
600X450 MM - 07U/09U/12U/16U/20U

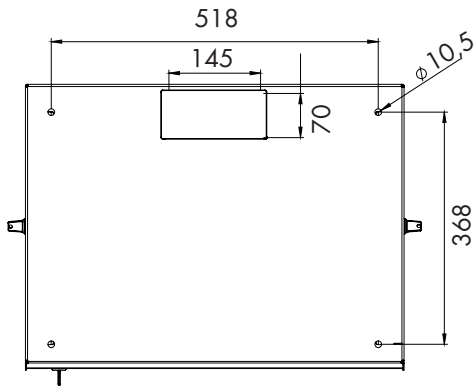

Bottom view

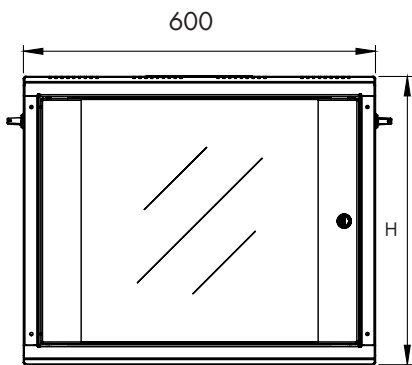

Front view

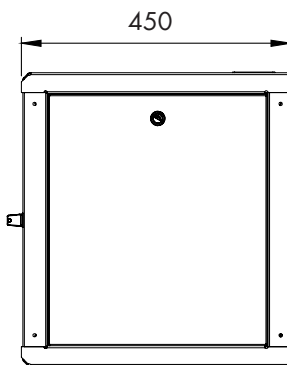

Side view

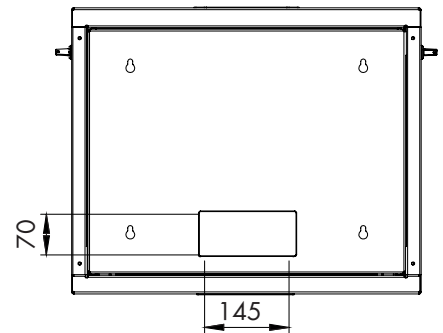

Back view

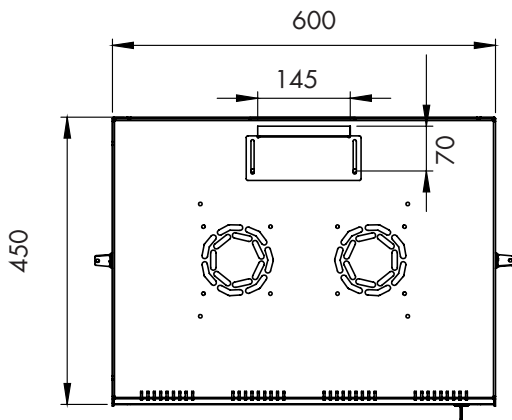

Top view

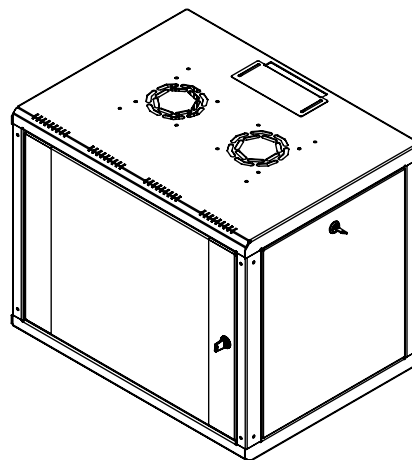

Iso view

H= Enclosure height

TECHNICAL DRAWINGS (mm)
600x560 mm - 7U/9U/12U/16U/20U

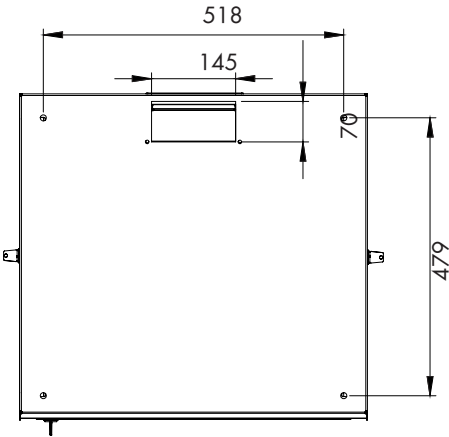

Bottom view

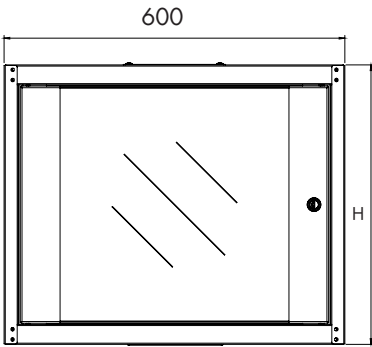

Front view

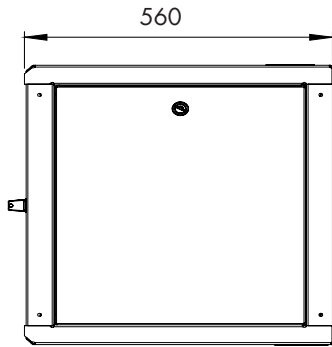

Side view

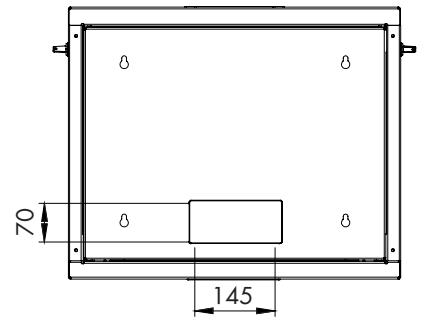

Back view

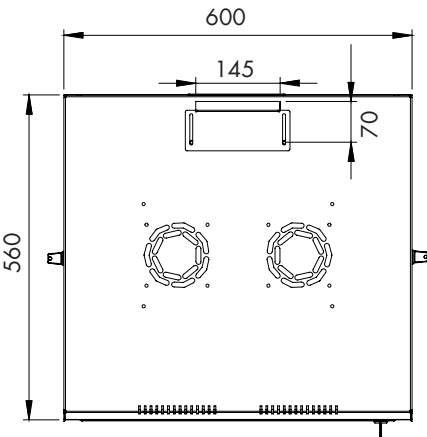

Top view

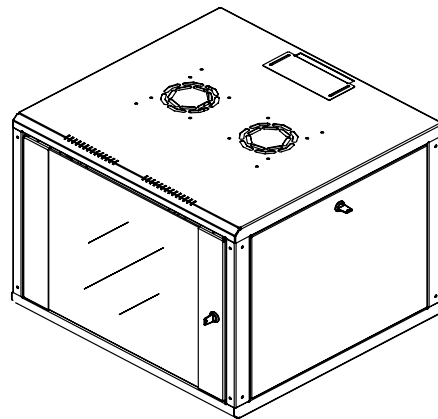

Iso view

H= Enclosure height

H= Enclosure height

ProLine

DOUBLE SECTIONED WALL-MOUNTED CABINETS

TECHNICAL DRAWINGS (mm)

600X450 MM - 600X(160+450) MM

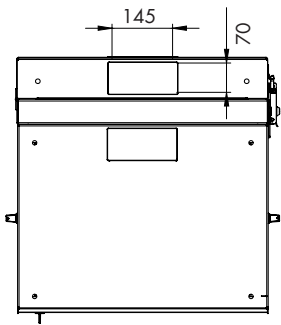

Bottom view

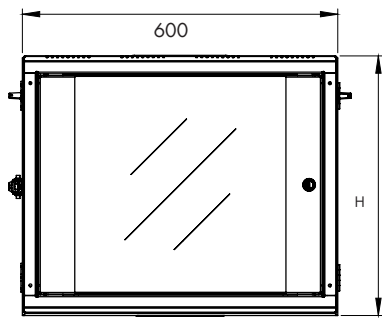

Front view

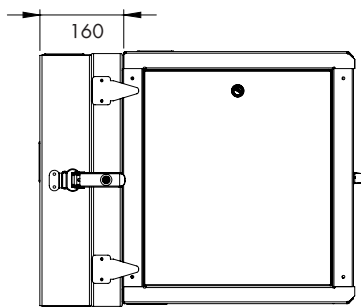

Side view

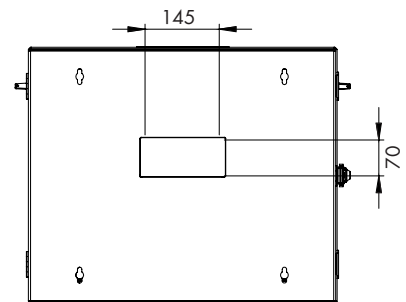

Back view

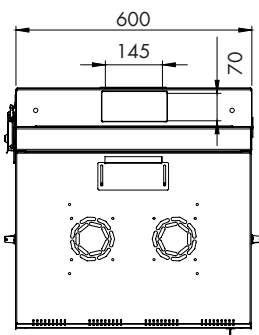

Top view

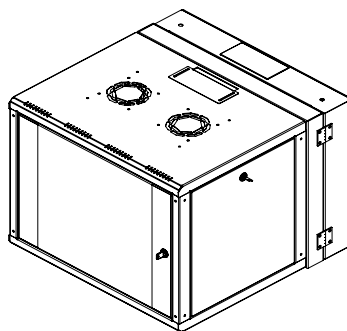

Iso view

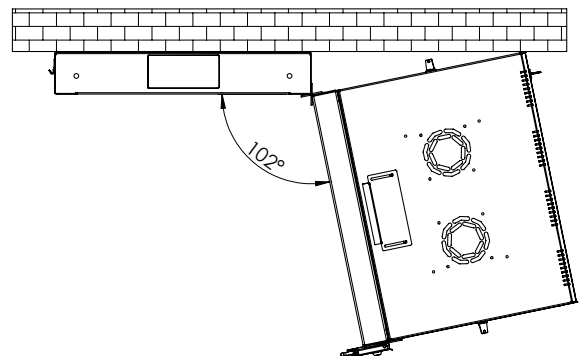

H= Enclosure height

ProLine

RESIDENTIAL WALL-MOUNTED CABINETS

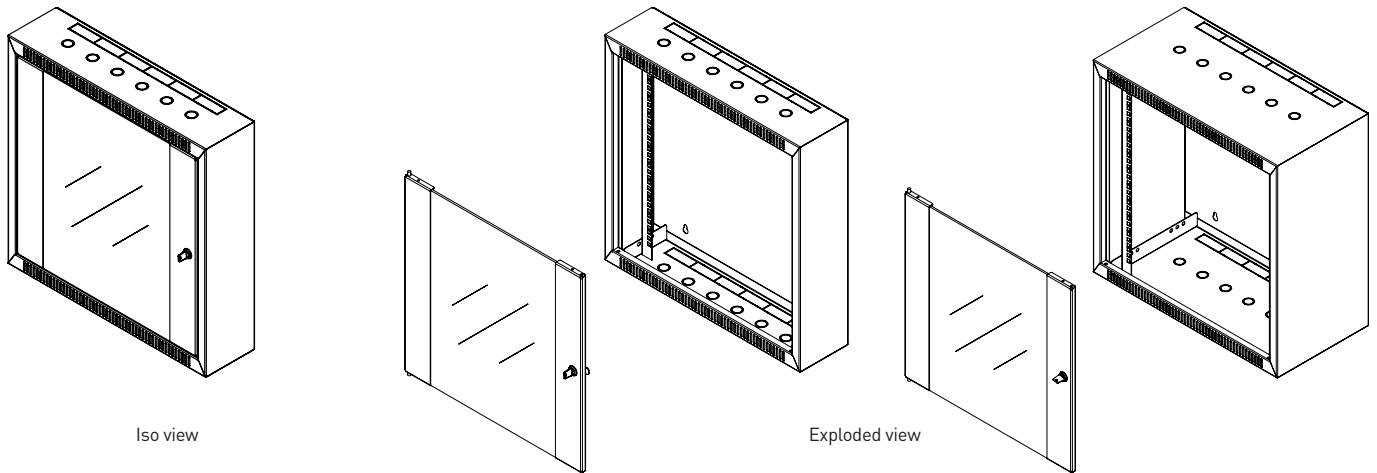

ProLine residential wall mounted cabinets 19" 600 x 150 mm

PRODUCT REFERENCE	PRODUCT DEFINITION	U SIZE	WIDTH:OVERALL (MM)	DEPTH: OVERALL (MM)	HEIGHT: VERTICAL MOUNTING PROFILE (MM)	HEIGHT: OVERALL (MM)
PRL06U615_01M50	6U 600x150	6	600	150	338	344
PRL09U615_01M50	9U 600x150	9	600	150	463	467
PRL12U615_01M50	12U 600x150	12	600	150	596	600

ProLine residential wall mounted cabinets 19" 600 x 300 mm

PRODUCT REFERENCE	PRODUCT DEFINITION	U SIZE	WIDTH:OVERALL (MM)	DEPTH: OVERALL (MM)	HEIGHT: VERTICAL MOUNTING PROFILE (MM)	HEIGHT: OVERALL (MM)
PRL06U630_01M50	6U 600x300	6	600	300	338	344
PRL09U630_01M50	9U 600x300	9	600	300	463	467
PRL12U630_01M50	12U 600x300	12	600	300	596	600

Note: Color code "M50" is RAL 9005 black, "M2" RAL 7035 light grey option is available.

ProLine Accessories

CASTER AND LEVELLING FEET

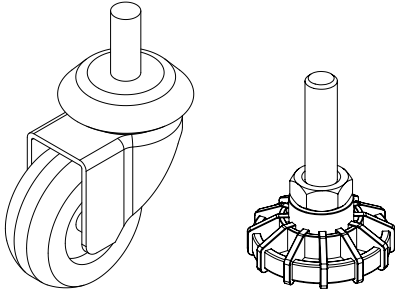

PRODUCT REFERENCE		600x450 mm	600x560 mm	600x450 mm +160 mm
M11PNY02	LEVELLING FEET	x	x	x
G22TKDUV	CASTERS	x	x	x

19" DEVICE UPRIGHTS

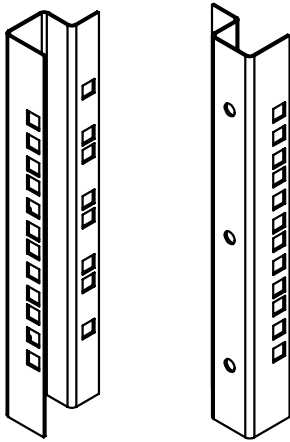

PRODUCT REFERENCE	"U" HEIGHT	600x450 mm	600x560 mm	600x450 mm +160 mm
CMD7UPROLINE	07	x	x	x
CMD9UPROLINE	09	x	x	x
CMD12UPROLINE	12	x	x	x
CMD16UPROLINE	16	x	x	x
CMD20UPROLINE	20	x	x	x

RACK MOUNT SHELF

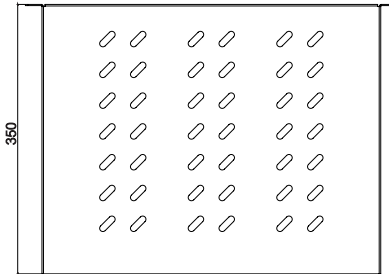
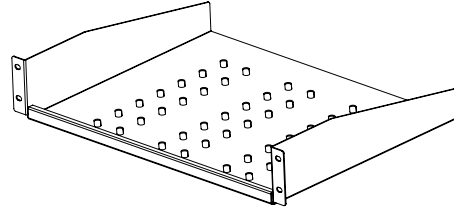

PRODUCT REFERENCE	WxDxH (mm)	600x450 mm	600x560 mm	600x450 mm +160 mm
E44RAK20M50KFS	483x200x44	X	X	X
E44RAK25M50KFS	483x250x44	X	X	X
E44RAK30M50KFS	483x300x44	X	X	X
E44RAK35M50KFS	483x370x88	X	X	X
E44RAK40M50KFS	483x400x44		X	

HORIZONTAL CABLE MANAGER

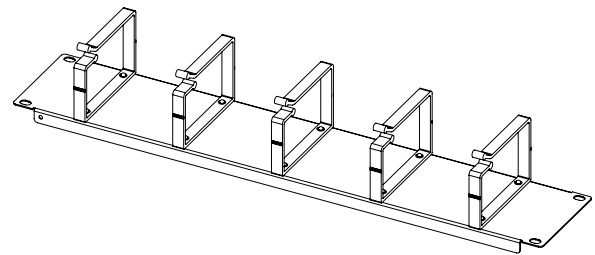

PRODUCT REFERENCE	WxDxH (mm)	600x450 mm	600x560 mm	600x450 mm +160 mm
E44ORG1U_M50	483x80x44	X	X	X
E44ORG2U_M50	483x80x88	X	X	X
E44ORG1UN_M50	483x80x44	X	X	X
E44ORG1F_M50	483x100x22	X	X	X
E44ORG2F_M50	483x124x44	X	X	X
E44ORG2F-BN_M50	483x10x44	X	X	X

Note: Color code "M50" is RAL 9005 black, "M2" RAL 7035 light grey option is available.

ProLine Accessories

FIXED AND SLIDING SHELVES

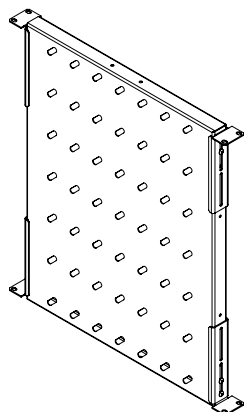

PRODUCT REFERENCE			Distance between uprights	
			Min. (A) (mm)	Max. (B) (mm)
SHLFIX60M50	D= 600 mm fixed shelf module with slots / load capacity 50 kg. / Ral...	Depth of the shelf D= 372 mm, 4-points fixed. only suitable for 600 mm depth cabinets. Load carrying capacity is 50 kg.	355	500

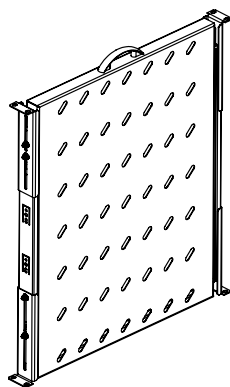

PRODUCT REFERENCE			Distance between uprights	
			Min. (A) (mm)	Max. (B) (mm)
SHLSLD60M50	D= 600 mm sliding shelf module with slots / load capacity 30 kg. / Ral...	Depth of the shelf D= 372 mm, 4-points fixed. only suitable for 600 mm depth cabinets. Load carrying capacity is 30 kg.	337	500

1U 19" KEYBOARD DRAWER

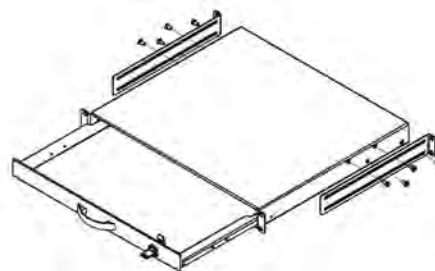

PRODUCT REFERENCE	DESCRIPTION	DIMENSIONS WxHxD (mm)
E44DRW1U_01M50	1U 19" Keyboard drawer (If cabinet is equipped with 4 pcs. 19" rails/ If needed please see 19" profiles angles) sheet steel material and load carrying capacity is 25 kg.	483x44x400

FAN

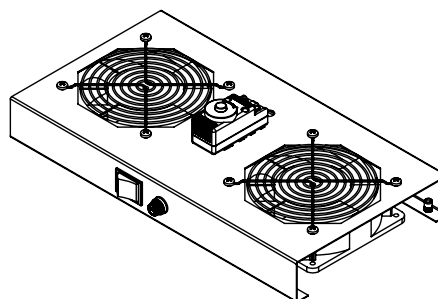

PRODUCT REFERENCE	WxDxH (mm)	600x450 mm	600x560 mm	600x450 mm +160 mm
M11HV1FW_01M50	360x191x44	X	X	X
M11HV2FW_01M50	360x191x44	X	X	X
M11HV1FWT_01M50	360x191x44	X	X	X
M11HV2FWT_01M50	360x191x44	X	X	X
M11HV1FWDT_01M50	360x191x83 (+ 1U 19")	X	X	X
M11HV2FWDT_01M50	360x191x83 (+ 1U 19")	X	X	X

Note: Color code "M50" is RAL 9005 black, "M2" RAL 7035 light grey option is available.

ProLine Accessories

BLANK PANEL

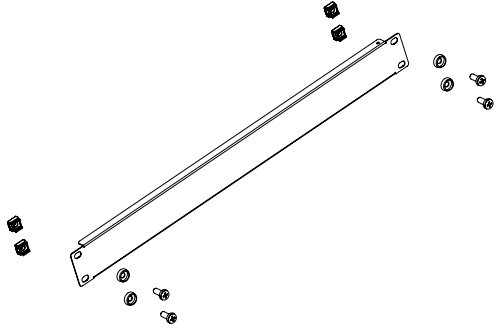

PRODUCT REFERENCE	DESCRIPTION	DIMENSIONS WxHxD (mm)
E44BPN01_0150M	1U 19" Blank panel	483x44x12
E44BPN02_0150M	2U 19" Blank panel	483x88x12
E44BPN03_0150M	3U 19" Blank panel	483x133x12
E44BPN04_0150M	4U 19" Blank panel	483x177x12
E44BPN05_0150M	5U 19" Blank panel	483x222x12
E44BPN06_0150M	6U 19" Blank panel	483x266x12
P44BPN06_01M50	6U 19" Modular plastic blank panel (ABS)	483x266x12

GROUNDING KIT

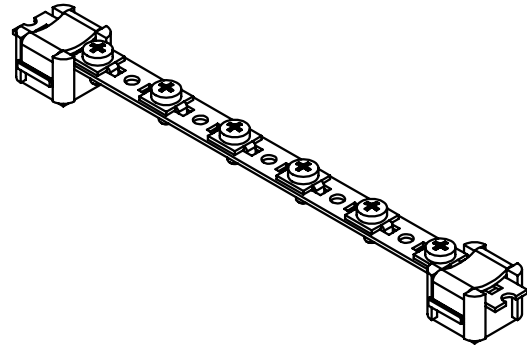

PRODUCT REFERENCE	DESCRIPTION
M44PEB01	Grounding kit, 6 each earthing leads + copper busbar
M44PEB19_01	Grounding kit, 13 each earthing leads + copper busbar

FIXINGS

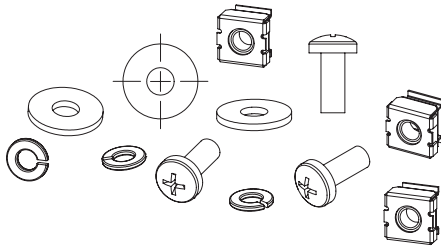

PRODUCT REFERENCE	DESCRIPTION
KFS6X15_20	M6 caged nut, screw, washer (1set=20ea)
KFS6X15_50	M6 caged nut, screw, washer (1set=50ea)

LED LIGHT

PRODUCT REFERENCE	WxDxH (mm)	600x450 mm	600x560 mm	600x450 mm +160 mm
MAYDNLED-IRM	300x30x10	X	X	X

Note: Color code "M50" is RAL 9005 black, "M2" RAL 7035 light grey option is available.

ProLine Wall-Mounted Cabinets

TECHNICAL CHARACTERISTICS

FRONT DOOR

Shatterproof glass with left and right metal frame

GLASS

4 mm thickness full-length smoked, shatterproof, tempered, secure

FRONT DOOR CONSTRUCTION

Single door opening with barrel type lock

FRONT DOOR LOCK

Barrel type, single point locking

ADHESIVE MATERIAL

High density polyurethane DIN 53479, DIN 53505

HINGE SYSTEM

Spring loaded

DOOR OPENING ANGLE AND SWAPPING

105 degree, possible to swap one side to the other

SIDE PANEL

Solid metal, 1,0 mm. Left and right (2 ea.)

CONSTRUCTION

Lockable, removable c/with barrel type lock

LOCK

Barrel type lock unit, single point

REAR PANEL

Solid metal 1,5 mm

Rear panel construction

Mechanically locked with 2 screws from inside

FRAMEWORK

TOP AND BOTTOM BASE UNITS

Solid metal 1,5 mm

CONSTRUCTIONS

Completely welded corner socket system

UPRIGHTS

Solid metal, 1,2 mm

CONSTRUCTION

Tightly fixed into top and bottom base units ,

5 times folded x 4 = 20 folds

INTERIOR PARTS

19" mounting angles

Solid metal, 1,5 mm

There are 2 pcs. 19" mounting angles in front.

Zinc plated, passivated, 8-12 micron

Adjustable in depth

ADDITIONAL TECHNICAL SPECIFICATIONS FOR DOUBLE SECTION WALL MOUNTING CABINETS

DOUBLE SECTION (WALL)

D=160 mm, monoblock, welded, construction

Connected to the front section with zamac hinges system

SWING OPENNING

105 degree

REAR SECTION LOCK

Traverse style , heavy duty

19" MOUNTING ANGLES

Solid metal, 1,5 mm

3 times folded as C profile system

2 ea. in front

Pre-configured as 19"

Zinc plated, passivated, 8-12 micron

Adjustable in depth

TESTS AND COMPLIED STANDARDS

TESTS AND COMPLIED STANDARDS

1) ISO 9001:2015 Quality Management System

2) ISO 14001:2015 Environmental Management System

3) ISO 27001:2013 Information Security Management System

4) ISO 45001:2018 Occupational Health and Safety Management System

5) 19" device mounting uprights IEC 297-1

6) EN 61587-1 Mechanical structures for electronic equipment.

7) All cabinet sizes complies with IEC 297-2.

RESISTANCE TO ENVIRONMENTAL CONDITIONS AND CORROSION; STABILITY, MECHANICAL SAFETY, RESISTANCE TO STATIC, DYNAMIC AND MECHANICAL LOADS;

RESISTANCE TO VIBRATION, MECHANICAL SHOCK AND IMPACT;

DEGREES OF MECHANICAL PROTECTION PROVIDED BY THE ENCLOSURE (IP20);

ELECTRICAL GROUNDING CONTINUITY;

FIRE AND FLAME RESISTANCE;

Have been tested according to the standard " EN 61587-1" with the normative standards: IEC 60917, IEC 60297, IEC 60068-1, IEC 60068-2, IEC 60695-11-10, IEC 60950-1, contained and certified by the notified organizations::

TSE CERTIFICATE NO

003788-TSE-08/02

EAC CERTIFICATE NO

0443637, 0776963, 0345864, 0401678, 0776653

CORROSION

ISO 9227 Standard complied by the test report METALTEK AB-0547-T / 0157-1

TRANSPORT

ETS 300 019-1-2 Class 2.3 Comply with internal testing

STORAGE

ETS 300 019-1-1 Class 1.2 Comply with internal testing

SURFACE FINISH

Electrostatic powder coated c/with surface treatment , 80 +/- 5 micron paint thickness

PURCHASED PRODUCT CERTIFICATION

SHEET STEEL

EN 10346: 20015 DX51D+Z, EN 10130: 2006 DC01

ELECTROSTATIC POWDER COATING

ISO6860, ISO2409, ISO1520, ISO2815, ISO6272, ISO7253, ISO6270-1, ISO2812

ISO 9001, RoHS

GLASS

TS EN 12150-1, TS EN 1863-1

LOCK

IEC 62474, REACH, RoHS

CASTORS

ISO 9001, TS EN 12532, RoHS

FAN

IEC 60335-2-80:2002, IEC 60335-1:2010

ProLine Wall-Mounted Cabinets

KEY FEATURES

ACCESSORIES

FAN SYSTEM; The setting range is between 0-35 °C with digital, analog or ON/OFF switch with 1 or 2 pieces fan controlled thermostat units. It is suitable for installation inside the cabinet with electric cable and internal wiring. Every fan at 50 Hz max. have a noise level of 38 dB and 53 CFM airflow. It has a CE certificate.

CASTER AND/OR LEVELING FEET; The wheels are movable in every direction and the front wheels have a lockable structure. The load carrying capacity of each wheel and each leveling feet is 250 kg.

FIXED AND SLIDING SHELF; Be able to mount from 4 points (2 in front and 2 in rear).

LIGHTING FIXTURE; 19", 1U, with ON/OFF switch, 220 Vac, automatic door with ON/OFF switch or LED with sensor.

GROUNDING CONTINUITY; Grounding continuity in the cabinet complies with IEC 61010-1 standard. For all doors, these grounding cable connections are made with bolts and nuts.

Grounding continuity between the 19" movable mounting profiles and the main body is provided with the toothed nuts and screws.

The Cabinet complies with EN 61587-1, IEC 60917, IEC 60297 standards, and are RoHS compliant, GOST and TSE certified.

Cabinets are manufactured at our factory which has ISO 9001

Quality Management System and ISO 14001: 2004 Environmental

Management System showing our commitment to the environment.





Power,
proficiency,
functionality



ProLine

ProLine wall-mounted cabinets can be used as a floor standing cabinet under table or in any office environment by means of wheel or leveling feet accessories.

EcoLine & EcoLine+

Intro

Ecoline and Ecoline+ cabinets are an ideal solution in the offices and IT rooms for data cabling applications where the limited "U" height requirements and less devices are needed.

GENERAL CHARACTERISTICS

- 4 mm thickness of glass, full-length smoked, shatterproof, tempered, secure
- Full glass door
- 450 mm and 600 mm depth. Double sectioned option (+160 mm) is available for the depth of 450 mm cabinet
- Special structure allowing the adjustment of 19" device uprights throughout the depth
- Multiple cable entries: Top, bottom and rear
- Flatpack delivery option which takes less space in storage and transportation*
- Depending on the different customer needs there are two options available; cabinet with fixed side panels (ECOLINE) and with openable side panels (ECOLINE+)
- Cable protecting rubber edge sliding cover
- All Ecoline&Ecoline+ cabinets can be used stand-alone with casters or leveling feet
- Flexibility to use under desks, narrow places
- Color: RAL 9005 black and RAL 7035 light grey



EcoLine



Strong Capacity and User-Friendly Functionality

New EcoLine wall-mounted cabinet range will make your job much easier with its smart design, advanced features and ease of use.

GENERAL CHARACTERISTICS

EcoLine

- 65 kg. load carrying capacity (for wall-mounted installation)
- Front door can be opened up to 120°
- 4U, 7U, 9U, 12U, 16U, 20U height options
- U marking device installation uprights
- Nut and washer connection for earthing

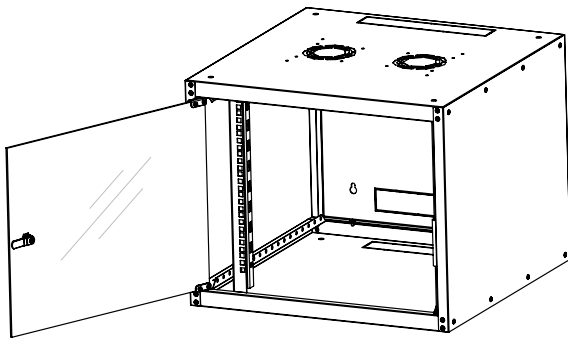

EcoLine+

- 65 kg. load carrying capacity (for wall-mounted installation)
- Front door can be opened up to 125°
- 4U, 7U, 9U, 12U, 16U, 20U height options
- U marking device installation uprights
- Easy openable side panels
- Nut and washer connection for earthing

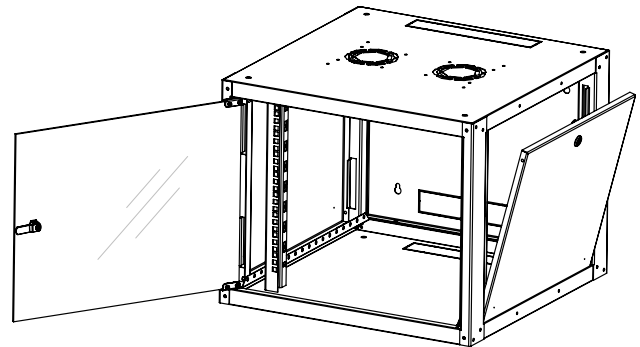

EcoLine+

EcoLine & EcoLine+

TECHNICAL CHARACTERISTICS



EcoLine

- Assembled
- 450 mm and 600 mm depth, double sectioned option (+160 mm) is available for the depth of 450 mm cabinet
- Standard front door: Single opening full glass, 4 mm thickness full-length smoked, shatterproof, tempered, secure
- Protection level: IP20
- Load carrying capacity: 65 kg.
- 19" uprights: solid metal, 1,5 mm of thickness, 3 bending
- Side panels: Complete metal, 1 mm
- Rear panel: 1,5 mm of thickness
- Lock: Barrel type locking cabinet, single point locking
- Surface finish: Durable electrostatic powder coating against impact, scratches and dust
- Corrosion: ISO9227 and ASTM B 117-85
- Standards: European Union and international standards; ISO, IEC, EN, Gost, ROHS, UL etc.
- Color: RAL 9005 black and RAL 7035 light grey

EcoLine+

- Assembled / Flatpack
- 450 mm and 600 mm depth, double sectioned option (+160 mm) is available for the depth of 450 mm cabinet
- Standard front door: Single opening full glass, 4 mm thickness full-length smoked, shatterproof, tempered, secure
- Protection level: IP20
- Load carrying capacity: 65 kg.
- 19" uprights: solid metal, 1,5 mm of thickness, 3 bending
- Side panels: Complete metal, 0,8 mm
- Rear panel: 1,5 mm of thickness
- Side panels openable
- Lock: Barrel type locking cabinet, single point locking (front door and side covers)
- Surface finish: Durable electrostatic powder coating against impact, scratches and dust
- Corrosion: ISO9227 and ASTM B 117-85
- Standards: European Union and international standards; ISO, IEC, EN, Gost, ROHS, UL etc.
- Color: RAL 9005 black and RAL 7035 light grey



The EcoLine range is available in flatpack packaging, taking up to **50%** less space

Shelves

2-points fixed shelf



4-points fixed and sliding shelves



4-points shelves are only suitable for 600 mm depth cabinets.

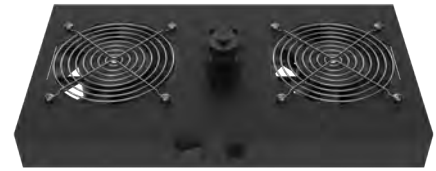

Advanced ventilation system

EcoLine and EcoLine plus are equipped with many features for more effective ventilation. Your devices are now more efficient and safe with the circulation system providing optimum air circulation inside the cabinet.

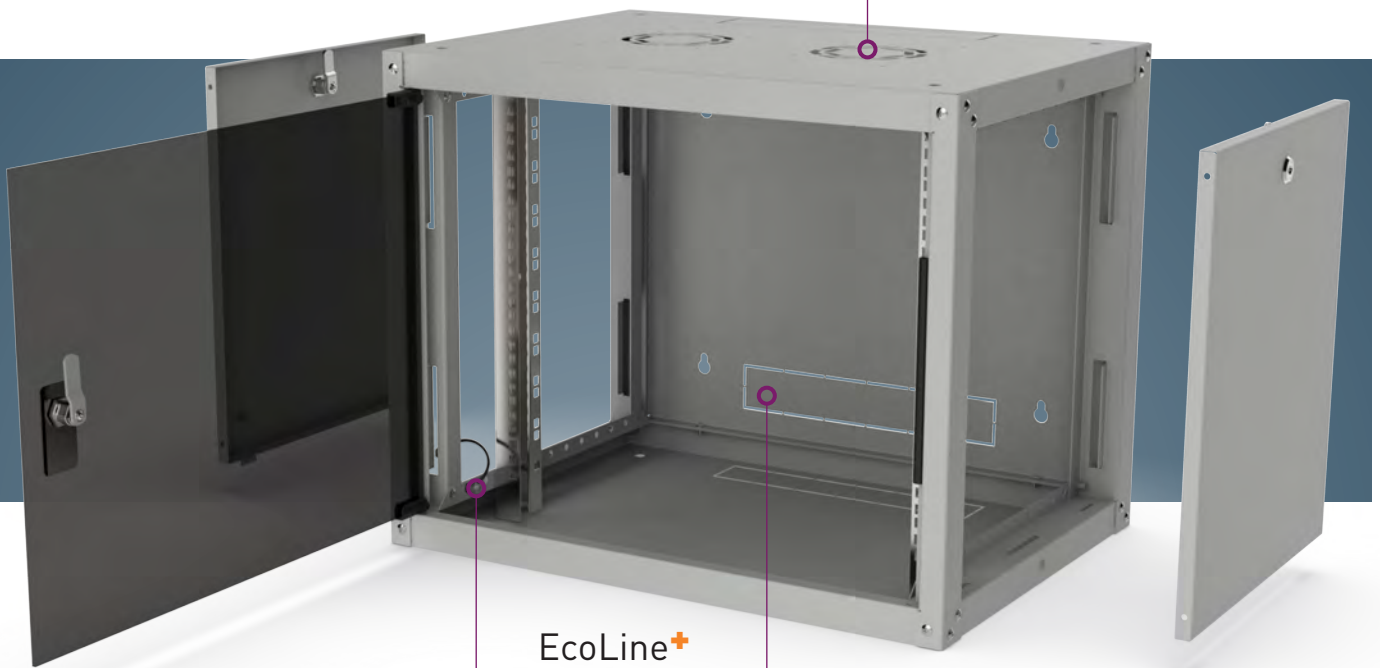

EcoLine+

Earthing is so easy with the connection of nut and washer!



The perfect solution for a large amount of cables: pre-cut cable entries in 3 different point.

- Top, bottom and rear cable entries with the dimension of 300 mm x 50 mm
- Optional brushed cable entry to prevent dust, which will keep the optimum air circulation inside the cabinet

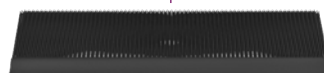

EcoLine & EcoLine+

PRODUCT REFERENCE

PRODUCT REFERENCE	MOUNTED/ FLATPACK	"U" HEIGHT	WIDTH	DEPTH	HEIGHT	HEIGHT WITH CASTERS	HEIGHT WITH LEVELLING FEET	"A" SIZE	
EC04U6045_M..FGF	ECOLINE MOUNTED	04	600	450	270	333	295	63	
EC07U6045_M..FGF		07	600	450	405	468	430	197	
EC09U6045_M..FGF		09	600	450	495	558	520	286	
EC12U6045_M..FGF		12	600	450	626	689	651	419	
EC16U6045_M..FGF		16	600	450	805	868	830	597	
EC20U6045_M..FGF		20	600	450	982	1045	1007	775	
EC04U6060_M..FGF		04	600	600	270	333	295	63	
EC07U6060_M..FGF		07	600	600	405	468	430	197	
EC09U6060_M..FGF		09	600	600	495	558	520	286	
EC12U6060_M..FGF		12	600	600	626	689	651	419	
EC16U6060_M..FGF		16	600	600	805	868	830	597	
EC20U6060_M..FGF		20	600	600	982	1045	1007	775	
ECP04U6045_M..FGF	ECOLINE PLUS MOUNTED	04	600	450	270	333	295	63	
ECP07U6045_M..FGF		07	600	450	405	468	430	197	
ECP09U6045_M..FGF		09	600	450	495	558	520	286	
ECP12U6045_M..FGF		12	600	450	626	689	651	419	
ECP16U6045_M..FGF		16	600	450	805	868	830	597	
ECP20U6045_M..FGF		20	600	450	982	1045	1007	775	
ECP04U6060_M..FGF		04	600	600	270	333	295	63	
ECP07U6060_M..FGF		07	600	600	405	468	430	197	
ECP09U6060_M..FGF		09	600	600	495	558	520	286	
ECP12U6060_M..FGF		12	600	600	626	689	651	419	
ECP16U6060_M..FGF		16	600	600	805	868	830	597	
ECP20U6045_M..FGF		20	600	600	982	1045	1007	775	

PRODUCT REFERENCE

PRODUCT REFERENCE	MOUNTED/ FLATPACK	"U" HEIGHT	WIDTH	DEPTH	HEIGHT	HEIGHT WITH CASTERS	HEIGHT WITH LEVELLING FEET	"A" SIZE
ECP04U6045_M..FGF_F	ECOLINE PLUS FLATPACK	04	600	450	270	333	295	63
ECP07U6045_M..FGF_F		07	600	450	405	468	430	197
ECP09U6045_M..FGF_F		09	600	450	495	558	520	286
ECP12U6045_M..FGF_F		12	600	450	626	689	651	419
ECP16U6045_M..FGF_F		16	600	450	805	868	830	597
ECP20U6045_M..FGF_F		20	600	450	982	1045	1007	775
ECP04U6060_M..FGF_F		04	600	600	270	333	295	63
ECP07U6060_M..FGF_F		07	600	600	405	468	430	197
ECP09U6060_M..FGF_F		09	600	600	495	558	520	286
ECP12U6060_M..FGF_F		12	600	600	626	689	651	419
ECP16U6060_M..FGF_F		16	600	600	805	868	830	597
ECP20U6060_M..FGF_F		20	600	600	982	1045	1007	775

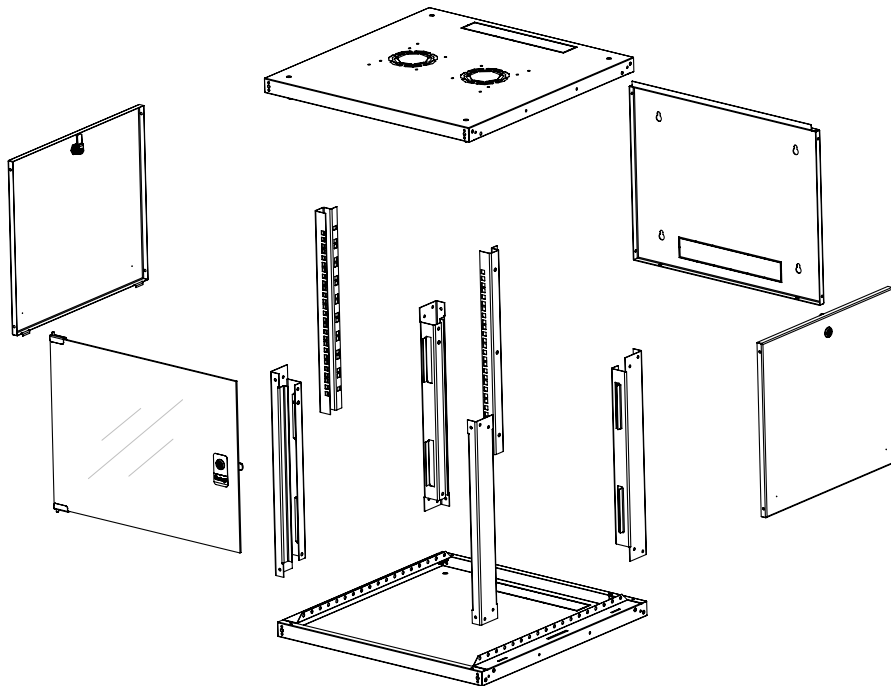

Exploded view

Abbreviations:

EC: Ecoline
 ECP: Ecoline Plus
 Color code: M2 for grey, M50 for black.
 FGF: Full glass front door
 F: Flatpack

Example reference selection:

Description: Ecoline Plus 9U with 600 mm x 600 mm dimensions, black, flatpack
 Reference: ECP09U6060_M50_FGF_F

EcoLine & EcoLine+

TECHNICAL DRAWINGS ECOLINE (mm)

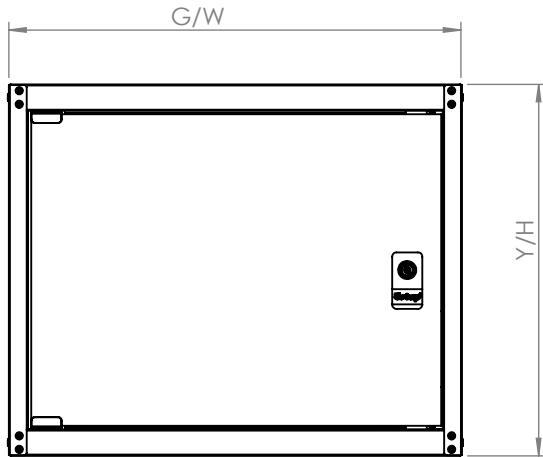

Front view

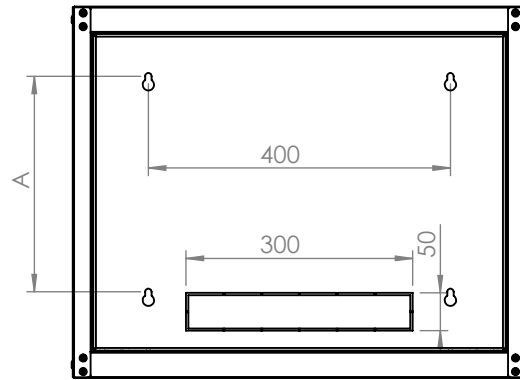

Rear view

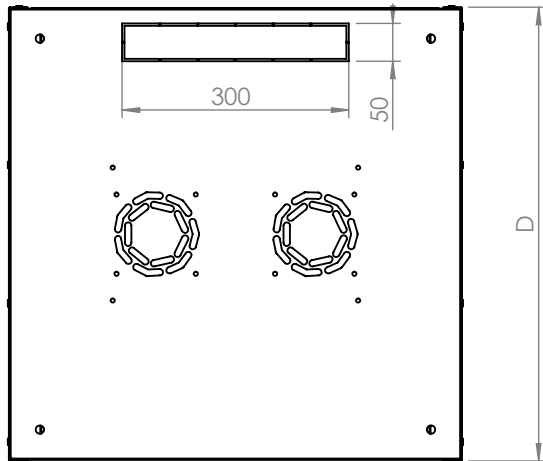

Top view

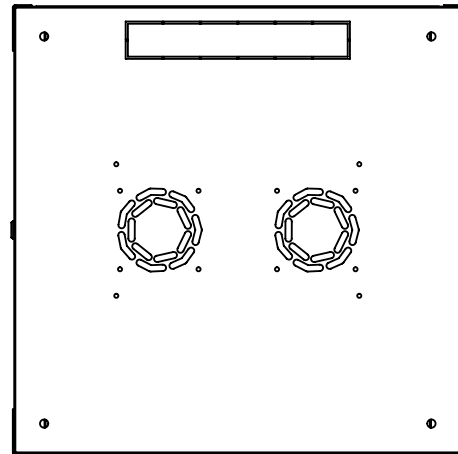

Door opening top view

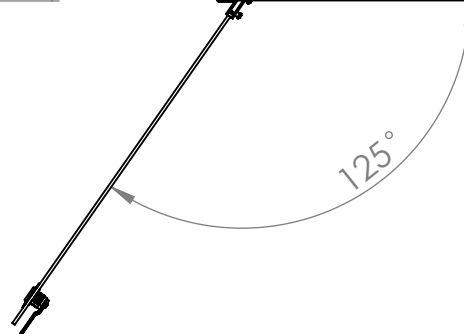

TECHNICAL DRAWINGS ECOLINE+ (mm)

D (mm)	E (mm)
450	330
600	482

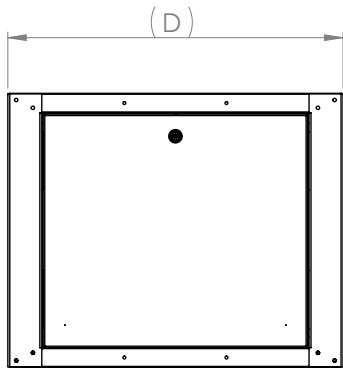

Side view

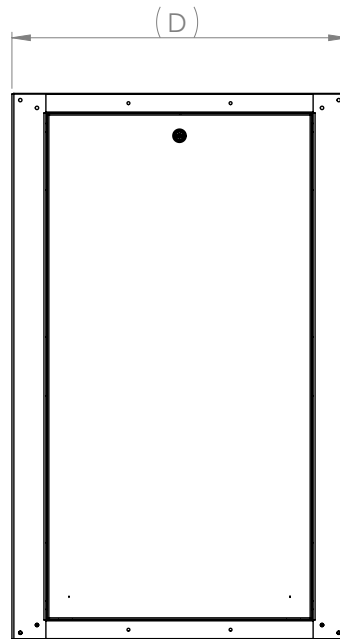

Side view

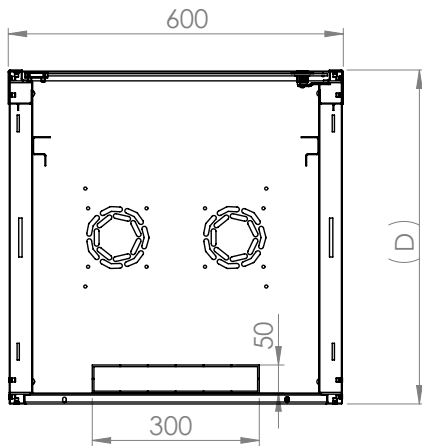

Top view

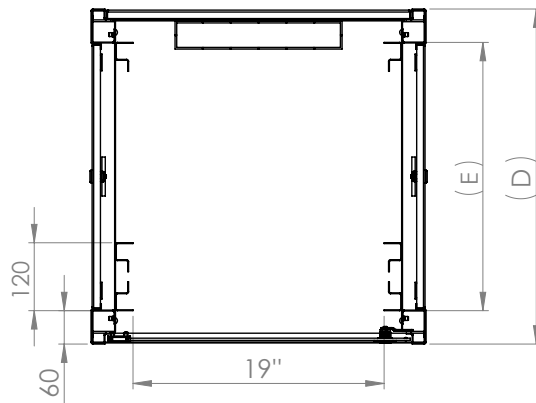

Back view

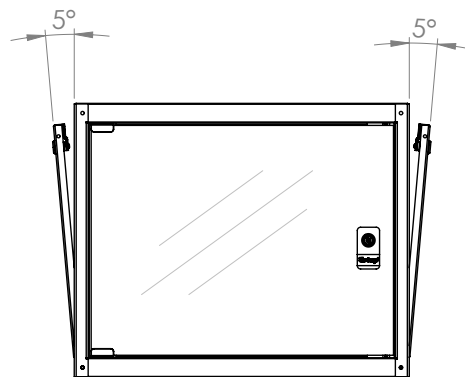

Opening of 5 degree is enough to remove the side panels

TECHNICAL DRAWINGS (mm)

For the Ecoline and Ecoline+ series with a depth of 450 mm, it has a monoblock wall frame option of D= 160 mm welding which allows double sectioned application. With increased depth, it offers rear access to the devices.

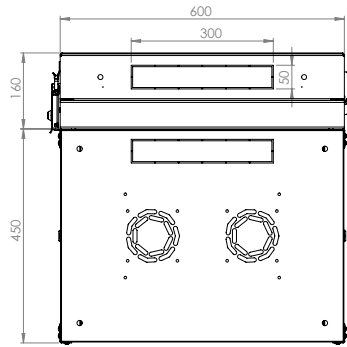
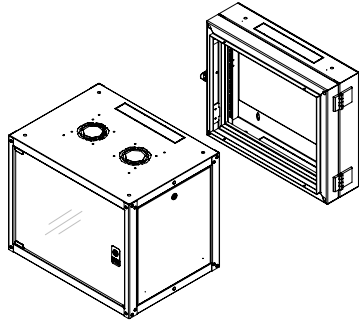

ECOLINE+

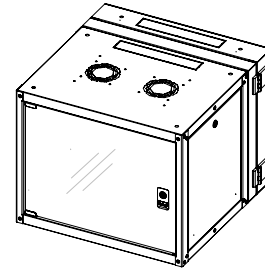
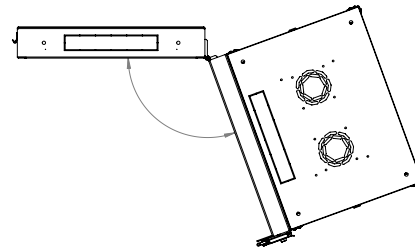

PRODUCT REFERENCE	WxD (mm)
ECDS4U6016_M50	600 x 160
ECDS7U6016_M50	600 x 160
ECDS9U6016_M50	600 x 160
ECDS12U6016_M50	600 x 160
ECDS16U6016_M50	600 x 160
ECDS20U6016_M50	600 x 160

Color code: M2 for grey and M50 for black

ECOLINE

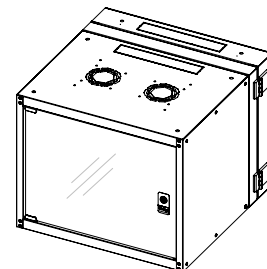
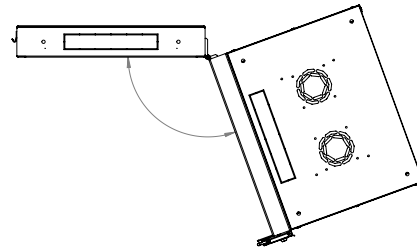
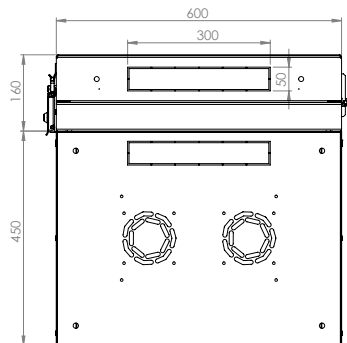
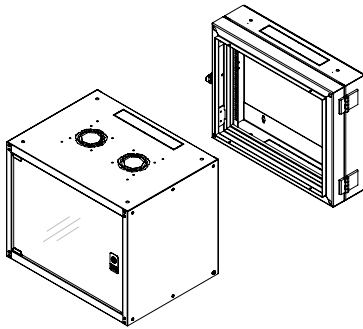

EcoLine&Ecoline+ Accessories

CASTER AND LEVELLING FEET

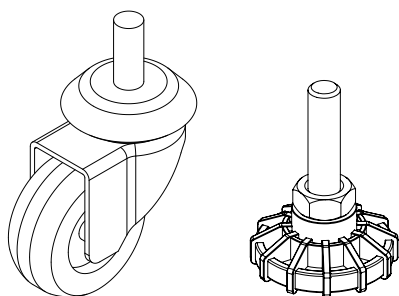

PRODUCT REFERENCE		600x450 mm	600x600 mm	600x450 mm +160 mm
M11PNY02	LEVELLING FEET	x	x	x
G22TKDUV	CASTERS	x	x	x

19" DEVICE UPRIGHTS

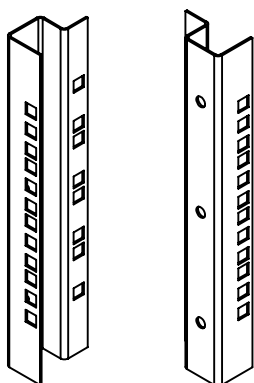

PRODUCT REFERENCE	"U" HEIGHT	600x450 mm	600x600 mm	600x450 mm +160 mm
CMD4UPROLINE	04	x	x	x
CMD7UPROLINE	07	x	x	x
CMD9UPROLINE	09	x	x	x
CMD12UPROLINE	12	x	x	x
CMD16UPROLINE	16	x	x	x
CMD20UPROLINE	20	x	x	x

RACK MOUNT SHELF

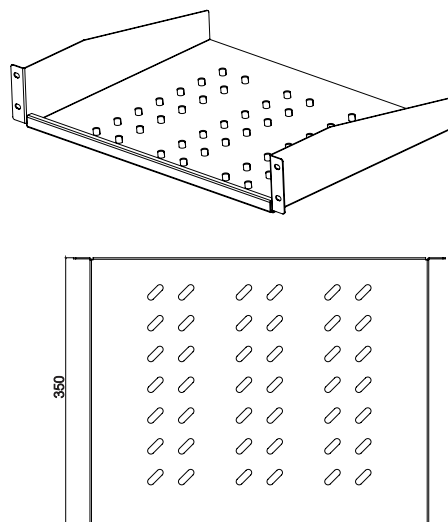

PRODUCT REFERENCE	WxDxH (mm)	600x450 mm	600x600 mm	600x450 mm +160 mm
E44RAK20M50KFS	483x200x44	X	X	X
E44RAK25M50KFS	483x250x44	X	X	X
E44RAK30M50KFS	483x300x44	X	X	X
E44RAK35M50KFS	483x370x88	X	X	X
E44RAK40M50KFS	483x400x44		X	

HORIZONTAL CABLE MANAGER

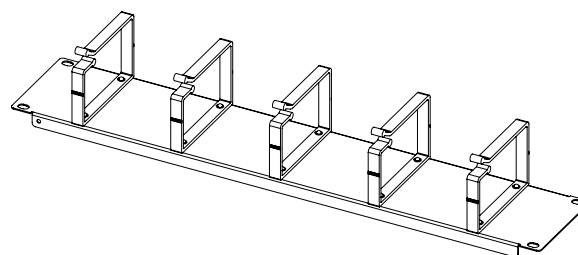

PRODUCT REFERENCE	WxDxH (mm)	600x450 mm	600x600 mm	600x450 mm +160 mm
E44ORG1U_01M50	483x80x44	X	X	X
E44ORG2U_01M50	483x80x88	X	X	X
E44ORG1UN_01M50	483x80x44	X	X	X
E44ORG1F_01M50	483x100x22	X	X	X
E44ORG2F_01M50	483x124x44	X	X	X
E44ORG2F-BN_01M50	483x10x44	X	X	X

Note: Color code "M50" is RAL 9005 black, "M2" RAL 7035 light grey option is available.

EcoLine&Ecoline+ Accessories

FIXED AND SLIDING SHELVES

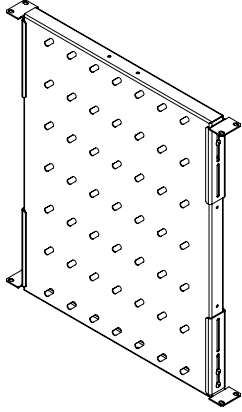

PRODUCT REFERENCE			Distance between uprights	
			Min. (A) (mm)	Max. (B) (mm)
SHLFIX60M50	D= 600 mm fixed shelf module with slots / load capacity 50 kg. / Ral...	Depth of the shelf D= 372 mm, 4-points fixed. only suitable for 600 mm depth cabinets. Load carrying capacity is 50 kg.	355	500

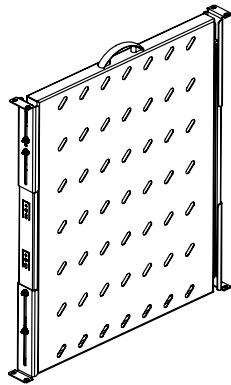

PRODUCT REFERENCE			Distance between uprights	
			Min. (A) (mm)	Max. (B) (mm)
SHLSLD60M50	D= 600 mm sliding shelf module with slots / load capacity 30 kg. / Ral...	Depth of the shelf D= 372 mm, 4-points fixed. only suitable for 600 mm depth cabinets. Load carrying capacity is 30 kg.	337	500

1U 19" KEYBOARD DRAWER

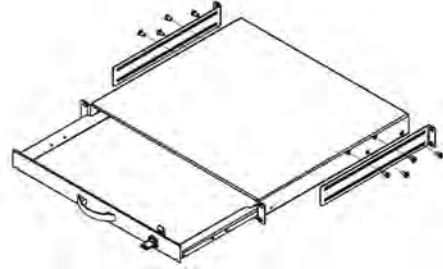

PRODUCT REFERENCE	DESCRIPTION	DIMENSIONS WxHxD (mm)
E44DRW1U_01M50	1U 19" Keyboard drawer (If cabinet is equipped with 4 pcs. 19" rails/ If needed please see 19" profiles angles) sheet steel material and load carrying capacity is 25 kg.	483x44x400

FAN

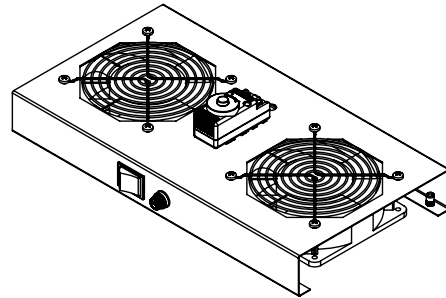

PRODUCT REFERENCE	WxDxH (mm)	600x450 mm	600x600 mm	600x450 mm +160 mm
M11HV1FW_01M50	360x191x44	X	X	X
M11HV2FW_01M50	360x191x44	X	X	X
M11HV1FWT_01M50	360x191x44	X	X	X
M11HV2FWT_01M50	360x191x83	X	X	X
M11HV1FWDT_01M50	360x191x83 (+ 1U 19")	X	X	X
M11HV2FWDT_01M50	360x191x83 (+ 1U 19")	X	X	X

LED LIGHT

PRODUCT REFERENCE	WxDxH (mm)	600x450 mm	600x600 mm	600x450 mm +160 mm
MAYDNLED-IRM	300x30x10	X	X	X

Note: Color code "M50" is RAL 9005 black, "M2" RAL 7035 light grey option is available.

EcoLine&Ecoline+ Accessories

FIXINGS

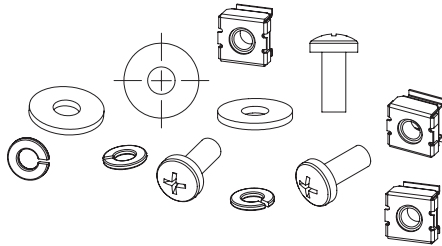

PRODUCT REFERENCE	DESCRIPTION
KFS6X15_20	M6 caged nut, screw, washer (1set=20ea)
KFS6X15_50	M6 caged nut, screw, washer (1set=50ea)

GROUNDING KIT

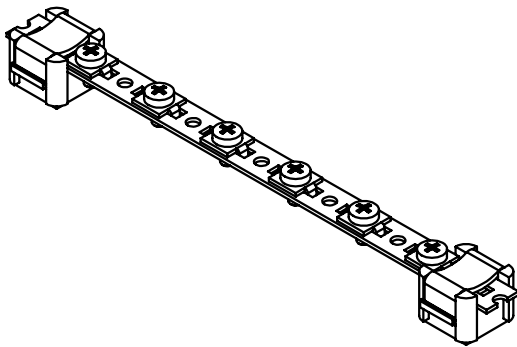

PRODUCT REFERENCE	DESCRIPTION
M44PEB01	Grounding kit, 6 each earthing leads + copper busbar
M44PEB19_01	Grounding kit, 13 each earthing leads + copper busbar

BLANK PANELS

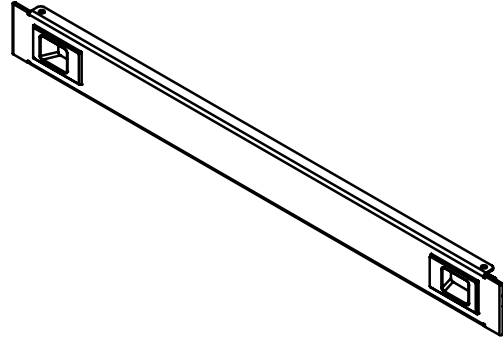

PRODUCT REFERENCE	DESCRIPTION	DIMENSIONS WxHxD (mm)
E44BPN01_0150M	1U 19" Blank panel	483x44x12
E44BPN02_0150M	2U 19" Blank panel	483x88x12
E44BPN03_0150M	3U 19" Blank panel	483x133x12
E44BPN04_0150M	4U 19" Blank panel	483x177x12
E44BPN05_0150M	5U 19" Blank panel	483x222x12
E44BPN06_0150M	6U 19" Blank panel	483x266x12
P44BPN06_01M50	6U 19" Modular plastic blank panel (ABS)	483x266x12

Note: Color code "M50" is RAL 9005 black, "M2" RAL 7035 light grey option is available.

EcoLine & EcoLine+

TECHNICAL CHARACTERISTICS

LOAD CARRYING CAPACITY; load carrying capacity is 65 kg.

TOP AND BOTTOM CHASSIS; Top and bottom chassis which has a twisted monoblock design has a structure that will increase the resistance and strength of the cabinet. The perforated top panel consists of special vent holes for ventilation and the fan module system allows for installation of a maximum of 2 fans. In the Ecoline version, each side panel is fixed with M5 rivets to the top and bottom chassis.

The 450 mm depth Ecoline and Ecoline plus series have a D = 160 mm, welded, wallmounted monoblock frame option which allows double sectioned cabinet application. Thus, provides the possibility of increasing depth and offers access to the rear of the devices also.

FRONT AND REAR COVERS; According to EN 12150-1: 2000 standard, the front door has an antistatic, secure and smoked glass (4mm thickness), decorative lane structure. The front door can be opened up to 125°, can be locked and unlocked with "O" type lock unit.

The structure of the rear panel can be mechanically locked from the inside with a standard 2 screws, allowing the back panel to be used like a wall bracket.

SIDE PANELS; There are 2 options available; cabinet with fixed side panels and cabinet with openable side panels. In the fixed version of the side panels, the panels have a fixed rivet.

CABLE ENTRIES; Brushed cable entries which are pre-cut on the top, bottom and rear side of the cabinet with the dimension of 300 mm x 50 mm.

DIMENSIONS; Complies with IEC 60297 standard. Cabinets are (4U/7U/9U/12U/16U/20U) height, 600 mm. width and 450 mm or 600 mm. depth.

DELIVERY OPTION; Both assembled and flatpack options are available in the version with side panels openable (ECOLINE PLUS).

19" UPRIGHTS; The 19" (in.) "U" marked device mounting bracket (2 in front) is a part of the cabinet interior configuration.

KEY FEATURES

ACCESSORIES

FAN SYSTEM; The setting range is between 0-35 °C with digital, analog or ON/OFF switch with 1 or 2 pieces fan controlled thermostat units. It is suitable for installation inside the cabinet with electric cable and internal wiring. Every fan at 50 Hz max. have a noise level of 38 dB and 53 CFM airflow. It has a CE certificate.

CASTER AND/OR LEVELING FEET; The wheels are movable in every direction and the front wheels have a lockable structure. The load carrying capacity of each wheel and each leveling feet is 250 kg.

FIXED AND SLIDING SHELF; Be able to mount from 4 points (2 in front and 2 in rear).

LIGHTING FIXTURE; 19", 1U, with ON/OFF switch, 220 Vac, automatic door with ON/OFF switch or LED with sensor.

GROUNDING CONTINUITY; Grounding continuity in the cabinet complies with IEC 61010-1 standard. For all doors, these grounding cable connections are made with bolts and nuts.

Grounding continuity between the 19" movable mounting profiles and the main body is provided with the toothed nuts and screws.

The Cabinet complies with EN 61587-1, IEC 60917, IEC 60297 standards, and are RoHS compliant, GOST and TSE certified.

Cabinets are manufactured at our factory which has ISO 9001 Quality Management System and ISO 14001: 2004 Environmental Management System showing our commitment to the environment.

TESTS AND COMPLIED STANDARDS

TESTS AND COMPLIED STANDARDS

- 1) ISO 9001:2015 Quality Management System
- 2) ISO 14001:2015 Environmental Management System
- 3) ISO 27001:2013 Information Security Management System
- 4) ISO 45001:2018 Occupational Health and Safety Management System
- 5) 19" device mounting uprights IEC 297-1
- 6) EN 61587-1 Mechanical structures for electronic equipment.
- 7) All cabinet sizes complies with IEC 297-2.

RESISTANCE TO ENVIRONMENTAL CONDITIONS AND CORROSION; STABILITY, MECHANICAL SAFETY, RESISTANCE TO STATIC, DYNAMIC AND MECHANICAL LOADS;

RESISTANCE TO VIBRATION, MECHANICAL SHOCK AND IMPACT; DEGREES OF MECHANICAL PROTECTION PROVIDED BY THE ENCLOSURE (IP20);

ELECTRICAL GROUNDING CONTINUITY;

FIRE AND FLAME RESISTANCE;

Have been tested according to the standard " EN 61587-1" with the normative standards: IEC 60917, IEC 60297, IEC 60068-1, IEC 60068-2, IEC 60695-11-10, IEC 60950-1, contained and certified by the notified organizations::

TSE CERTIFICATE NO

003788-TSE-08/02

EAC CERTIFICATE NO

0443637, 0776963, 0345864, 0401678, 0776653

CORROSION

ISO 9227 Standard complied by the test report METALTEK AB-0547-T / 0157-1

TRANSPORT

ETS 300 019-1-2 Class 2.3 Comply with internal testing

STORAGE

ETS 300 019-1-1 Class 1.2 Comply with internal testing

SURFACE FINISH

Electrostatic powder coated c/with surface treatment , 80 +/- 5 micron paint thickness

PURCHASED PRODUCT CERTIFICATION

SHEET STEEL

EN 10346: 20015 DX51D+Z, EN 10130: 2006 DC01

ELECTROSTATIC POWDER COATING

ISO6860, ISO2409, ISO1520, ISO2815, ISO6272, ISO7253, ISO6270-1, ISO2812

ISO 9001, RoHS

GLASS

TS EN 12150-1, TS EN 1863-1

LOCK

IEC 62474, REACH, RoHS

CASTORS

ISO 9001, TS EN 12532, RoHS

FAN

IEC 60335-2-80:2002, IEC 60335-1:2010



EcoLine & EcoLine+

Depending on the different customer needs there are two options available; cabinet with fixed side panels (ECOLINE) and with openable side panels (ECOLINE+)



SohoLine

Intro

SohoLine cabinets provide an economical solution for wall-mounted networking application. This series is a range of wall-mounted enclosures for use in offices, factories or any places where a reduced amount of space is required.



GENERAL CHARACTERISTICS

- 6U, 7U, 9U, 12U height options
- Depth is 400 mm. for 7U, 9U, 12U and 300 mm. for 6U
- Width is 520 mm. for 19" and 292 mm. for 10".
- 30 kg. load carrying capacity (for wall mounted installation)
- Protection level: IP20
- Extensive range of accessories
- Color: RAL 9005 black and RAL 7035 light grey
- U marking device installation uprights
- Nut and washer connection for earthing
- Front door can be opened up to 220°
- Special structure allowing the adjustment of 19" device uprights throughout the depth
- Cost-effective flatpack design



Modular, Practical and Compact Design

SohoLine 19" and 10" wall-mounted cabinets offer sleek and user friendly design for fast installations at compact locations.

GENERAL CHARACTERISTICS

- 4 mm thickness of glass, full-length smoked, shatterproof, tempered, secure
- Rear panel can be mechanically locked with 4 screws from the inside
- Front door is lockable and removable.
- Rubber edge sliding mechanism for top or bottom
- Plastic and sliding covers swappable between top and bottom
- Rigid frame construction in steel sheet, rapidly dismantled with 3 screws per corner
- Top panel is available for fan module system
- Saves up to 70% of Shipment and 50% of labor cost (due to a 5 minute assembly time)
- Quick assembly using 3 screws per edge



SohoLine

SOHOLINE 19" WALL-MOUNTED CABINETS DIMENSIONS

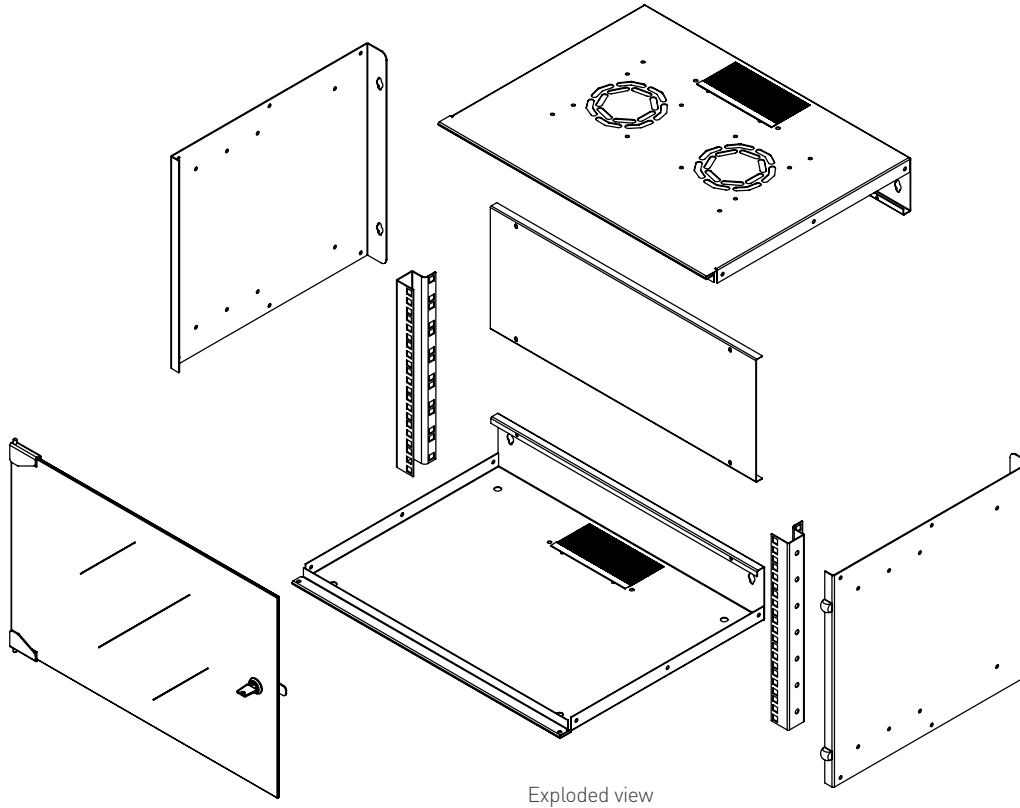

PRODUCT REFERENCE	PRODUCT DEFINITION	U SIZE	WIDTH: OVERALL (MM)	DEPTH: OVERALL (MM)	HEIGHT: VERTICAL MOUNTING PROFILE (MM)	HEIGHT: OVERALL (MM)
SOH06U30_01M50	06U 520x300	6	520	300	267	319
SOH07U40_01M50	7U 520x400	7	520	400	312	359
SOH09U40_01M50	9U 520x400	9	520	400	401	448
SOH12U40_01M50	12U 520x400	12	520	400	535	520

REFERENCE CODE CREATION

Example: SOH06U30_01M50



Note: Color code "M50" is RAL 9005 black, "M2" RAL 7035 light grey option is available.

SOHOLINE 19" WALL-MOUNTED CABINETS TECHNICAL DRAWINGS

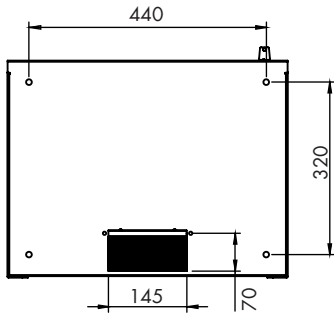

Bottom view

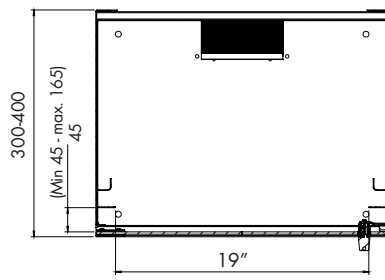

Mounting profile

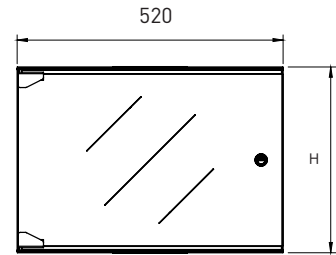

Front view

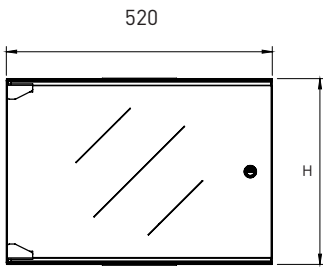

Front view

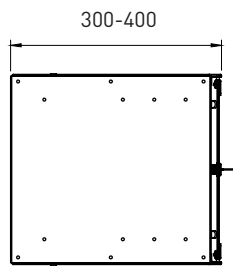

Side view

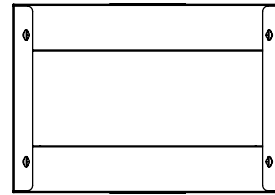

Back view

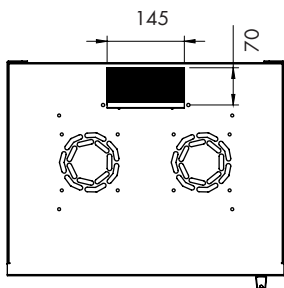

Top view

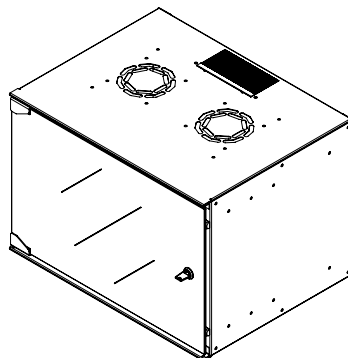

Iso view

H= Enclosure height

SohoLine

SOHOLINE 10" WALL-MOUNTED CABINETS DIMENSIONS

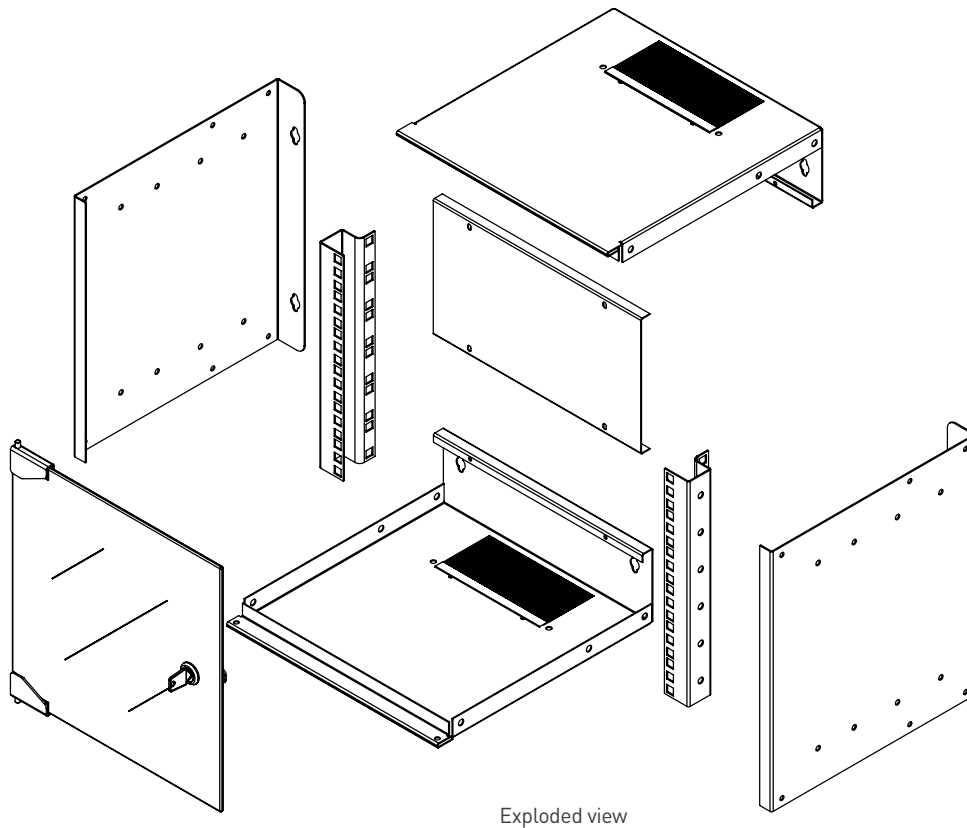

PRODUCT REFERENCE	PRODUCT DEFINITION	U SIZE	WIDTH: OVERALL (MM)	DEPTH: OVERALL (MM)	HEIGHT: VERTICAL MOUNTING PROFILE (MM)	HEIGHT: VERTICAL MOUNTING PROFILE (MM)	HEIGHT: OVERALL (MM)
SOH06U25_01M50	10" 6U wall mounting cabinet	6	292	300	267	319	334

Note: Color code "M50" is RAL 9005 black, "M2" RAL 7035 light grey option is available.

SOHOLINE 10" WALL MOUNTED CABINETS TECHNICAL DRAWINGS

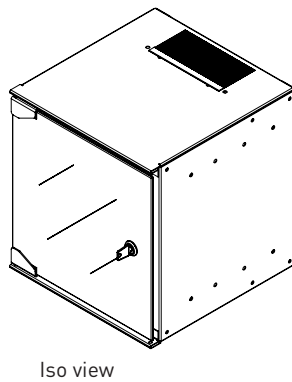
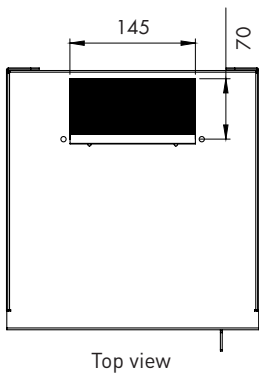
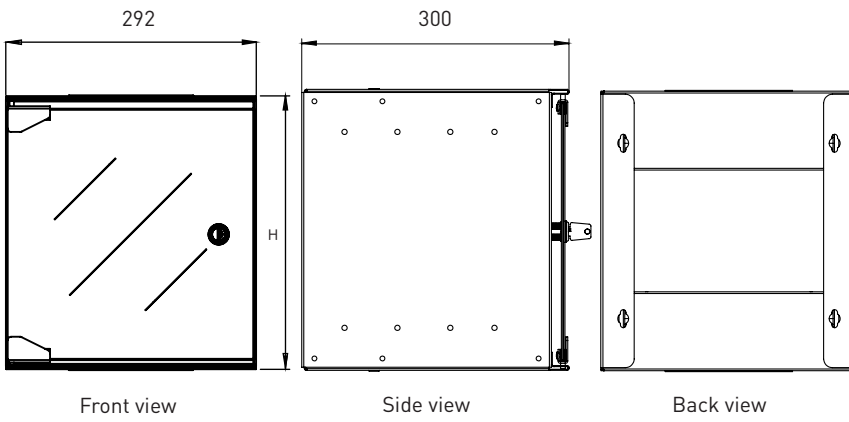
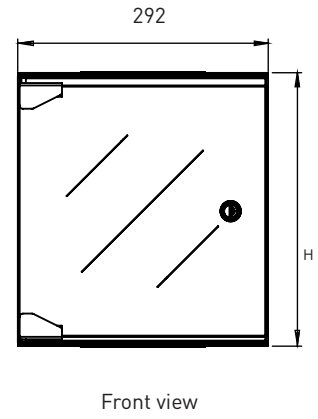
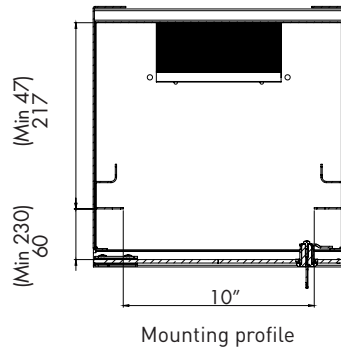
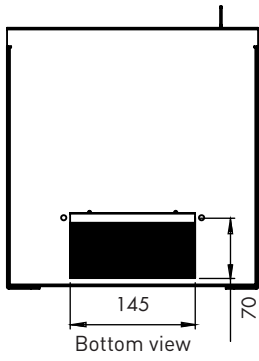

H= Enclosure height

SohoLine Accessories

CASTER AND LEVELLING FEET

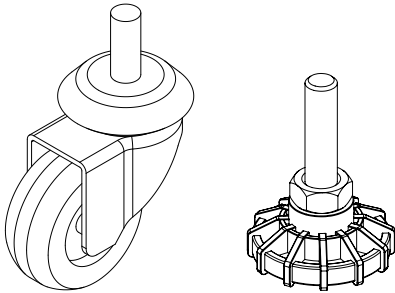

PRODUCT REFERENCE	DESCRIPTION	520x300 (19") mm	520x400 (19") mm	292x300 (10") mm
M11PNY02	LEVELLING FEET	x	x	
G22TKDUV	CASTERS	x	x	x

RACK MOUNT SHELF

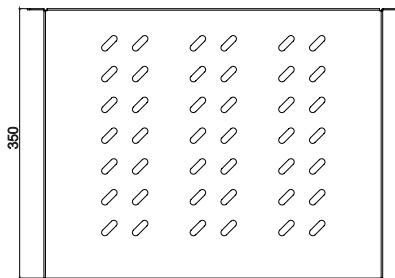
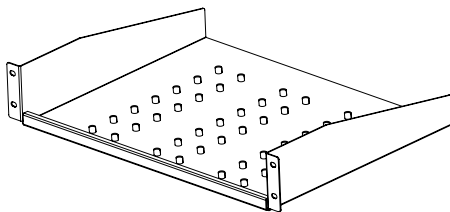

PRODUCT REFERENCE	WxDxH (mm)	520x300 (19") mm	520x400 (19") mm	292x300 (10") mm
E44RAK20M50KFS	483x200x44	X	X	
E44RAK25M50KFS	483x250x44	X	X	
E44RAK30M50KFS	483x300x44		X	
SOHSR10M50KFS	254x152x44			x

HORIZONTAL CABLE MANAGER

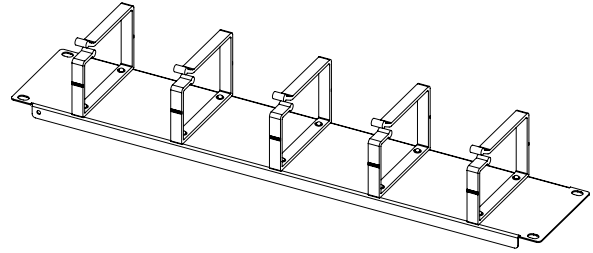

PRODUCT REFERENCE	WxDxH (mm)	520x300 (19") mm	520x400 (19") mm	292x300 (10") mm
E44ORG1U_01M50	483x80x44	X	X	
E44ORG2U_01M50	483x80x88	X	X	
E44ORG1UN_01M50	483x80x44	X	X	
E44ORG1F_01M50	483x100x22	X	X	
E44ORG2F_01M50	483x124x44	X	X	
E44ORG2F-BN_01M50	483x10x44	X	X	
SOHORG10KNC_01M50	254x80x44			X

FAN

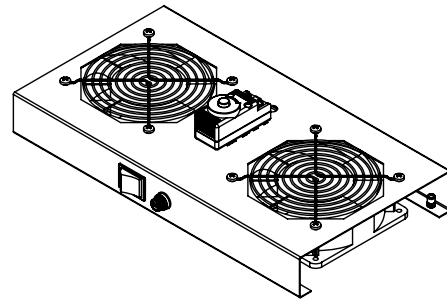

PRODUCT REFERENCE	WxDxH (mm)	520x300 (19") mm	520x400 (19") mm	292x300 (10") mm
M11HV1FW_01M50	360x191x44	X	X	X
M11HV2FW_01M50	360x191x44	X	X	X
M11HV1FWD_01M50	360x191x44	X	X	X
M11HV2FWD_01M50	360x191x83	X	X	X
M11HV1FWD_01M50	360x191x83 (+ 1U 19")	X	X	X
M11HV2FWD_01M50	360x191x83 (+ 1U 19")	X	X	X

Note: Color code "M50" is RAL 9005 black, "M2" RAL 7035 light grey option is available.

SohoLine Accessories

BLANK PANEL

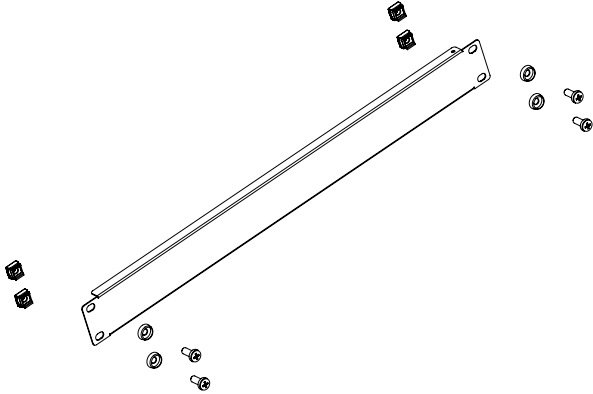

PRODUCT REFERENCE	DESCRIPTION	DIMENSIONS WxHxD (mm)
E44BPN01_0150M	1U 19" Blank panel	483x44x12
E44BPN02_0150M	2U 19" Blank panel	483x88x12
E44BPN03_0150M	3U 19" Blank panel	483x133x12
E44BPN04_0150M	4U 19" Blank panel	483x177x12
E44BPN05_0150M	5U 19" Blank panel	483x222x12
E44BPN06_0150M	6U 19" Blank panel	483x266x12
P44BPN06_01M50	6U 19" Modular plastic blank panel (ABS)	483x266x12

FIXINGS

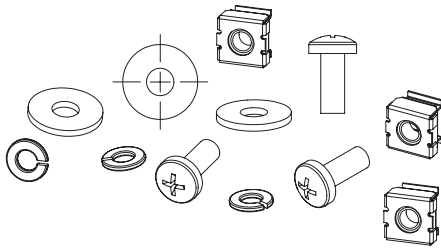

PRODUCT REFERENCE	DESCRIPTION
KFS6X15_20	M6 caged nut, screw, washer (1set=20ea)
KFS6X15_50	M6 caged nut, screw, washer (1set=50ea)

LED LIGHT

PRODUCT REFERENCE	WxDxH (mm)	520x300 (19") mm	520x400 (19") mm	292x300 (10") mm
MAYDNLED-IRM	300x30x10	X	X	

GROUNDING KIT

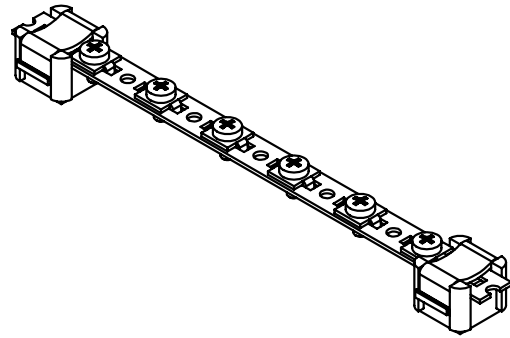

PRODUCT REFERENCE	DESCRIPTION
M44PEB01	Grounding kit, 6 each earthing leads + copper busbar
M44PEB19_01	Grounding kit, 13 each earthing leads + copper busbar

SohoLine

TECHNICAL CHARACTERISTICS

Main framework must be with a structure which increases mechanical resistance and offer aesthetic appearance, manufactured with "U" shaped side panels closing on the top and bottom case for framework

stability. Manufactured and tested to provide axial (x, y, z) resistance that meets EN 61587-1 / 5.2.1 and 5.2.2, and external impact resistance that meets EN 61587-1 / 5.3.3.

Bottom and upper case have a structure which increases resistance and strength of cabinet; monoblock bended top and bottom housing cases provide increased stability. Each side panel body is screwed to top and bottom cases with M5x10 screws. Cable access at top case is via a brushed access plate that blocks dust inlet. A plastic cable entry cover plate housed at bottom case can be replaced with the brushed cable entry on top; of cables to enter from bottom.

Rear panel in standard mechanically locked with 4 screws from inside.

Side panels are non-opening screwed style, for maximum stability.

Front door is glass which is tempered, anti-static, secure and smoked glass (4 mm thickness), according to EN 12150-1:2000 standard. It can open 220 degrees, is removable and lockable Vented top panel housing with a dedicated space for ventilation, fan module system allows easy installation of max. 2 fans.

19"(inch) mounting angles for 2 ea. in front are part of the cabinets interior configuration. The cabinet meets EN 61587-1, IEC 60917, IEC 60297 standards, RoHS compliancy, EAC and TSE certified.

Cabinets are manufactured in our factory which has ISO 9001: 2008 Quality Assurance System and our responsibility for environment with ISO 14001:2004 Environmental Management System.

KEY FEATURES

ACCESSORIES

FAN SYSTEM; The setting range is between 0-35 °C with digital, analog or ON/OFF switch with 1 or 2 pieces fan controlled thermostat units. It is suitable for installation inside the cabinet with electric cable and internal wiring. Every fan at 50 Hz max. have a noise level of 38 dB and 53 CFM airflow. It has a CE certificate.

CASTER AND/OR LEVELING FEET; The wheels are movable in every direction and the front wheels have a lockable structure. The load carrying capacity of each wheel and each leveling feet is 250 kg.

FIXED AND SLIDING SHELF; Be able to mount from 4 points (2 in front and 2 in rear).

LIGHTING FIXTURE; 19", 1U, with ON/OFF switch, 220 Vac, automatic door with ON/OFF switch or LED with sensor.

GROUNDING CONTINUITY; Grounding continuity in the cabinet complies with IEC 61010-1 standard. For all doors, these grounding cable connections are made with bolts and nuts.

Grounding continuity between the 19" movable mounting profiles and the main body is provided with the toothed nuts and screws.

The Cabinet complies with EN 61587-1, IEC 60917, IEC 60297 standards, and are RoHS compliant, GOST and TSE certified.

Cabinets are manufactured at our factory which has ISO 9001 Quality Management System and ISO 14001: 2004 Environmental Management System showing our commitment to the environment.

TESTS AND COMPLIED STANDARDS

TESTS AND COMPLIED STANDARDS

- 1) ISO 9001:2015 Quality Management System
- 2) ISO 14001:2015 Environmental Management System
- 3) ISO 27001:2013 Information Security Management System
- 4) ISO 45001:2018 Occupational Health and Safety Management System
- 5) 19" device mounting uprights IEC 297-1
- 6) EN 61587-1 Mechanical structures for electronic equipment.
- 7) All cabinet sizes complies with IEC 297-2.

**RESISTANCE TO ENVIRONMENTAL CONDITIONS AND CORROSION;
STABILITY, MECHANICAL SAFETY, RESISTANCE TO STATIC, DYNAMIC
AND MECHANICAL LOADS;**

**RESISTANCE TO VIBRATION, MECHANICAL SHOCK AND IMPACT;
DEGREES OF MECHANICAL PROTECTION PROVIDED BY THE
ENCLOSURE (IP20);**

ELECTRICAL GROUNDING CONTINUITY;

FIRE AND FLAME RESISTANCE;

Have been tested according to the standard " EN 61587-1" with the normative standards: IEC 60917, IEC 60297, IEC 60068-1, IEC 60068-2, IEC 60695-11-10, IEC 60950-1, contained and certified by the notified organizations::

TSE CERTIFICATE NO

003788-TSE-08/02

EAC CERTIFICATE NO

0443637, 0776963, 0345864, 0401678, 0776653

CORROSION

ISO 9227 Standard complied by the test report METALTEK AB-0547-T / 0157-1

TRANSPORT

ETS 300 019-1-2 Class 2.3 Comply with internal testing

STORAGE

ETS 300 019-1-1 Class 1.2 Comply with internal testing

SURFACE FINISH

Electrostatic powder coated c/with surface treatment , 80 +/- 5 micron paint thickness

PURCHASED PRODUCT CERTIFICATION

SHEET STEEL

EN 10346: 20015 DX51D+Z, EN 10130: 2006 DC01

ELECTROSTATIC POWDER COATING

ISO6860, ISO2409, ISO1520, ISO2815, ISO6272, ISO7253, ISO6270-1, ISO2812

ISO 9001, RoHS

GLASS

TS EN 12150-1, TS EN 1863-1

LOCK

IEC 62474, REACH, RoHS

CASTORS

ISO 9001, TS EN 12532, RoHS

FAN

IEC 60335-2-80:2002, IEC 60335-1:2010



Small office and
home office applications



SoHoLine

SoHoLine cabinets make your job easier with their robust, convenient structure and practical usage features in office environments.

Soho SlimLine

Intro

Soho Slimline cabinets provides an aesthetic, functional, decorative and economic solution for cabling installations.

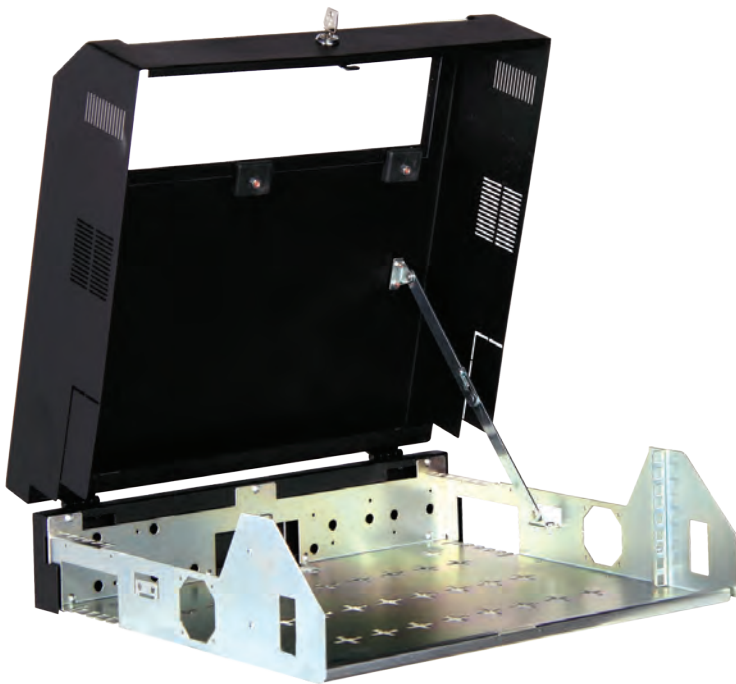

GENERAL CHARACTERISTICS

- Width is 500 mm
- Depth is 470 mm
- Height is 140 mm (Vertical)
- Easy to access
- Completely opening front door
- Plexi-glass front window in front door
- Lockable front door
- Mechanical distance holder
- Large cable openings for multi-cable entry
- Breakable fan holes
- Fast installation, low manpower
- Time saving installation
- Heavy duty base plate
- 19" 5U device mounting capacity (2 vertical + 3 horizontal)
- 80 kg. load carrying capacity (for wall mounted installation)



Sturdy and Sleek Design

Soho Slimline rack cabinets provide a professional use thanks to the thin and functional structure.

GENERAL CHARACTERISTICS

- Heavy duty hinges
- Slim depth only 140 mm
- The front cover open with a mechanical stop and locked with "O" type lock unit
- Sturdy and strong steel construction
- Thanks to its functional structure for up to 24 users, network distribution is made easy
- Punched holes for device fixing or cable management
- The bottom chassis have a monobloc twisted and welded structure
- Surface finish: Durable electrostatic powder coating against impact, scratches and dust
- Color: RAL 9005 black and RAL 7035 light grey
- High Quality Package: Shrink plastic wrapped with on high density cardboard. Styrofoam supported corners



Soho SlimLine

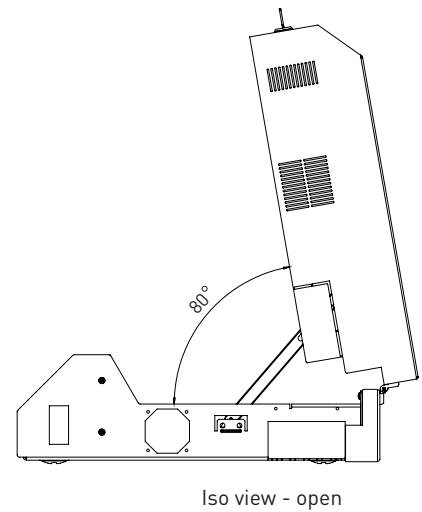
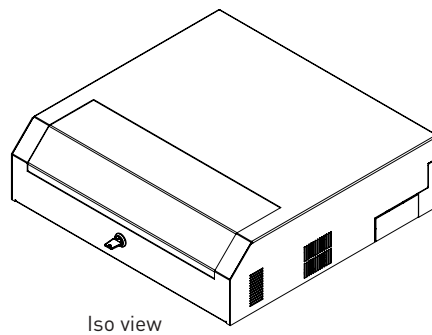
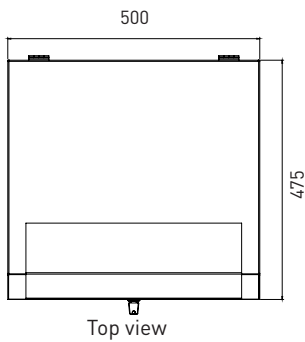
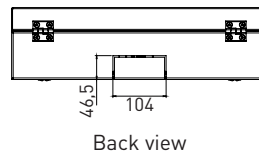
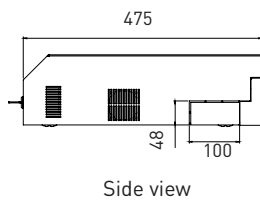
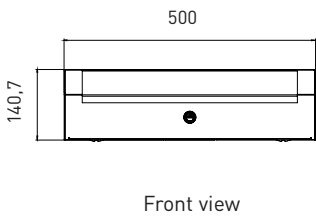
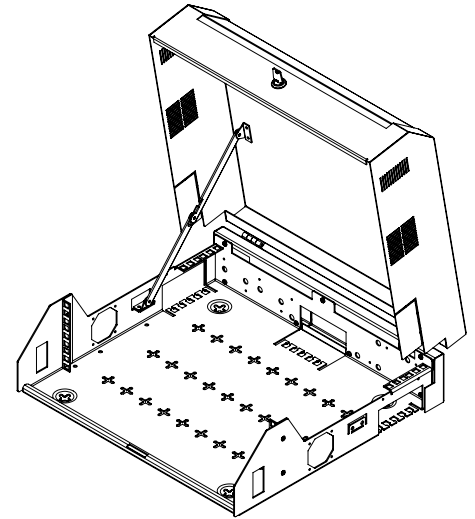
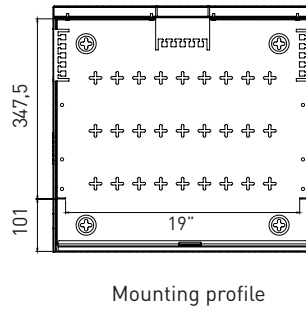
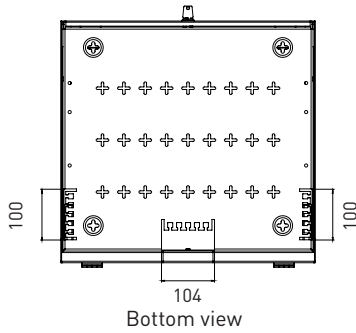

H= Enclosure height

PRODUCT REFERENCE	DEFINITION	U SIZE	WIDTH OVERALL (MM)	DEPTH OVERALL (MM)	HEIGHT VERTICAL (MM)
SLM007_01M50	19" wall mounting cabinets 5U: 3U+2U	5	500	475	140

Note: Color code "M50" is RAL 9005 black, "M2" RAL 7035 light grey option is available.

TESTS AND COMPLIED STANDARDS

TESTS AND COMPLIED STANDARDS

- 1) ISO 9001:2015 Quality Management System
- 2) ISO 14001:2015 Environmental Management System
- 3) ISO 27001:2013 Information Security Management System
- 4) ISO 45001:2018 Occupational Health and Safety Management System
- 5) 19" device mounting uprights IEC 297-1
- 6) EN 61587-1 Mechanical structures for electronic equipment.
- 7) All cabinet sizes complies with IEC 297-2.

**RESISTANCE TO ENVIRONMENTAL CONDITIONS AND CORROSION;
STABILITY, MECHANICAL SAFETY, RESISTANCE TO STATIC, DYNAMIC
AND MECHANICAL LOADS;**

**RESISTANCE TO VIBRATION, MECHANICAL SHOCK AND IMPACT;
DEGREES OF MECHANICAL PROTECTION PROVIDED BY THE
ENCLOSURE (IP20);**

ELECTRICAL GROUNDING CONTINUITY;

FIRE AND FLAME RESISTANCE;

Have been tested according to the standard " EN 61587-1" with the normative standards: IEC 60917, IEC 60297, IEC 60068-1, IEC 60068-2, IEC 60695-11-10, IEC 60950-1, contained and certified by the notified organizations::

TSE CERTIFICATE NO

003788-TSE-08/02

EAC CERTIFICATE NO

0443637, 0776963, 0345864, 0401678, 0776653

CORROSION

ISO 9227 Standard complied by the test report METALTEK AB-0547-T / 0157-1

TRANSPORT

ETS 300 019-1-2 Class 2.3 Comply with internal testing

STORAGE

ETS 300 019-1-1 Class 1.2 Comply with internal testing

SURFACE FINISH

Electrostatic powder coated c/with surface treatment , 80 +/- 5 micron paint thickness

PURCHASED PRODUCT CERTIFICATION

SHEET STEEL

EN 10346: 20015 DX51D+Z, EN 10130: 2006 DC01

ELECTROSTATIC POWDER COATING

ISO6860, ISO2409, ISO1520, ISO2815, ISO6272, ISO7253, ISO6270-1, ISO2812

ISO 9001, RoHS

GLASS

TS EN 12150-1, TS EN 1863-1

LOCK

IEC 62474, REACH, RoHS

CASTORS

ISO 9001, TS EN 12532, RoHS

FAN

IEC 60335-2-80:2002, IEC 60335-1:2010



GuardLine

Intro

IP66 Guardline 19" cabinets provide high protection against dash, corrosion, dust, vandalism, electromagnetic radiation and unfavorable weather conditions like heat, cold, rain, snow and wind.



PLINTH TYPE

GENERAL CHARACTERISTICS

- Three type of cabinets;
Plint type, wall type, pole type
- 7U, 9U, 12U, 16U, 18U, 20U, 22U, 24U height options
- 600 width, 450 and 600mm depth options
- All sizes manufactured in accordance with the standard IEC 60297
- Other size customizations available as per the customer requirements
- 450 kg. load carrying capacity (for wall mounted installation)
- Solid and durable structure
- Single and double skin options
- Anti-vandalism design
- Front door can be opened up to 125°
- 2 or 3 point locking options
- Thermostat and heater options
- Dust and water penetration blocked due to protection grades IP66 in accordance with the standard EN60529
- Fire resistant monoblock structure



High Protection for Technological Investments,

GuardLine cabinets protect your valuable and sensitive equipments with the developed wall, pole and plinth type designs.

GENERAL CHARACTERISTICS

- Polyurethane gasket providing IP66 degree of protection for all outdoor surfaces
- Available holes on the structure to install 1 or 2 fan module
- Fan & filter enabled for IP66 protection class
- Partially louvered doors equipped with filter type fresh air inlets and hot air outlets for passive ventilation
- Light Grey (RAL7035) epoxy polyester electrostatic powder painting, fire retardant
- Premium materials are providing necessary tightness and protection against contact, foreign agents and water in accordance with the standard EN 61587-1 / 6.4 IEC 60529
- Galvanized sheet steel DX51D (1.0226) +Z 275 as a standard. Stainless steel and aluminum options available
- Single or Double skin options for optimization of protection, weight and cost
- The single skin cabinet can be turned into a double skin structure when needed in the field
- The wall mounted cabinet can turned into a plinth type cabinet by supplying a plinth



WALL TYPE



POLE TYPE

GuardLine

SINGLE SKIN WALL-MOUNTED OUTDOOR CABINETS

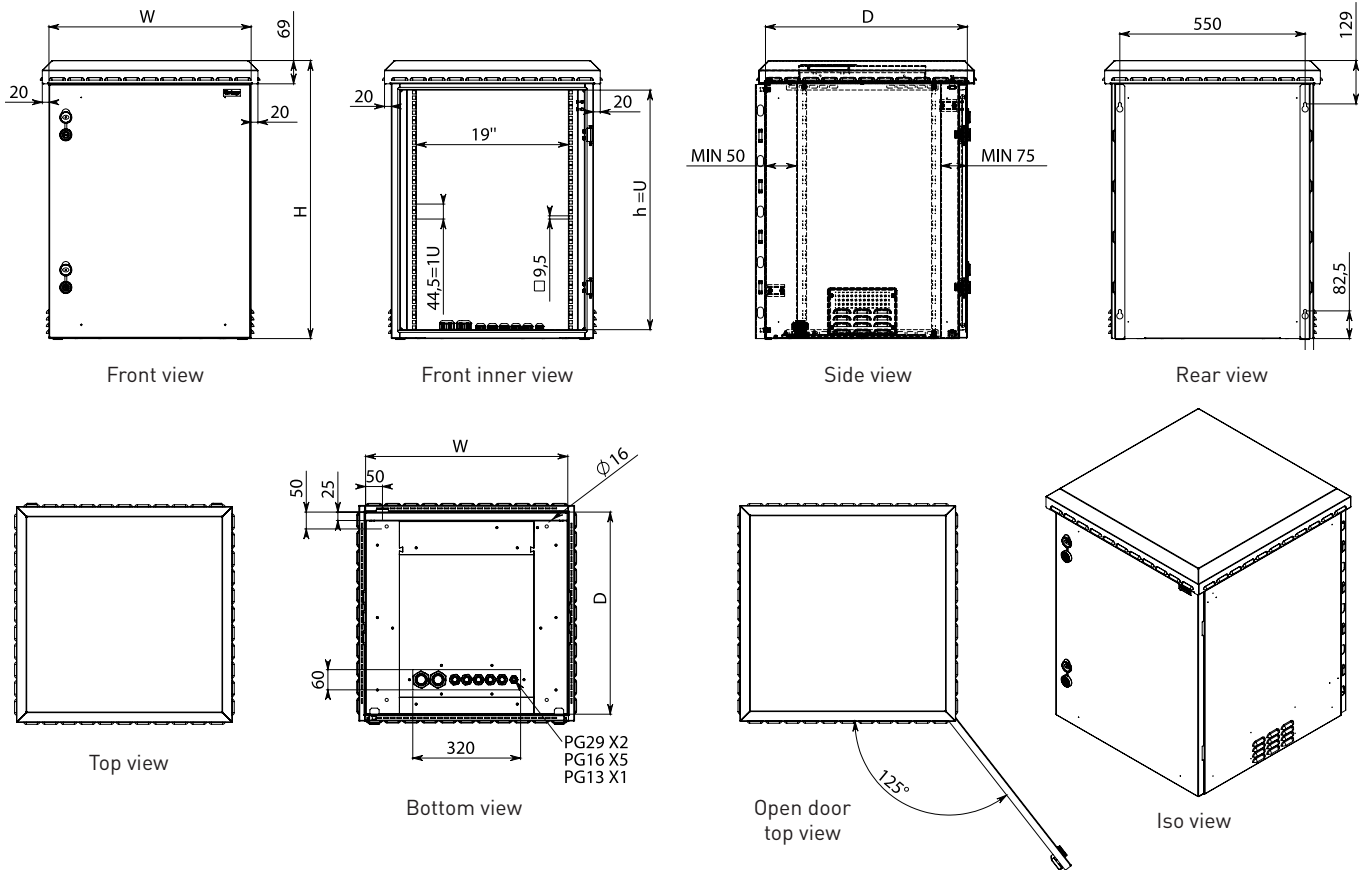

PRODUCT REFERENCE	Product Description	Dimensions WxDxH (mm)	U size	Height: Vertical mounting profile (mm)	Height: without leveling feet and casters	Width (mm)	Width; between mounting rails	Depth (mm)	Depth, between mounting rails
EOC6045T7UD_GLV_01M59	7U, 19" Single skin type outdoor cabinet	600x450x425	7U	311	425	640	19"	490	375
EOC6045T9UD_GLV_01M59	9U, 19", Single skin type outdoor cabinet	600x450x515	9U	400	515	640	19"	490	375
EOC6045T12UD_GLV_01M59	12U, 19", Single skin type outdoor cabinet	600x450x648	12U	533	648	640	19"	490	375
EOC6045T16UD_GLV_01M59	16U, 19", Single skin type outdoor cabinet	600x450x825	16U	711	825	640	19"	490	375
EOC6045T18UD_GLV_01M59	18U, 19", Single skin type outdoor cabinet	600x450x915	18U	800	915	640	19"	490	375
EOC6045T20UD_GLV_01M59	20U, 19", Single skin type outdoor cabinet	600x450x1004	20U	889	1004	640	19"	490	375
EOC6045T22UD_GLV_01M59	22U, 19", Single skin type outdoor cabinet	600x450x1092	22U	978	1092	640	19"	490	375
EOC6045T24UD_GLV_01M59	24U, 19", Single skin type outdoor cabinet	600x450x1181	24U	1067	1181	640	19"	490	375
EOC6060T7UD_GLV_01M59	7U, 19", Single skin type outdoor cabinet	600x600x425	7U	311	425	640	19"	640	525
EOC6060T9UD_GLV_01M59	9U, 19", Single skin type outdoor cabinet	600x600x515	9U	400	515	640	19"	640	525
EOC6060T12UD_GLV_01M59	12U, 19", Single skin type outdoor cabinet	600x600x648	12U	533	648	640	19"	640	525
EOC6060T16UD_GLV_01M59	12U, 19", Single skin type outdoor cabinet	600x600x825	16U	711	825	640	19"	640	525
EOC6060T18UD_GLV_01M59	18U, 19", Single skin type outdoor cabinet	600x600x915	18U	800	915	640	19"	640	525
EOC6060T20UD_GLV_01M59	20U, 19", Single skin type outdoor cabinet	600x600x1004	20U	889	1004	640	19"	640	525
EOC6060T22UD_GLV_01M59	22U, 19", Single skin type outdoor cabinet	600x600x1092	22U	978	1092	640	19"	640	525
EOC6060T24UD_GLV_01M59	24U, 19", Single skin type outdoor cabinet	600x600x1181	24U	1067	1181	640	19"	640	525

DOUBLE SKIN WALL-MOUNTED OUTDOOR CABINETS

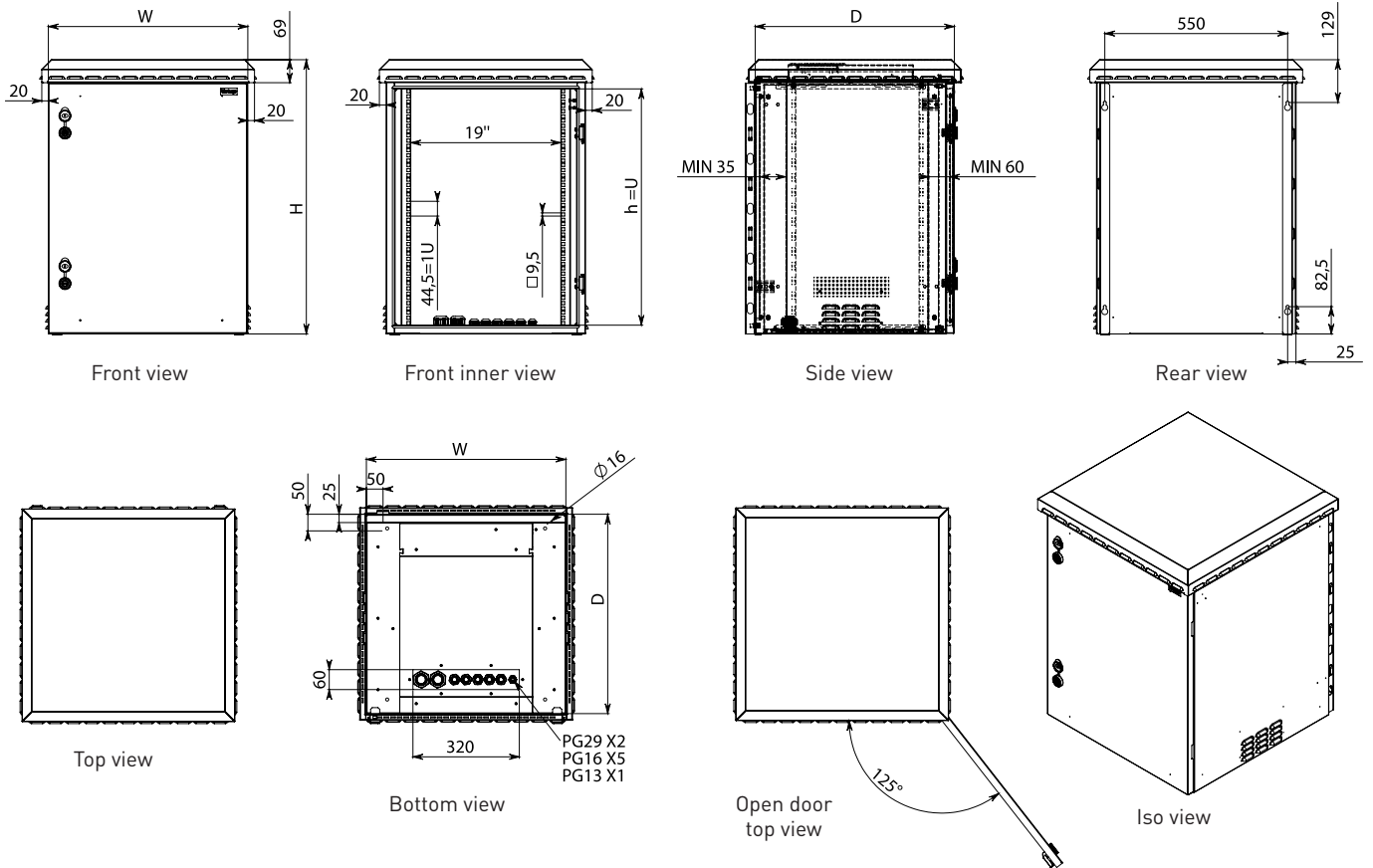

PRODUCT REFERENCE	Product Description	Dimensions WxDxH (mm)	U size	Height: Vertical mounting profile (mm)	Height: without leveling feet and casters	Width (mm)	Width; between mounting rails	Depth (mm)	Depth, between mounting rails
EOC6045C7UD_GLV_01M59	7U, 19", Double skin type outdoor cabinet	600x450x425	7U	311	425	640	19"	490	375
EOC6045C9UD_GLV_01M59	9U, 19", Double skin type outdoor cabinet	600x450x515	9U	400	515	640	19"	490	375
EOC6045C12UD_GLV_01M59	12U, 19", Double skin type outdoor cabinet	600x450x648	12U	533	648	640	19"	490	375
EOC6045C16UD_GLV_01M59	16U, 19", Double skin type outdoor cabinet	600x450x825	16U	711	825	640	19"	490	375
EOC6045C18UD_GLV_01M59	18U, 19", Double skin type outdoor cabinet	600x450x915	18U	800	915	640	19"	490	375
EOC6045C20UD_GLV_01M59	20U, 19", Double skin type outdoor cabinet	600x450x1004	20U	889	1004	640	19"	490	375
EOC6045C22UD_GLV_01M59	22U, 19", Double skin type outdoor cabinet	600x450x1092	22U	978	1092	640	19"	490	375
EOC6045C24UD_GLV_01M59	24U, 19", Double skin type outdoor cabinet	600x450x1181	24U	1067	1181	640	19"	490	375
EOC6060C7UD_GLV_01M59	7U, 19", Double skin type outdoor cabinet	600x600x425	7U	311	425	640	19"	640	525
EOC6060C9UD_GLV_01M59	9U, 19", Double skin type outdoor cabinet	600x600x515	9U	400	515	640	19"	640	525
EOC6060C12UD_GLV_01M59	12U, 19", Double skin type outdoor cabinet	600x600x648	12U	533	648	640	19"	640	525
EOC6060C16UD_GLV_01M59	16U, 19", Double skin type outdoor cabinet	600x600x825	16U	711	825	640	19"	640	525
EOC6060C18UD_GLV_01M59	18U, 19", Double skin type outdoor cabinet	600x600x915	18U	800	915	640	19"	640	525
EOC6060C20UD_GLV_01M59	20U, 19", Double skin type outdoor cabinet	600x600x1004	20U	889	1004	640	19"	640	525
EOC6060C22UD_GLV_01M59	22U, 19", Double skin type outdoor cabinet	600x600x1092	22U	978	1092	640	19"	640	525
EOC6060C24UD_GLV_01M59	24U, 19", Double skin type outdoor cabinet	600x600x1181	24U	1067	1181	640	19"	640	525

GuardLine

SINGLE SKIN PLINTH TYPE OUTDOOR CABINETS

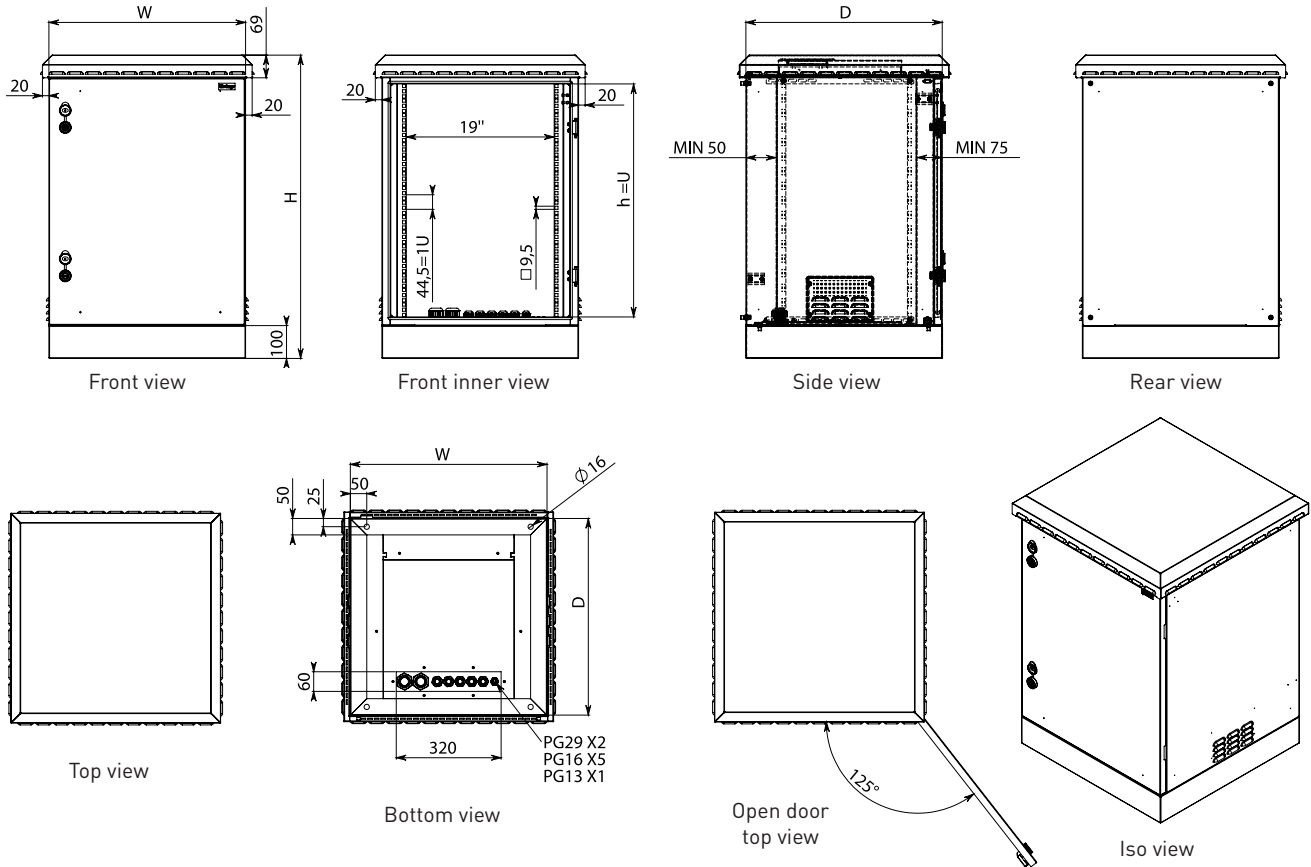

PRODUCT REFERENCE	Product Description	Dimensions WxDxH (mm)	U size	Height: Vertical mounting profile (mm)	Height: without leveling feet and casters	Width (mm)	Width; between mounting rails	Depth (mm)	Depth, between mounting rails
EOC6045T7UZ_GLV_01M59	7U, 19", Single skin type outdoor cabinet	600x450x525	7U	311	525	640	19"	490	375
EOC6045T9UZ_GLV_01M59	9U, 19", Single skin type outdoor cabinet	600x450x615	9U	400	615	640	19"	490	375
EOC6045T12UZ_GLV_01M59	12U, 19", Single skin type outdoor cabinet	600x450x748	12U	533	748	640	19"	490	375
EOC6045T16UZ_GLV_01M59	16U, 19", Single skin type outdoor cabinet	600x450x925	16U	711	925	640	19"	490	375
EOC6045T18UZ_GLV_01M59	18U, 19", Single skin type outdoor cabinet	600x450x1015	18U	800	1015	640	19"	490	375
EOC6045T20UZ_GLV_01M59	20U, 19", Single skin type outdoor cabinet	600x450x1104	20U	889	1104	640	19"	490	375
EOC6045T22UZ_GLV_01M59	22U, 19", Single skin type outdoor cabinet	600x450x1192	22U	978	1192	640	19"	490	375
EOC6045T24UZ_GLV_01M59	24U, 19", Single skin type outdoor cabinet	600x450x1281	24U	1067	1281	640	19"	490	375
EOC6060T7UZ_GLV_01M59	7U, 19", Single skin type outdoor cabinet	600x600x525	7U	311	525	640	19"	640	525
EOC6060T9UZ_GLV_01M59	9U, 19", Single skin type outdoor cabinet	600x600x615	9U	400	615	640	19"	640	525
EOC6060T12UZ_GLV_01M59	12U, 19", Single skin type outdoor cabinet	600x600x748	12U	533	748	640	19"	640	525
EOC6060T16UZ_GLV_01M59	12U, 19", Single skin type outdoor cabinet	600x600x925	16U	711	925	640	19"	640	525
EOC6060T18UZ_GLV_01M59	18U, 19", Single skin type outdoor cabinet	600x600x1015	18U	800	1015	640	19"	640	525
EOC6060T20UZ_GLV_01M59	20U, 19", Single skin type outdoor cabinet	600x600x1104	20U	889	1104	640	19"	640	525
EOC6060T22UZ_GLV_01M59	22U, 19", Single skin type outdoor cabinet	600x600x1192	22U	978	1192	640	19"	640	525
EOC6060T24UZ_GLV_01M59	24U, 19", Single skin type outdoor cabinet	600x600x1281	24U	1067	1281	640	19"	640	525

DOUBLE SKIN PLINTH TYPE OUTDOOR CABINETS

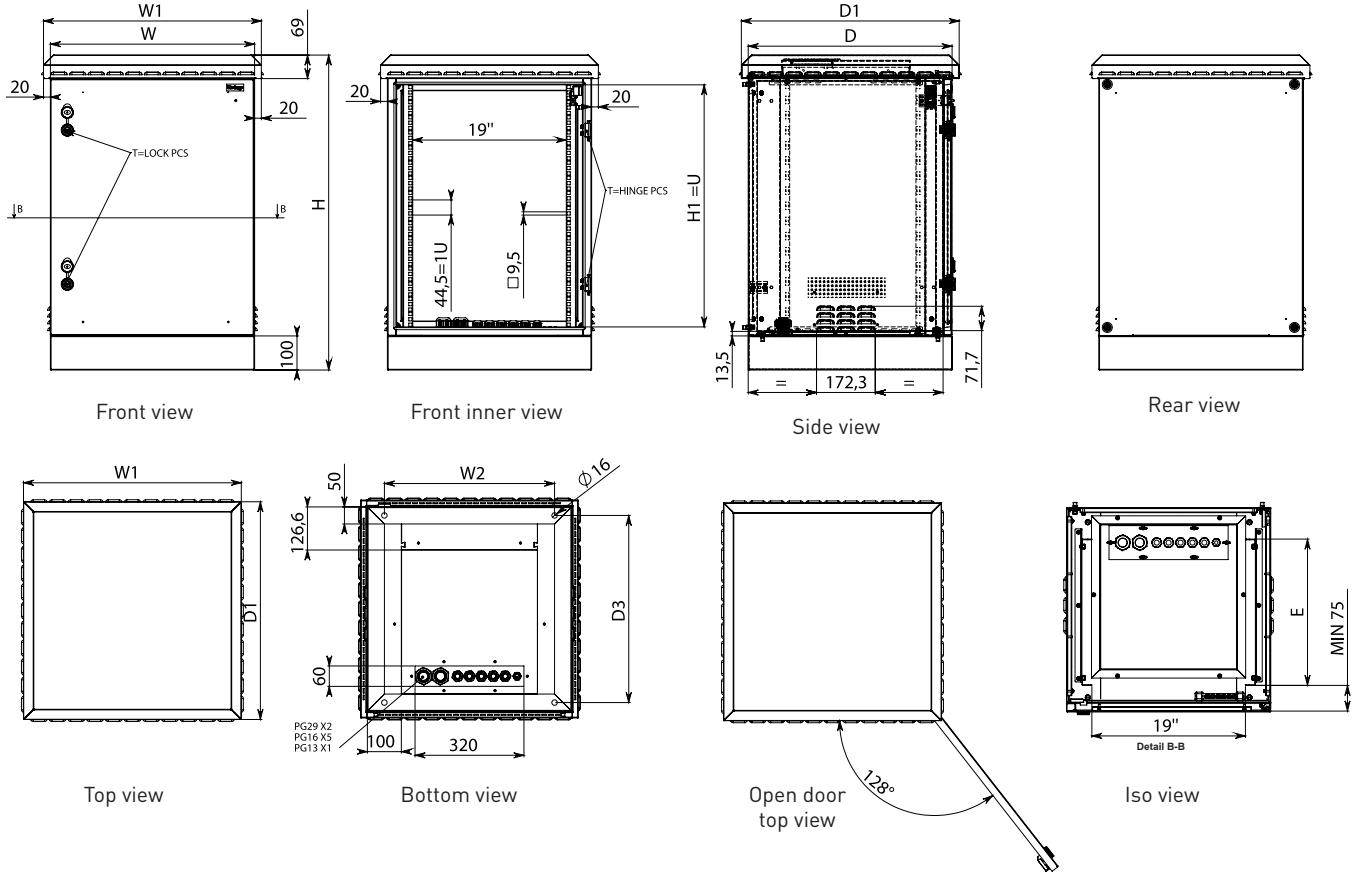

PRODUCT REFERENCE	Product Description	Dimensions WxDxH (mm)	U size	Height: Vertical mounting profile (mm)	Height: without leveling feet and casters	Width (mm)	Width; between mounting rails	Depth (mm)	Depth, between mounting rails
EOC6045C7UZ_GLV_01M59	7U, 19", Double skin type outdoor cabinet	600x450x525	7U	311	525	640	19"	490	375
EOC6045C9UZ_GLV_01M59	9U, 19", Double skin type outdoor cabinet	600x450x615	9U	400	615	640	19"	490	375
EOC6045C12UZ_GLV_01M59	12U, 19", Double skin type outdoor cabinet	600x450x748	12U	533	748	640	19"	490	375
EOC6045C16UZ_GLV_01M59	16U, 19", Double skin type outdoor cabinet	600x450x925	16U	711	925	640	19"	490	375
EOC6045C18UZ_GLV_01M59	18U, 19", Double skin type outdoor cabinet	600x450x1015	18U	800	1015	640	19"	490	375
EOC6045C20UZ_GLV_01M59	20U, 19", Double skin type outdoor cabinet	600x450x1104	20U	889	1104	640	19"	490	375
EOC6045C22UZ_GLV_01M59	22U, 19", Double skin type outdoor cabinet	600x450x1192	22U	978	1192	640	19"	490	375
EOC6045C24UZ_GLV_01M59	24U, 19", Double skin type outdoor cabinet	600x450x1281	24U	1067	1281	640	19"	490	375
EOC6060C7UZ_GLV_01M59	7U, 19", Double skin type outdoor cabinet	600x600x525	7U	311	525	640	19"	640	525
EOC6060C9UZ_GLV_01M59	9U, 19", Double skin type outdoor cabinet	600x600x615	9U	400	615	640	19"	640	525
EOC6060C12UZ_GLV_01M59	12U, 19", Double skin type outdoor cabinet	600x600x748	12U	533	748	640	19"	640	525
EOC6060C16UZ_GLV_01M59	12U, 19", Double skin type outdoor cabinet	600x600x925	16U	711	925	640	19"	640	525
EOC6060C18UZ_GLV_01M59	18U, 19", Double skin type outdoor cabinet	600x600x1015	18U	800	1015	640	19"	640	525
EOC6060C20UZ_GLV_01M59	20U, 19", Double skin type outdoor cabinet	600x600x1104	20U	889	1104	640	19"	640	525
EOC6060C22UZ_GLV_01M59	22U, 19", Double skin type outdoor cabinet	600x600x1192	22U	978	1192	640	19"	640	525
EOC6060C24UZ_GLV_01M59	24U, 19", Double skin type outdoor cabinet	600x600x1281	24U	1067	1281	640	19"	640	525

GuardLine Accessories

POWER DISTRIBUTION PANEL

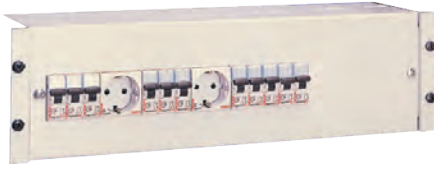

PRODUCT REFERENCE	DESCRIPTION	DIMENSIONS (WxDxH)	D=450 (mm)	D=600 (mm)
M68DCD3U_01M50	3U, 19" power distribution panel with grounding bar	483x123x133	x	x

PHONE DISTRIBUTION PANEL

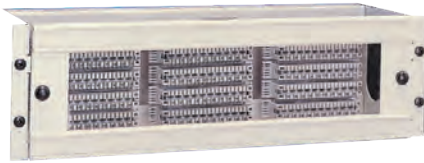

PRODUCT REFERENCE	DESCRIPTION	DIMENSIONS (WxDxH)	D=450 (mm)	D=600 (mm)
M68TLD3U_01M50	3U, 19" Phone distribution panel	483x150x139	x	x

RACK MOUNT SHELF



PRODUCT REFERENCE	DESCRIPTION	DIMENSIONS (WxDxH)	D=450 (mm)	D=600 (mm)
E44RAK20M50KFS	19", 1U shelf, depth= 200 mm	483x200x44	x	x
E44RAK25M50KFS	19", 1U shelf, depth= 250 mm	483x250x44	x	x
E44RAK30M50KFS	19", 1U shelf, depth= 300 mm	483x300x44	x	x
E44RAK35M50KFS	19", 2U shelf, depth= 350 mm	483x370x88	x	x
E44RAK40M50KFS	19", 1U shelf, depth= 400 mm	483x400x43	x	x

FIXED AND SLIDING SHELVES

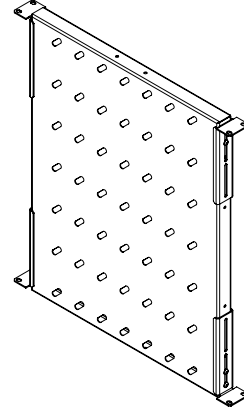

PRODUCT REFERENCE			Distance between uprights	
			Min. (A) (mm)	Max. (B) (mm)
SHLFIX60M50	D= 600 mm fixed shelf module with slots / load capacity 50 kg. / Ral...	Depth of the shelf D= 372 mm, 4-points fixed. only suitable for 600 mm depth cabinets. Load carrying capacity is 50 kg.	355	500

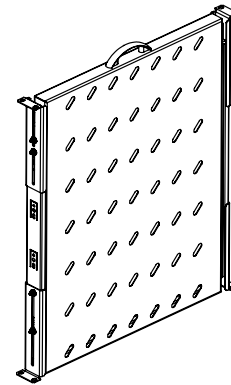

PRODUCT REFERENCE			Distance between uprights	
			Min. (A) (mm)	Max. (B) (mm)
SHLSLD60M50	D= 600 mm sliding shelf module with slots / load capacity 30 kg. / Ral...	Depth of the shelf D= 372 mm, 4-points fixed. only suitable for 600 mm depth cabinets. Load carrying capacity is 30 kg.	337	500

Note: Color code "M50" is RAL 9005 black, "M2" RAL 7035 light grey option is available.

GuardLine Accessories

FRONT DOOR MODULES

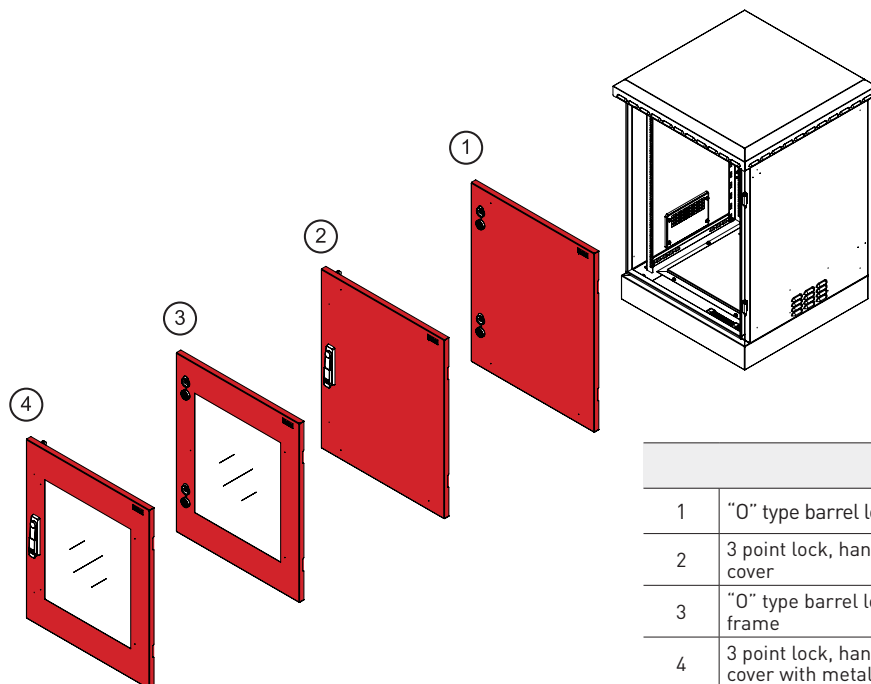

PRODUCT DETAILS	
1	"O" type barrel locking mechanism, metal front cover
2	3 point lock, handle with semi cylindrical barrel, metal front cover
3	"O" type barrel locking mechanism, glass front cover with metal frame
4	3 point lock, handle with semi cylindrical barrel, glass front cover with metal frame

PRODUCT REFERENCE	PRODUCT DESCRIPTION	Dimensions WxDxH (mm)
M350KPK607C	7U, W=600, Double skin, Metal front cover, "O" type 1 point locking mechanism	598x352,95x23
M350KPK609C	9U, W=600, Double skin, Metal front cover "O" type 2 point locking mechanism	598x441,85x23
M350KPK612C	12U, W=600, Double skin, Metal front cover "O" type 2 point locking mechanism	598x575,2x23
M350KPK616C	16U, W=600, Double skin, Metal front cover "O" type 2 point locking mechanism	598x753x23
M350KPK618C	18U, W=600, Double skin, Metal front cover "O" type 3 point locking mechanism	598x841,9x23
M350KPK620C	20U, W=600, Double skin, Metal front cover "O" type 3 point locking mechanism	598x930,8x23
M350KPK622C	22U, W=600, Double skin, Metal front cover "O" type 3 point locking mechanism	598x1019,7x23
M350KPK624C	24U, W=600, Double skin, Metal front cover "O" type 3 point locking mechanism	598x1108x23
M350KPK607T	7U, W=600, Single skin, Metal front cover, "O" type 1 point locking mechanism	598x352,95x23
M350KPK609T	9U, W=600, Single skin, Metal front cover, "O" type 2 point locking mechanism	598x441,85x23
M350KPK612T	12U, W=600, Single skin, Metal front cover, "O" type 2 point locking mechanism	598x575,2x23
M350KPK616T	16U, W=600, Single skin, Metal front cover, "O" type 2 point locking mechanism	598x753x23
M350KPK618T	18U, W=600, Single skin, Metal front cover "O" type 3 point locking mechanism	598x841,9x23
M350KPK620T	20U, W=600, Double skin, Metal front cover "O" type 3 point locking mechanism	598x930,8x23
M350KPK622T	22U, W=600, Double skin, Metal front cover "O" type 3 point locking mechanism	598x1019,7x23
M350KPK624T	24U, W=600, Double skin, Metal front cover "O" type 3 point locking mechanism	598x1108x23
M350KPK618CK	18U, W=600, Double skin, Metal front cover 3 point lock, handle with semi cylindrical barrel	598x841,9x23
M350KPK620CK	20U, W=600, Double skin, Metal front cover 3 point lock, handle with semi cylindrical barrel	598x930,8x23
M350KPK622CK	22U, W=600, Double skin, Metal front cover 3 point lock, handle with semi cylindrical barrel	598x1019,7x23
M350KPK624CK	24U, W=600, Double skin, Metal front cover 3 point lock, handle with semi cylindrical barrel	598x1108x23
M350KPK618TK	18U, W=600, Single skin, Metal front cover 3 point lock, handle with semi cylindrical barrel	598x841,9x23
M350KPK620TK	20U, W=600, Single skin, Metal front cover 3 point lock, handle with semi cylindrical barrel	598x930,8x23
M350KPK622TK	22U, W=600, Single skin, Metal front cover 3 point lock, handle with semi cylindrical barrel	598x1019,7x23
M350KPK624TK	24U, W=600, Single skin, Metal front cover 3 point lock, handle with semi cylindrical barrel	598x1108x23

GuardLine Accessories

INTERNAL SKIN MODULE

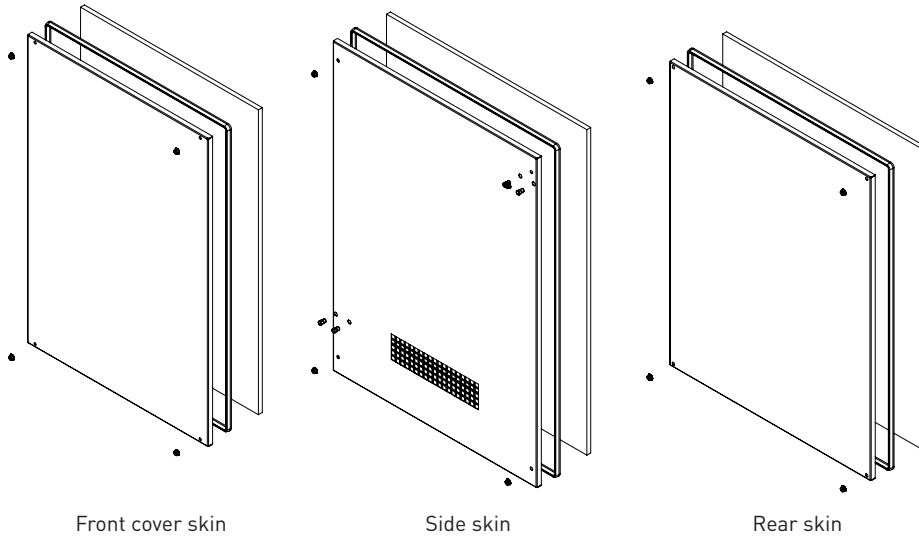

PRODUCT REFERENCE	PRODUCT DESCRIPTION	Dimensions WxDxH (mm)
M350AKCDR609_01M59	9U,W=600, Outdoor cabinet front and rear skin module	520 x 12 x 369
M350AKCDR612_01M59	12U,W=600, Outdoor cabinet front and rear skin module	520 x 12 x 502
M350AKCDR616_01M59	16U,W=600, Outdoor cabinet front and rear skin module	520 x 12 x 680
M350AKCDR618_01M59	18U,W=600, Outdoor cabinet front and rear skin module	520 x 12 x 768,9
M350AKCDR620_01M59	20U,W=600, Outdoor cabinet front and rear skin module	520 x 12 x 857,8
M350AKCDR622_01M59	22U,W=600, Outdoor cabinet front and rear skin module	520 x 12 x 946,7
M350AKCDR624_01M59	24U,W=600, Outdoor cabinet front and rear skin module	520 x 12 x 1035,6
M350YNCDR64507_01M59	7U, W=450, Outdoor cabinet side skin module	370 x 12 x 280
M350YNCDR64509_01M59	9U, W=450, Outdoor cabinet side skin module	370 x 12 x 369
M350YNCDR64512_01M59	12U, W=450, Outdoor cabinet side skin module	370 x 12 x 502
M350YNCDR64516_01M59	16U, W=450, Outdoor cabinet side skin module	370 x 12 x 680
M350YNCDR64518_01M59	18U, W=450, Outdoor cabinet side skin module	370 x 12 x 768,9
M350YNCDR64520_01M59	20U, W=450, Outdoor cabinet side skin module	370 x 12 x 857,8
M350YNCDR64522_01M59	22U, W=450, Outdoor cabinet side skin module	370 x 12 x 946,7
M350YNCDR64524_01M59	24U, W=450, Outdoor cabinet side skin module	370 x 12 x 1035,6
M350YNCDR6607_01M59	7U, W=600, Outdoor cabinet side skin module	520 x 12 x 280
M350YNCDR6609_01M59	9U, W=600, Outdoor cabinet side skin module	520 x 12 x 369
M350YNCDR6612_01M59	12U, W=600, Outdoor cabinet side skin module	520 x 12 x 502
M350YNCDR6616_01M59	16U, W=600, Outdoor cabinet side skin module	520 x 12 x 680
M350YNCDR6618_01M59	18U, W=600, Outdoor cabinet side skin module	520 x 12 x 768,9
M350YNCDR6620_01M59	20U, W=600, Outdoor cabinet side skin module	520 x 12 x 857,8
M350YNCDR6622_01M59	22U, W=600, Outdoor cabinet side skin module	520 x 12 x 946,7
M350YNCDR6624_01M59	24U, W=600, Outdoor cabinet side skin module	520 x 12 x 1035,6

GuardLine Accessories

HORIZONTAL CABLE MANAGER

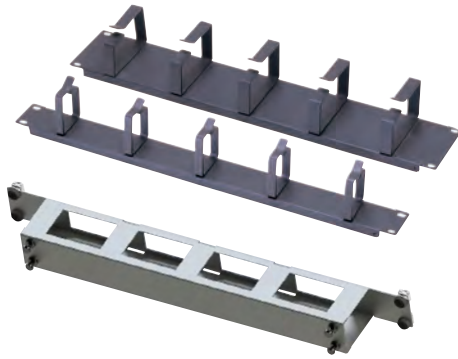

PRODUCT REFERENCE	DESCRIPTION	DIMENSIONS (WxDxH)	D=450 (mm)	D=600 (mm)
E440RG1U_01M50	1U 19" cable management panels with 5 metal rings	483x80x44	x	x
E440RG2U_01M50	2U 19" cable management panels with 5 metal rings	483x80x88	x	x
E440RG1UN_01M50	1U 19" cable management panel, channel type and with removable cover	483x80x44	x	x

BLANK PANELS



PRODUCT REFERENCE	DESCRIPTION	DIMENSIONS (WxDxH)	D=450 (mm)	D=600 (mm)
E44BPN01_01M50	1U, 19" Blank panel	483x44x12	x	x
E44BPN02_01M50	2U, 19" Blank panel	483x88x12	x	x
E44BPN03_01M50	3U, 19" Blank panel	483x133x12	x	x
E44BPN04_01M50	4U, 19" Blank panel	483x177x12	x	x
E44BPN05_01M50	5U, 19" Blank panel	483x222x12	x	x
E44BPN06_01M50	6U, 19" Blank panel	483x266x12	x	x
P44BPN06_01M50	6U, 19" Modular blank plastic panel (ABS)	483x266x12	x	x

CABLE TRAYS

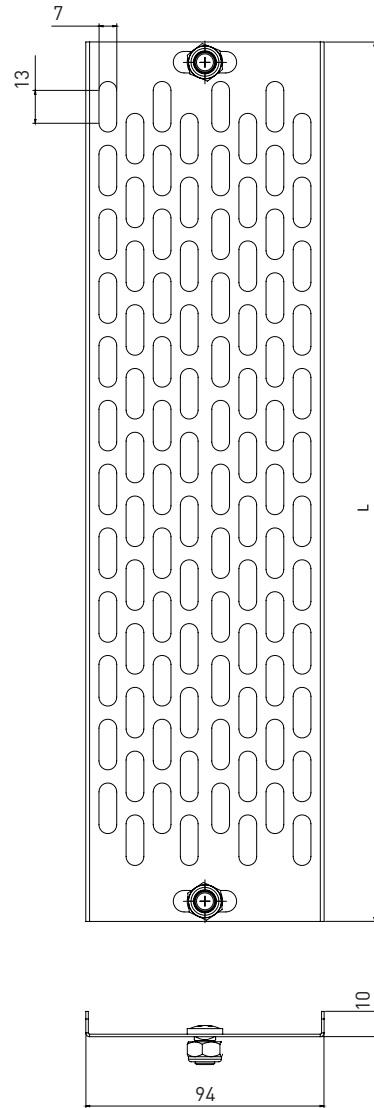

PRODUCT REFERENCE	DESCRIPTION	DIMENSIONS (WxDxH)
M350KNL07	7U, Outdoor cabinets 94 mm Cable Tray	94x14x311
M350KNL09	9U, Outdoor cabinets 94 mm Cable Tray	94x14x400
M350KNL12	12U, Outdoor cabinets 94 mm Cable Tray	94x14x533,4
M350KNL16	16U, Outdoor cabinets 94 mm Cable Tray	94x14x711
M350KNL18	18U, Outdoor cabinets 94 mm Cable Tray	94x14x800
M350KNL20	20U, Outdoor type cabinet 94 mm Cable Tray	94x14x889
M350KNL22	22U, Outdoor type cabinet 94 mm Cable Tray	94x14x978
M350KNL24	24U, Outdoor type cabinet 94 mm Cable Tray	94x14x1066,8

GuardLine Accessories

FAN MODULE

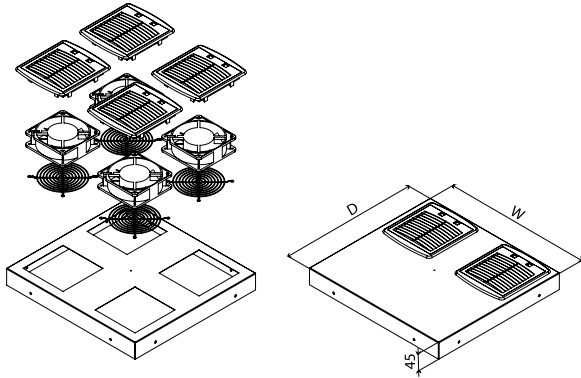

PRODUCT REFERENCE	DESCRIPTION	DIMENSIONS (WxDxH)	D=450 (mm)	D=600 (mm)
M44HV6452HVT_01M59	600X450 Outdoor cabinet 2 fan + filter thermostat - RAL 7035 T	403x227x45	x	
M44HV662HVT_01M59	600X600 Outdoor cabinet 2 fan + filter thermostat - RAL 7035 T	403x377x45		x
M44HV664HVT_01M59	600X600 Outdoor cabinet 4 fan + filter thermostat - RAL 7035 T	403x377x45		x
M44HV6452HV_01M59	600X450 Outdoor cabinet 2 fan + filter - RAL 7035 T	403x227x45	x	
M44HV662HV_01M59	600X600 Outdoor cabinet 2 fan + filter - RAL 7035 T	403x377x45		x
M44HV664HV_01M59	600X600 Outdoor cabinet 4 fan + filter - RAL 7035 T	403x377x45		x
M44HVPNLK645_01M59	600X450 Outdoor cabinet top blank cover - RAL 7035 T	403x227x45	x	
M44HVPNLK66_01M59	600X600 Outdoor cabinet top blank cover - RAL 7035 T	403x377x45		x
TERMOSTAT3	30 degree thermostat module can be mounted on circuit breaker rail	25x28x50		

PLINTH

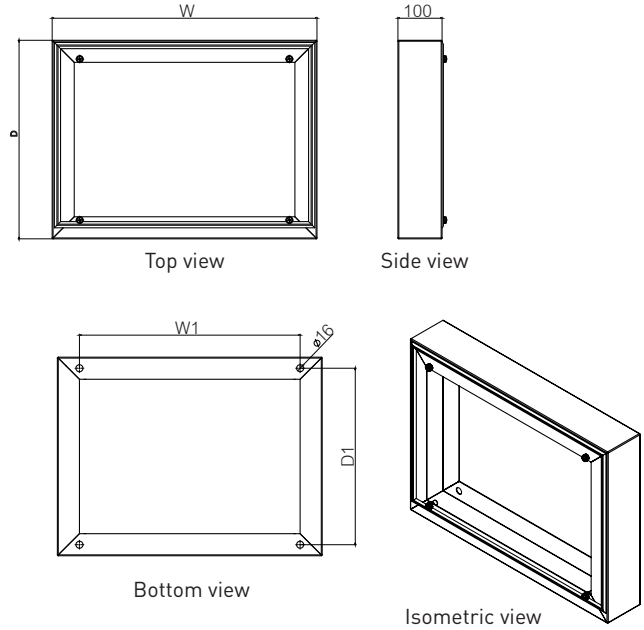

PRODUCT REFERENCE	DESCRIPTION	DIMENSIONS (WxDxH)	D=450 (mm)	D=600 (mm)
M350BZ0566_01M59	Plinth width=600mm; depth=600mm; height=50mm, Outdoor cabinets	600x600x50		X
M350BZ1066_01M59	Plinth width=600 mm, depth =600 mm, height =100 mm, Outdoor cabinets	600x600x100		X
M350BZ1566_01M59	Plinth width=600 mm, depth =600 mm, height =150 mm, Outdoor cabinets	780x600x150		X
M350BZ3066_01M59	Plinth width=600 mm, depth =600 mm, height =300 mm, Outdoor cabinets	600x600x300		X
M350BZ05645_01M59	Plinth width=600 mm, depth =450 mm, height =50 mm, Outdoor cabinets	600x450x50	X	
M350BZ10645_01M59	Plinth width=600 mm, depth =450 mm, height =100 mm, Outdoor cabinets	600x450x100	X	
M350BZ15645_01M59	Plinth width=600 mm, depth =450 mm, height =150 mm, Outdoor cabinets	780x450x150	X	
M350BZ30645_01M59	Plinth width=600 mm, depth =450 mm, height =300 mm, Outdoor cabinets	600x450x300	X	

GuardLine Accessories

WALL-MOUNTED BRACKET



PRODUCT REFERENCE	DESCRIPTION	DIMENSIONS (WxDxH)	D=450 (mm)	D=600 (mm)
M350DVRAPT07_01M59	7U, Wall mount bracket	34x30x355	X	X
M350DVRAPT09_01M59	9U, Wall mount bracket	34x30x444	X	X
M350DVRAPT12_01M59	12U, Wall mount bracket	34x30x577	X	X
M350DVRAPT16_01M59	16U, Wall mount bracket	34x30x755	X	X
M350DVRAPT18_01M59	18U, Wall mount bracket	34x30x845	X	X
M350DVRAPT20_01M59	20U, Wall mount bracket	34x30x933	X	X
M350DVRAPT22_01M59	22U, Wall mount bracket	34x30x1022	X	X
M350DVRAPT24_01M59	24U, Wall mount bracket	34x30x1110	X	X

FILTER MODULE



PRODUCT REFERENCE	DESCRIPTION	DIMENSIONS (WxDxH)
M350FLTSC	Single skin, cabinet interior side filter module	200x10x150

POLE BRACKET

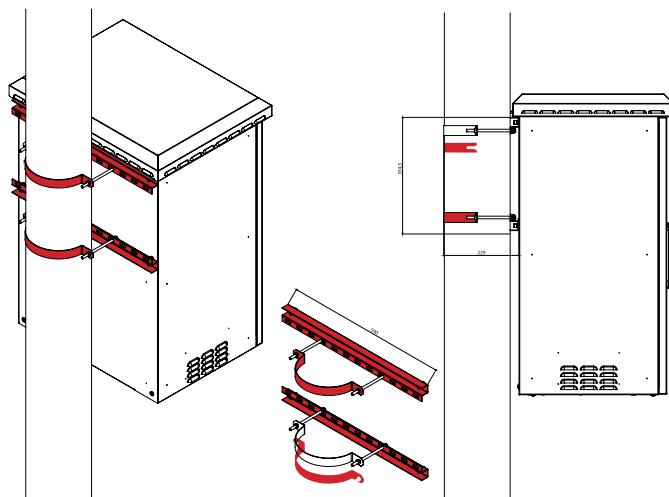

PRODUCT REFERENCE	DESCRIPTION	DIMENSIONS (WxDxH)
M350DRKAPRT_01M59	W=590, pole bracket is available all sizes	590x229x354,5

DEVICE SUPPORT KIT

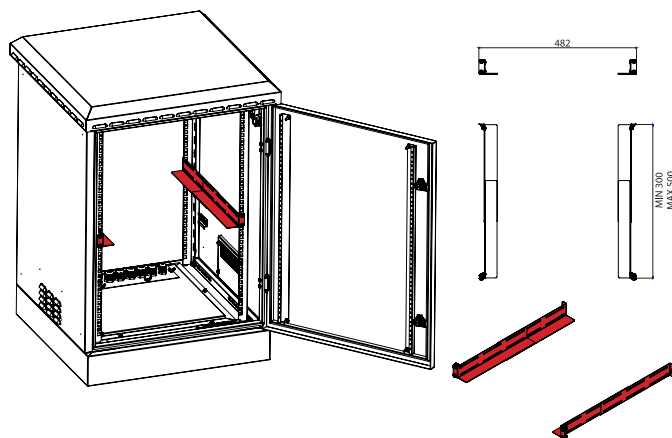

PRODUCT REFERENCE	DESCRIPTION	DIMENSIONS (WxDxH)	D=450 (mm)	D=600 (mm)
M44RLD_02MG	L type device support kit	300x60x44	X	X

GuardLine Accessories

19" UPRIGHTS

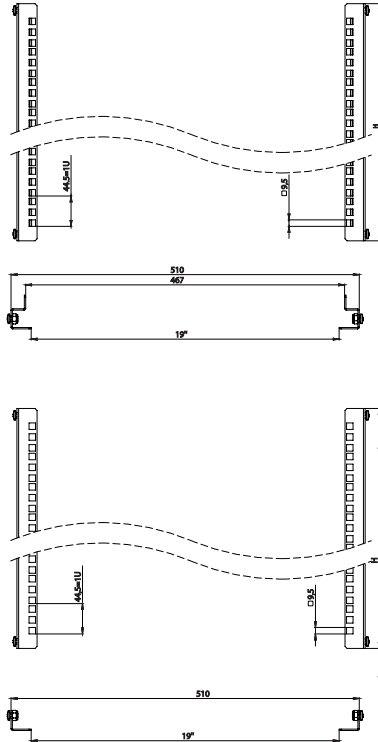

PRODUCT REFERENCE	DESCRIPTION	DIMENSIONS (WxDxH)	D=450 (mm)	D=600 (mm)
M350ACD07_01MG	7U L, 19" Uprights, 1 set=2 pcs.	29,5x29,5x350	X	X
M350ACD09_01MG	9U L, 19" Uprights, 1 set=2 pcs.	29,5x29,5x440	X	X
M350ACD12_01MG	12U L, 19" Uprights, 1 set=2 pcs.	29,5x29,5x573	X	X
M350ACD16_01MG	16U L, 19" Uprights, 1 set=2 pcs.	29,5x29,5x750	X	X
M350ACD18_01MG	18U L, 19" Uprights, 1 set=2 pcs.	29,5x29,5x840	X	X
M350ACD20_01MG	20U L, 19" Uprights, 1 set=2 pcs.	29,5x29,5x928	X	X
M350ACD22_01MG	22U L, 19" Uprights, 1 set=2 pcs.	29,5x29,5x1017	X	X
M350ACD24_01MG	24U L, 19" Uprights, 1 set=2 pcs.	29,5x29,5x1106	X	X
M350SCD07_01MG	7U, S 19" Uprights, 1 set=2 pcs.	29,5x49,5x350	X	X
M350SCD09_01MG	9U S, 19" Uprights, 1 set=2 pcs.	29,5x49,5x440	X	X
M350SCD12_01MG	12U S, 19" Uprights, 1 set=2 pcs.	29,5x49,5x573	X	X
M350SCD16_01MG	16U S, 19" Uprights, 1 set=2 pcs.	29,5x49,5x750	X	X
M350SCD18_01MG	18U S, 19" Uprights, 1 set=2 pcs.	29,5x49,5x840	X	X
M350SCD20_01MG	20U S, 19" Uprights, 1 set=2 pcs.	29,5x49,5x928	X	X
M350SCD22_01MG	22U S, 19" Uprights, 1 set=2 pcs.	29,5x49,5x1017	X	X
M350SCD24_01MG	24U S, 19" Uprights, 1 set=2 pcs.	29,5x49,5x1106	X	X

LED LIGHT MODULE



PRODUCT REFERENCE	DIMENSIONS (WxDxH)
MAYDNLED-IRM	300x25x13,5

FIXING KIT



PRODUCT REFERENCE	DESCRIPTION	DIMENSIONS (WxDxH)	D=450 (mm)	D=600 (mm)
KFS6X15_20	M6 Cage Nut, 1 set=20 pcs	9.5x9.5	X	X

GuardLine Accessories

GROUNDING KIT

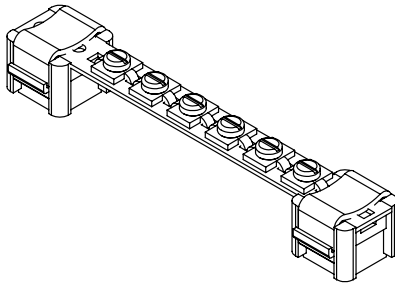
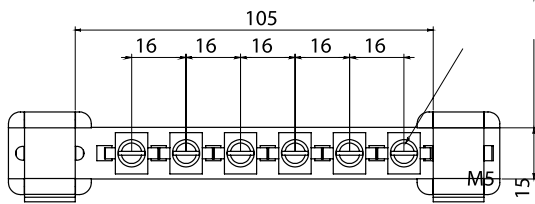
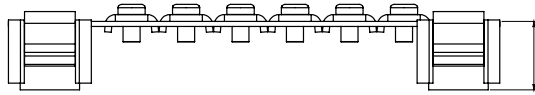

TESTS AND COMPLIED STANDARDS

TESTS AND COMPLIED STANDARDS

- 1) ISO 9001:2015 Quality Management System
- 2) ISO 14001:2015 Environmental Management System
- 3) ISO 27001:2013 Information Security Management System
- 4) ISO 45001:2018 Occupational Health and Safety Management System
- 5) 19" device mounting uprights IEC 297-1
- 6) EN 61587-1 Mechanical structures for electronic equipment.
- 7) All cabinet sizes complies with IEC 297-2.

SAFETY

**PROTECTION AGAINST EXTERNAL MECHANICAL IMPACTS;
MECHANICAL STRUCTURES (CABINETS FOR ELECTRONIC
EQUIPMENT);**

ENVIRONMENTAL TESTING COLD/DRY HEAT/DAMP HEAT

**HAVE BEEN TESTED ACCORDING TO THE STANDARD " EN 61587-1"
WITH THE NORMATIVE STANDARDS: EN 60950, IEC 62262, EN 61587-1:
2012,**

IEC 60068-2-1; IEC 60068-2-2; IEC 60068-2-30 contained within and certified by the approved institutions:

TSE CERTIFICATE NO

003788-TSE-08/02

TRANSPORT

ETS 300 019-1-2 Class 2.3

STORAGE

ETS 300 019-1-1 Class 1.2

PRODUCT REFERENCE	DESCRIPTION	DIMENSIONS (WxDxH)	D=450 (mm)	D=600 (mm)
M350BARA2_01	Grounding kit with 6 pcs. cable	2x15x150	X	X

IP55 Outdoor Cabinets

Intro

Double panelled, robust and sturdy aluminium extruded framework; Estap's outdoor enclosures designed to provide maximum protection against environmental factors, vandalism, EMC and extreme weather conditions.



GENERAL CHARACTERISTICS

- Wide range of sizes; 24U, 32U, 36U and 42U
- Depth sizes; 600 mm, 800 mm. and 1000 mm
- Width sizes; 600 mm. and 800 mm
- 1000 kg load carrying capacity
- IP 55 protection standard according to EN 60529
- 130 degree easy openable doors
- Standard colors, RAL 7035 Light Grey
- All sizes manufactured in accordance with the standard IEC 60297
- Depth adjustable 19" mounting uprights even when the cabinet is fully loaded
- Numbered U positions facilitate easy installation of rack mounted equipment
- IP55 fan & filter enabled protection class



High standards of protection

Outdoor cabinets are for use whenever maximum protection is a must.

- Maximum protection for environmental and mechanical impacts, vandalism, electromagnetic emissions and extreme thermal conditions
- Sturdy construction and quality material with concealed hinges
- Robust and solid profile technology, high performance thermal control, a natural ventilation system
- Polyurethane gasket providing IP55 degree of protection for all outdoor surfaces
- Special surface ensure anti-graffiti, anti-poster
- Light Grey (RAL7035) epoxy polyester electrostatic powder painting, fire retardant
- 3-point, swing handle door locking mechanism: high security for unauthorized access
- High technical performance; grounding continuity
- Special design and maximum volume for all vendors' devices
- Modular construction for easy installation



IP55 Outdoor Cabinets

DIMENSIONS

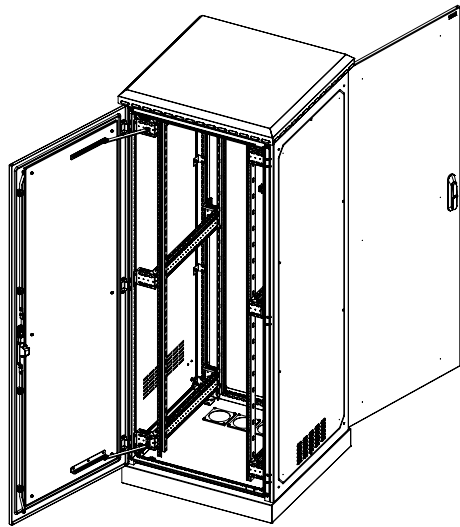

Open door isometric view

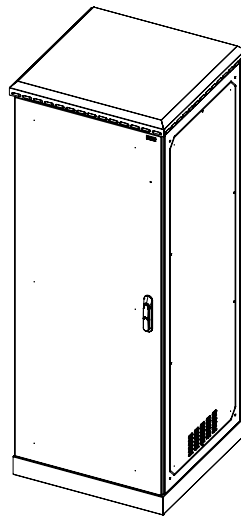

Isometric view

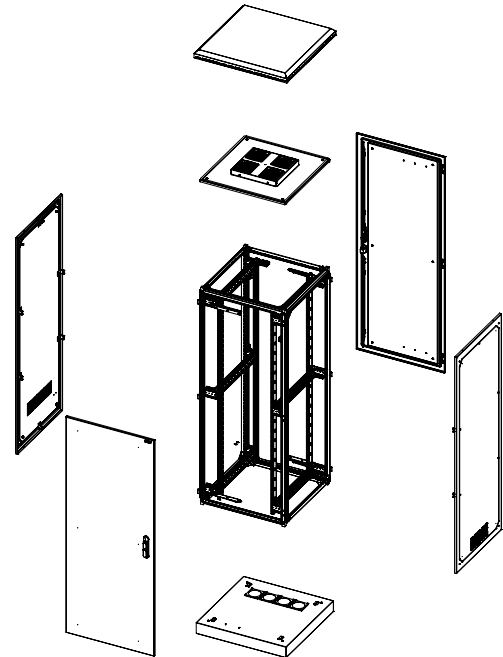

Exploded view

PRODUCT REFERENCE	DESCRIPTION	HxWxD (mm)
DCO24U6060_M59	24U 600x600 mm. IP55 outdoor cabinet RAL7035	600x1280x600
DCO24U6080_M59	24U 600x800 mm. IP55 outdoor cabinet RAL7035	600x1280x800
DCO32U6060_M59	32U 600x600 mm. IP55 outdoor cabinet RAL7035	600x1600x600
DCO32U6080_M59	32U 600x800 mm. IP55 outdoor cabinet RAL7035	600x1600x800
DCO32U8080_M59	32U 800x800 mm. IP55 outdoor cabinet RAL7035	800x1600x800
DCO36U6060_M59	36U 600x600 mm. IP55 outdoor cabinet RAL7035	600x1760x600
DCO36U6080_M59	36U 600x800 mm. IP55 outdoor cabinet RAL7035	600x1760x800
DCO36U8080_M59	36U 800x800 mm. IP55 outdoor cabinet RAL7035	800x1760x800
DCO42U6060_M59	42U 600x600 mm. IP55 outdoor cabinet RAL7035	600x2000x600
DCO42U6080_M59	42U 600x800 mm. IP55 outdoor cabinet RAL7035	600x2000x800
DCO42U6010_M59	42U 600x1000 mm. IP55 outdoor cabinet RAL7035	600x2000x1000
DCO42U8080_M59	42U 800x800 mm. IP55 outdoor cabinet RAL7035	800x2000x800
DCO42U8010_M59	42U 800x1000 mm. IP55 outdoor cabinet RAL7035	800x2000x1000

TECHNICAL DRAWINGS

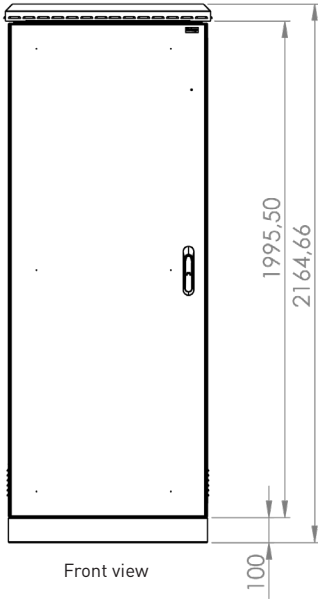

Front view

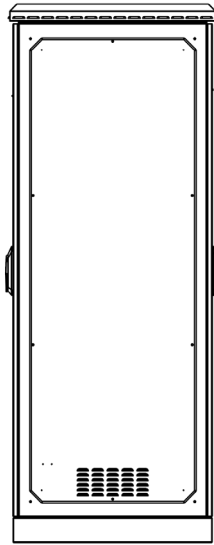

Side view

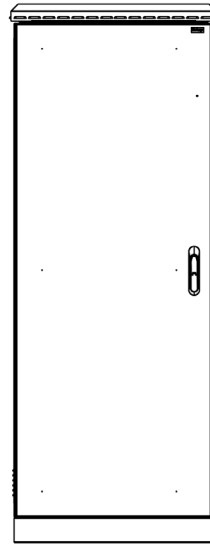

Rear view

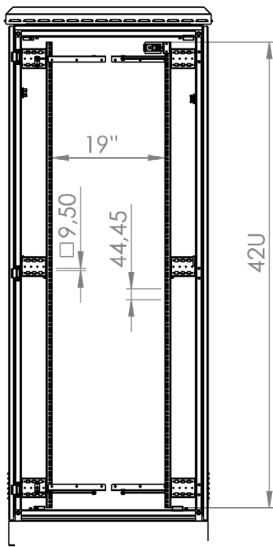

Front/inside view

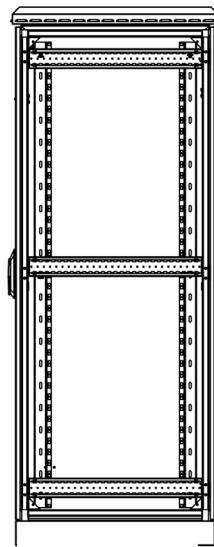

Side/inside view

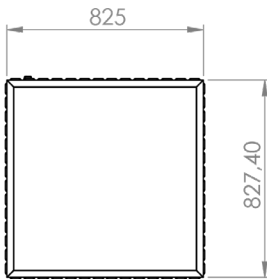

Top view

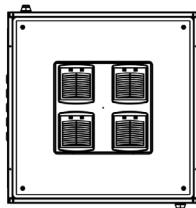

Top view

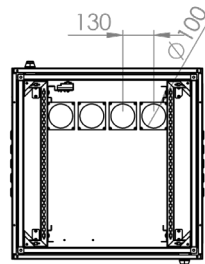

Top/inside view

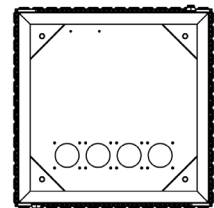

Bottom view

IP55 Outdoor Cabinets

IP55 Outdoor Cabinets Accessories

Please contact our sales office for all kinds of accessories (plinth, fan, shelf, cable management, pdu etc.)

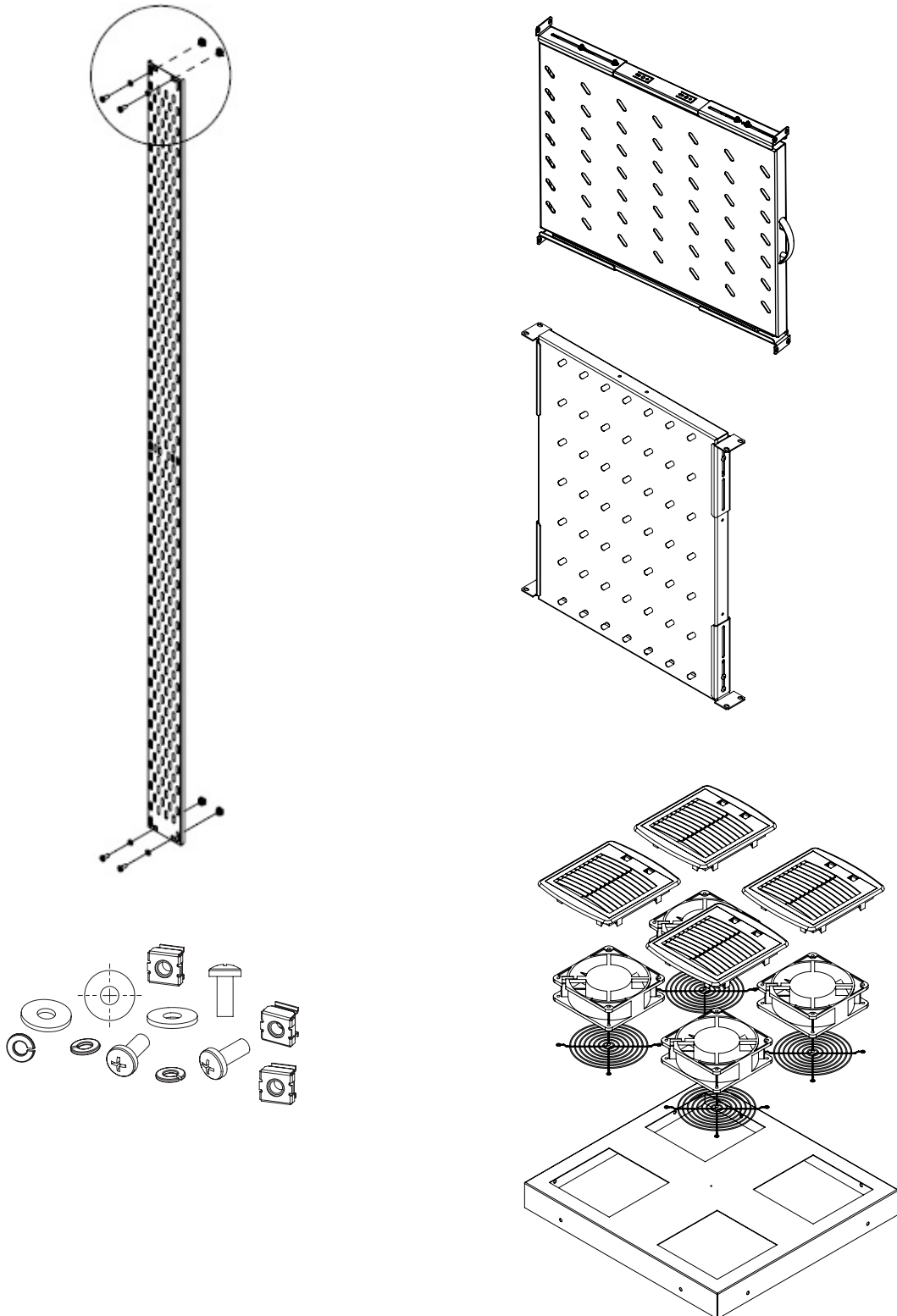

TESTS AND COMPLIED STANDARDS

TESTS AND COMPLIED STANDARDS

- 1) ISO 9001:2015 Quality Management System
- 2) ISO 14001:2015 Environmental Management System
- 3) ISO 27001:2013 Information Security Management System
- 4) ISO 45001:2018 Occupational Health and Safety Management System
- 5) 19" device mounting uprights IEC 297-1
- 6) EN 61587-1 Mechanical structures for electronic equipment.
- 7) All cabinet sizes complies with IEC 297-2.

SAFETY

PROTECTION AGAINST EXTERNAL MECHANICAL IMPACTS;

MECHANICAL STRUCTURES (CABINETS FOR ELECTRONIC EQUIPMENT);

ENVIRONMENTAL TESTING COLD/DRY HEAT/DAMP HEAT

HAVE BEEN TESTED ACCORDING TO THE STANDARD " EN 61587-1" WITH THE NORMATIVE STANDARDS: EN 60950, IEC 62262, EN 61587-1: 2012,

IEC 60068-2-1;IEC 60068-2-2;IEC 60068-2-30 contained within and certified by the approved institutions:

TSE CERTIFICATE NO

003788-TSE-08/02

TRANSPORT

ETS 300 019-1-2 Class 2.3

STORAGE

ETS 300 019-1-1 Class 1.2

Mobese Cabinet

Intro

Etap external type cabinets specially developed for Mobese systems meet the needs of the project offers custom-oriented solutions with developed robust and durable special profile technology.



GENERAL CHARACTERISTICS

- Compact sizes 7U, 300X300 mm and 12U 600X450 mm (Width x Depth)
- Optional 19" mounting rail for 12U 600X450 mm cabinet
- Natural ventilation system
- High performance temperature control
- Double-walled thermal insulation
- Standard colors, RAL 7035 Light Grey
- Solid and durable structure
- Anti-vandalism design
- IP66 protection level
- High level of protection against corrosion
- Fixed shelf, wall and pole hanger bracket
- Fan module is available
- Cable entries with glands
- Hinged top cover module





Extra Safety and Sturdy Structure

Effective protection level under severe weather conditions.

GENERAL CHARACTERISTICS

- Maximum protection for environmental and mechanical impacts, vandalism, electromagnetic emissions and extreme thermal conditions
- Premium materials are providing necessary tightness and protection against contact, foreign agents and water in accordance with the standard EN 61587-1 / 6.4 IEC 60529
- Robust and solid profile technology, high performance thermal control, a natural ventilation system
- Polyurethane gasket providing IP66 degree of protection for all outdoor surfaces
- Light Grey epoxy polyester electrostatic powder painting, fire retardant
- Maintains equipment at its optimum operating temperature



Mobese Cabinet

REFERENCE TABLE

7U 300x300 (MM)

PRODUCT REFERENCE	DESCRIPTION	HxWxD (mm)
GRLD707M02L00M59	7U 300x300 mm. IP66 outdoor mobese cabinet RAL7035	430x300x300

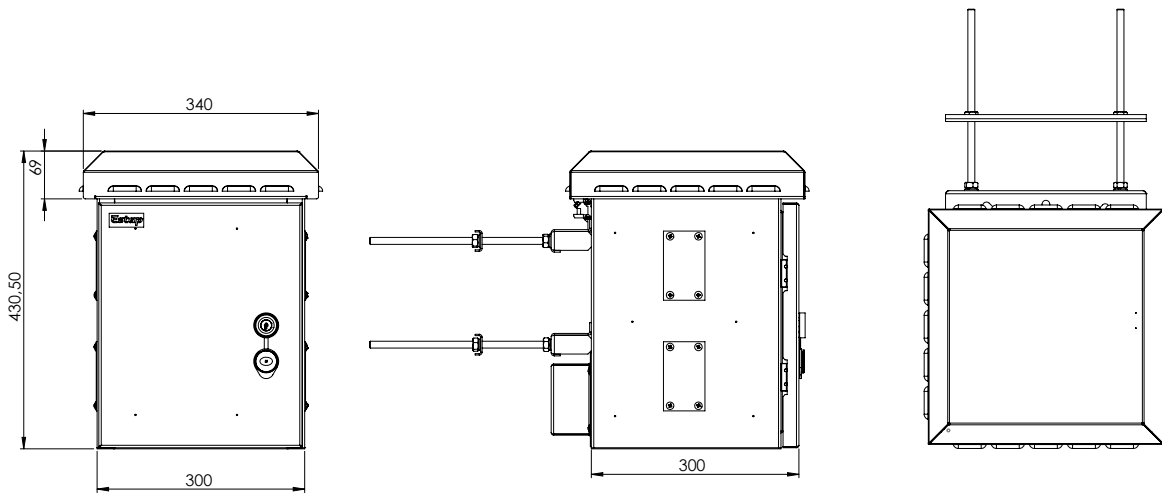

12U 600x450 (MM)

PRODUCT REFERENCE	DESCRIPTION	HxWxD (mm)
GRLD707M02L00M59	12U 600x450 mm. IP66 outdoor mobese cabinet RAL7035	650x600x450

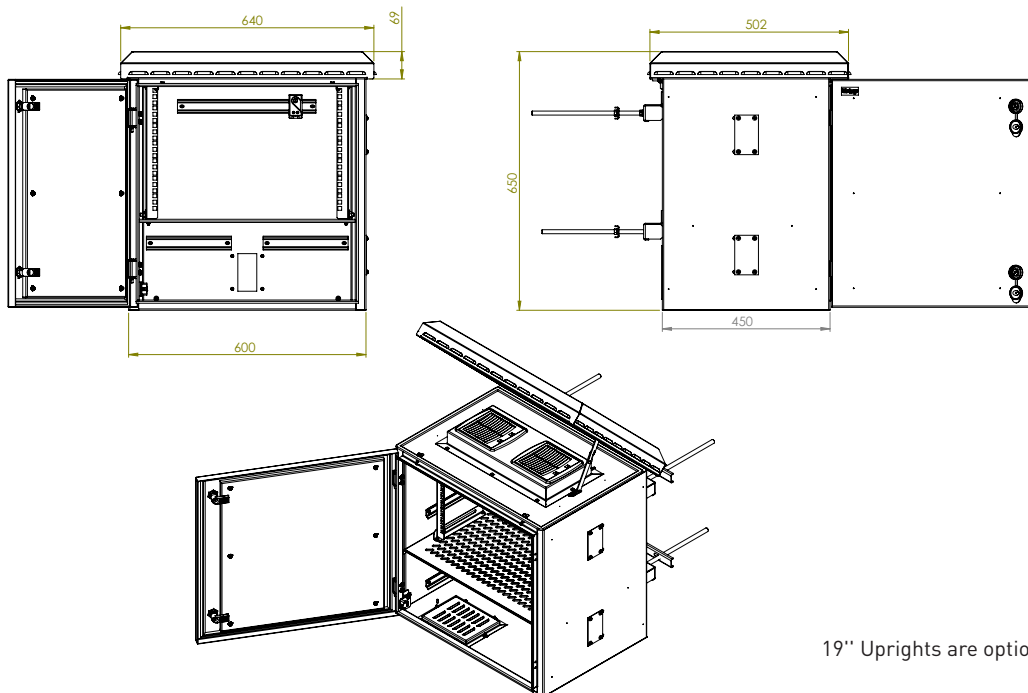

19" Uprights are optional

TESTS AND COMPLIED STANDARDS

TESTS AND COMPLIED STANDARDS

- 1) ISO 9001:2015 Quality Management System
- 2) ISO 14001:2015 Environmental Management System
- 3) ISO 27001:2013 Information Security Management System
- 4) ISO 45001:2018 Occupational Health and Safety Management System
- 5) 19" device mounting uprights IEC 297-1
- 6) EN 61587-1 Mechanical structures for electronic equipment.
- 7) All cabinet sizes complies with IEC 297-2.

SAFETY

PROTECTION AGAINST EXTERNAL MECHANICAL IMPACTS;

MECHANICAL STRUCTURES (CABINETS FOR ELECTRONIC EQUIPMENT);

ENVIRONMENTAL TESTING COLD/DRY HEAT/DAMP HEAT

HAVE BEEN TESTED ACCORDING TO THE STANDARD " EN 61587-1" WITH THE NORMATIVE STANDARDS: EN 60950, IEC 62262, EN 61587-1: 2012,

IEC 60068-2-1;IEC 60068-2-2;IEC 60068-2-30 contained within and certified by the approved institutions:

TSE CERTIFICATE NO

003788-TSE-08/02

TRANSPORT

ETS 300 019-1-2 Class 2.3

STORAGE

ETS 300 019-1-1 Class 1.2

Vertical and 19" Basic PDUs

Intro

Basic PDU's are units that provide power distribution in all systems where electricity connection is required such as data centers, server rooms, network cabinets. Estap basic pdu feeds your devices completely with their special designs.



GENERAL CHARACTERISTICS

- On-demand production
- Compliant with relevant standards
- On/off switch and circuit breaker options
- Suitable for mounting 19" and vertical mounting in the cabinet
- Easy to install with mounting accessories
- Schuko, C13-C19 and UK socket types are available
- Energy-efficiency
- Cost-effective
- Horizontal and vertical design
- Aluminium profile frame

REFERENCE TABLE

PRODUCT REFERENCE	PRODUCT DESCRIPTION
M443AL	3xDIN49440 Socket Schuko PDU, 19" 1U, aluminium profile frame, 1x16A MCB, 4000 Watt, 250V AC, 3x1.5mm ² , 3m cord with DIN 49441 plug, CE
M446AL	6xDIN49440 Socket Schuko PDU, 19" 1U, aluminium profile frame, 1x16A MCB, 4000 Watt, 250V AC, 3x1.5mm ² , 3m cord with DIN 49441 plug, CE
M446AL_UK	6xDIN49440 UK Socket Schuko PDU, 19" 1U, aluminium profile frame, 1x16A MCB, 4000 Watt, 250V AC, 3x1.5mm ² , 3m cord with 13A BS1363 plug, CE
M446ALD	6xDIN49440 Socket Schuko PDU, -double circuit (3+3) 19" with aluminium profile frame, 2x16A MCB, 4000 Watt, 250V AC, 3x1.5mm ² , 2, 5m cord with DIN 4944, CE
M446ALIEC	6xIEC 320 C13 Socket PDU, 19" aluminium profile frame, 1x16A MCB, 4000 Watt, 250V AC, IEC 320 C14 plug, CE
M446ALDIEC	6xIEC 320 C13 Socket PDU, double circuit (3+3), 19" 1U aluminium profile frame, 1x16A MCB, 4000 Watt, 250V AC, IEC 320 C14 plug, CE
M449ALC	9xDIN49440 Socket Schuko PDU, 19" 2U, aluminium profile frame, 1x16A MCB, 4000 Watt, 250V AC, 3x1.5mm ² , 3m cord - DIN49441 plug, CE
M449ALCD	9xDIN49440 Socket Schuko PDU, double circuit (4+5) 19" aluminium profile frame, 2x16A MCB, 4000 Watt, 250V AC, 3x1.5mm ² , 2, 5m cord with DIN 49441 plug, CE
M449ALCIEC	9xIEC 320 C13 Socket PDU, 19" aluminium profile frame, 1x16A MCB, 4000 Watt, 250V AC, IEC 320 C14 plug, CE
M449ALCDIEC	9xIEC 320 C13 Socket PDU, double circuit (4+5) 19" aluminium profile frame, 1x16A MCB, 4000 Watt, 250V AC, IEC 320 C14 plug, CE
M4411ALUK309	11xBS1363 UK Socket PDU, 19" 1U, aluminium profile frame, 20A MCB, 5000 Watt, 250V AC, 3x2.5mm ² , 3m cord - 32A IEC309 plug, CE
M4412ALC	12xDIN49440 Socket Schuko PDU, 19" 2U, aluminium profile frame, 1x16A MCB, 4000 Watt, 250V AC, 3x1.5mm ² , 3m cord - DIN49441 plug, CE
M4412AL_UK	12xDIN49440 UK Socket Schuko PDU, 19" 2U, aluminium profile frame, 1x16A MCB, 4000 Watt, 250V AC, 3x1.5mm ² , 3m cord - DIN49441 13A BS1363 plug, CE
M441226ALD	12xDIN49440 Socket Schuko PDU, double circuit (6+6), 2x16A MCB, 250V AC, compatible with 26U rack mounting, without cord, CE
M441836ALD	18xDIN49440 Socket Schuko PDU, double circuit (9+9) ZeroU, aluminium profile frame, 2x16A MCB, 250V AC, compatible with 36U rack mounting, without cord, CE
M441842ALD	18xDIN49440 Socket Schuko PDU, double circuit (9+9) ZeroU, aluminium profile frame, 2x16A MCB, 250V AC, compatible with 42U rack mounting, without cord, CE
M441847ALD	18xDIN49440 Socket Schuko PDU, double circuit (9+9) ZeroU, aluminium profile frame, 2x16A MCB, 250V AC, compatible with 47U rack mounting, without cord, CE
M441836ALDIEC	18xIEC 320 C13 Socket PDU, double circuit (9+9) ZeroU, aluminium profile frame, 2x16A MCB, 250V AC, compatible with 36U rack mounting, without cord, CE
M441842ALDIEC	18xIEC 320 C13 Socket PDU, double circuit (9+9) ZeroU, aluminium profile frame, 2x16A MCB, 250V AC, compatible with 42U rack mounting, without cord, CE
M441847ALDIEC	18xIEC 320 C13 Socket PDU, double circuit (9+9) ZeroU, aluminium profile frame, 2x16A MCB, 250V AC, compatible with 47U rack mounting, without cord, CE
M442442ALD	24xDIN49440 Socket Schuko PDU, double circuit (12+12), 2x16A MCB, 250V AC, compatible with 42U rack mounting, without cord, CE
M442442ALDIEC	24xIEC 320 C13 Socket PDU, double circuit (12+12), 2x16A MCB, 250V AC, compatible with 42U rack mounting, without cord, CE
M4424ALIECAMPMB	24xIEC 320 (20xC13 + 4xC19) Socket PDU with Ampermeter, ZeroU, alu profile frame, 2x16A MCB, 8000W, 250V AC, 3x6.0mm ² , 3m cord with IEC60309 plug (32A 2P+E), CE
M443042ALTIECMCB_SP	30xIEC 320 (24xC13 + 6xC19) Socket PDU with Ampermeter, ZeroU, alu profile frame, 3 Phase, 3x32A MCB, 24000W, 250V AC, 5x6.0mm ² , 3m cord with IEC60309 plug (32A 2P+E), CE

19" Basic PDU

19" TECHNICAL DRAWINGS

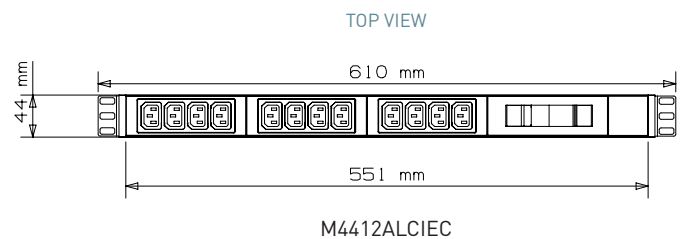
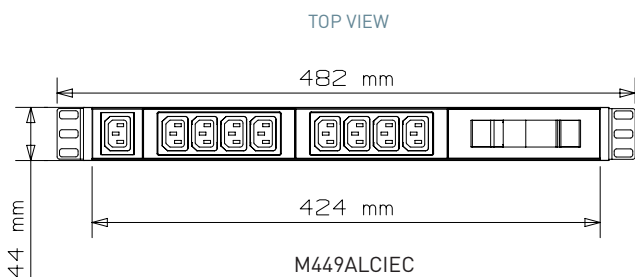
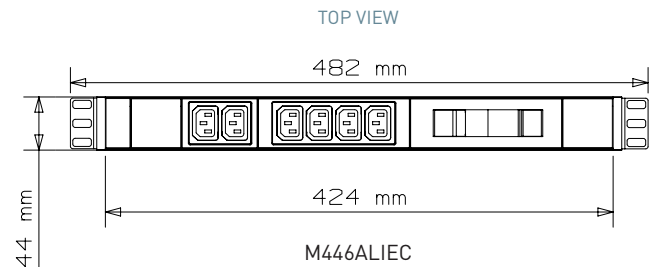
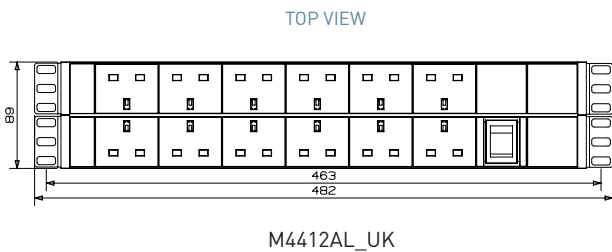
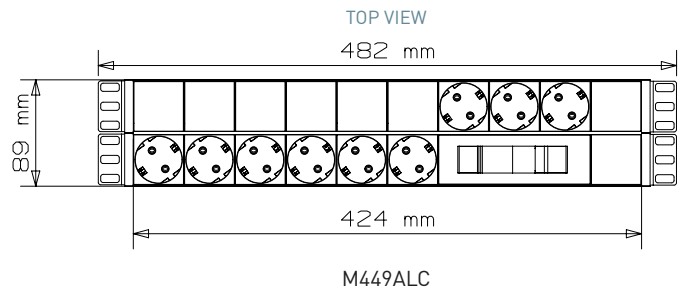
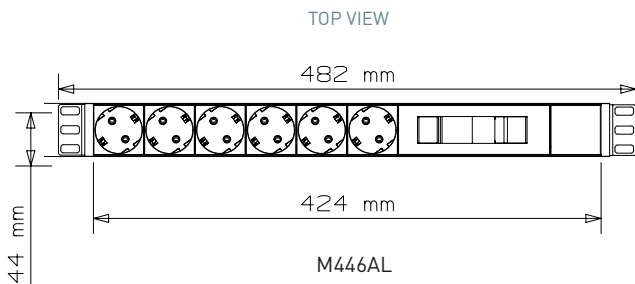
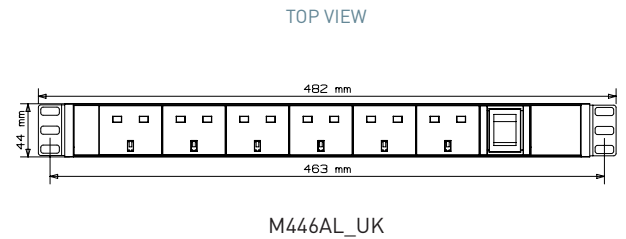
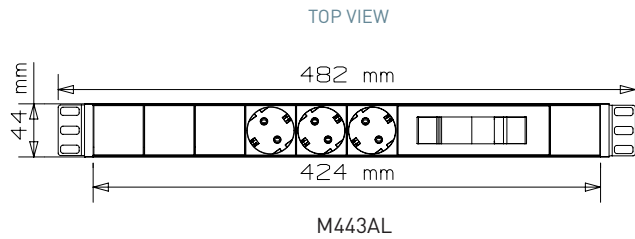

Vertical Basic PDU

VERTICAL PDU TECHNICAL DRAWINGS

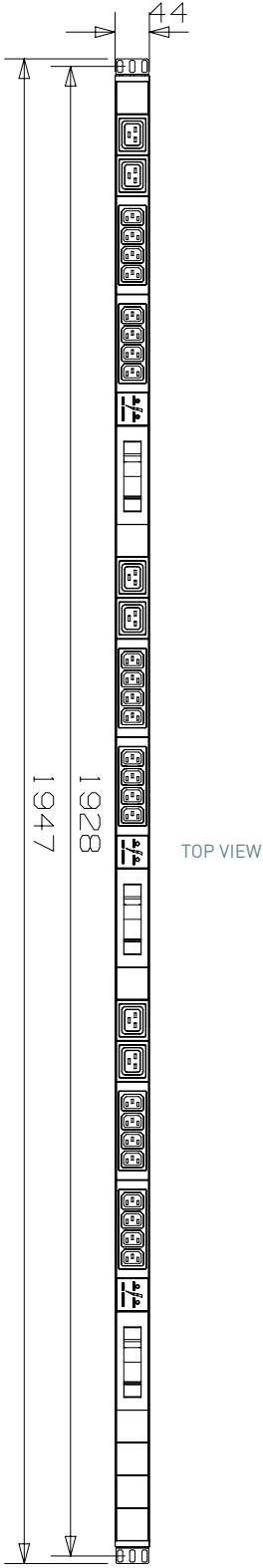

M443042ALTIECMCB_SP_ES

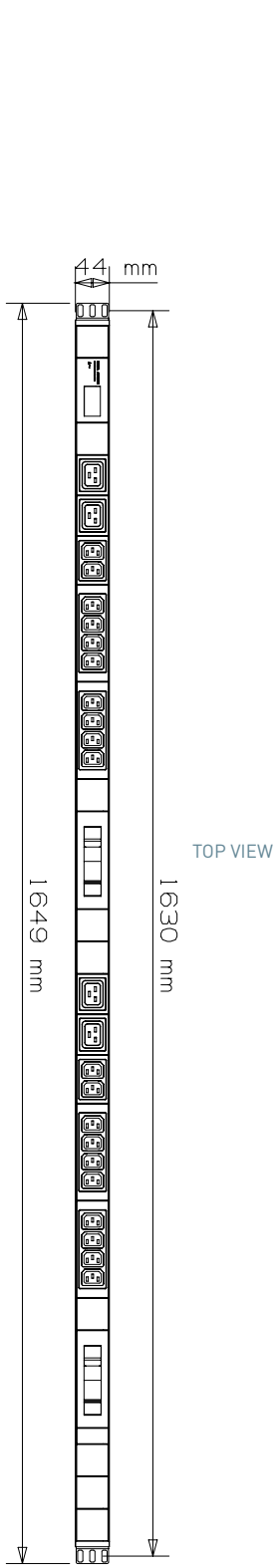

M4424ALIECAMPMCB

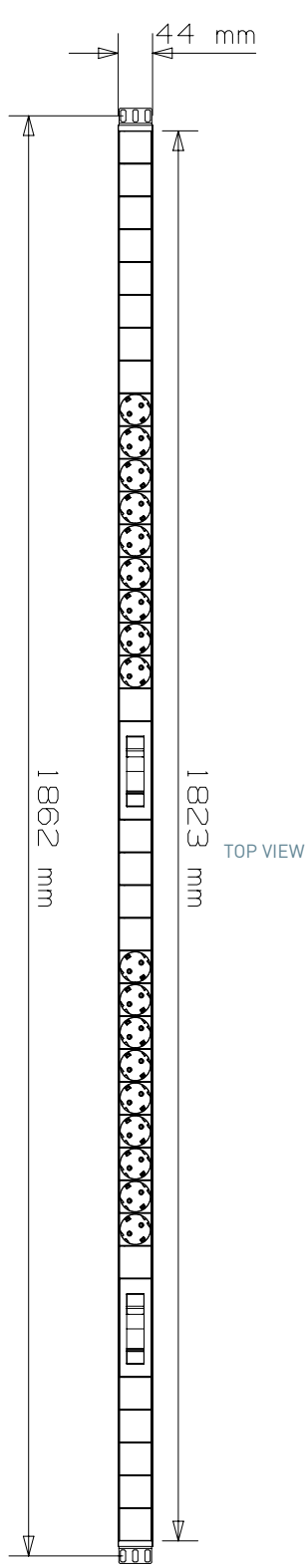

M441842ALD

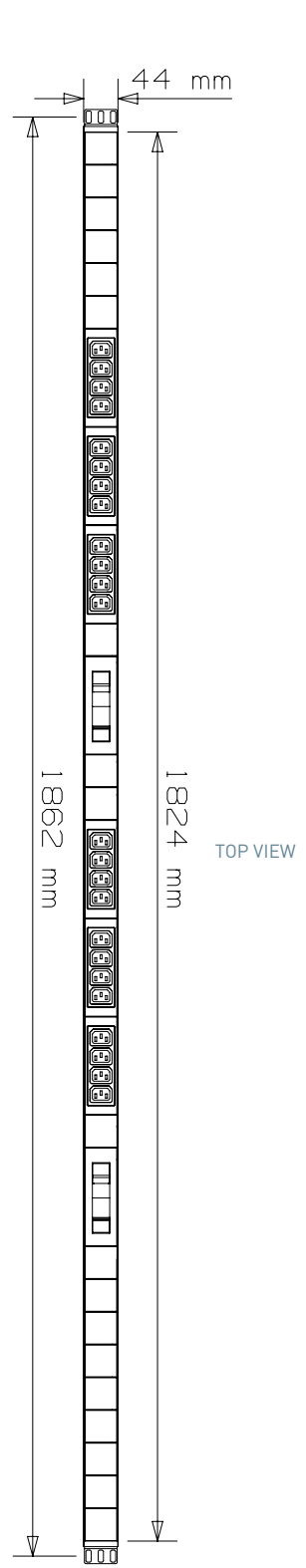

M442442ALDIEC

19" Basic PDU

19" TECHNICAL DRAWINGS

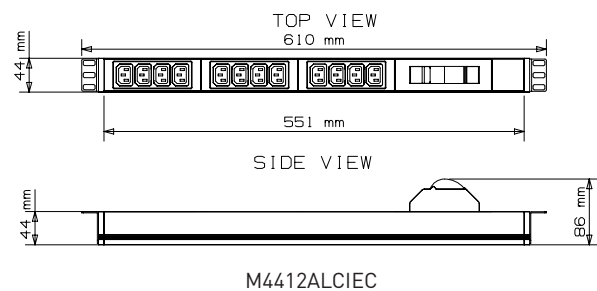
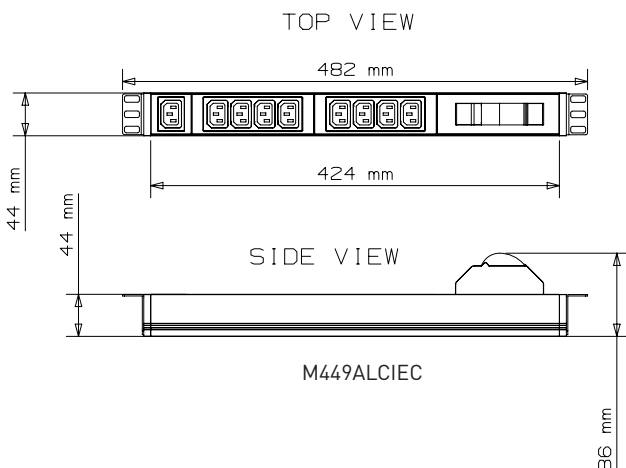
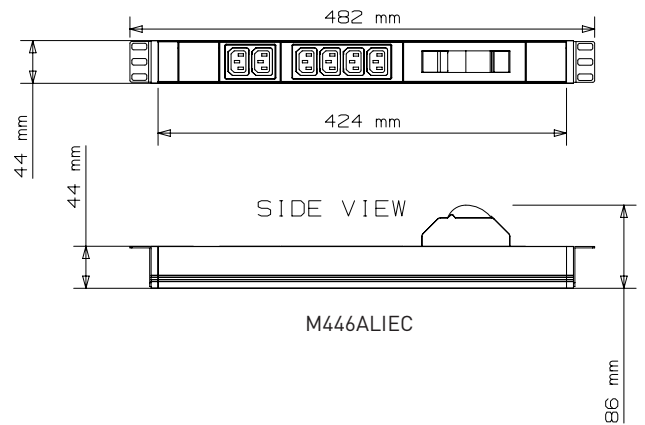
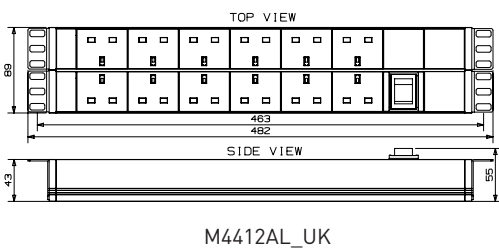
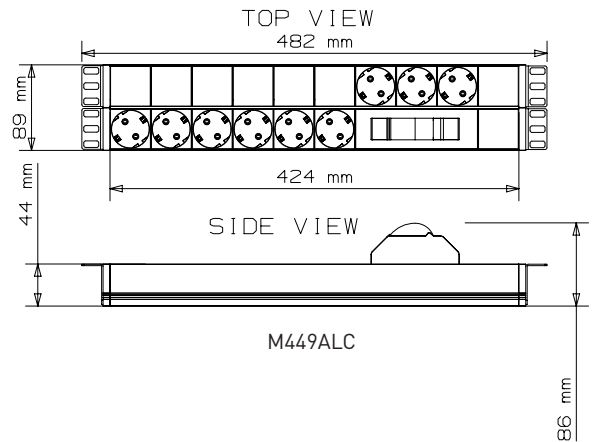
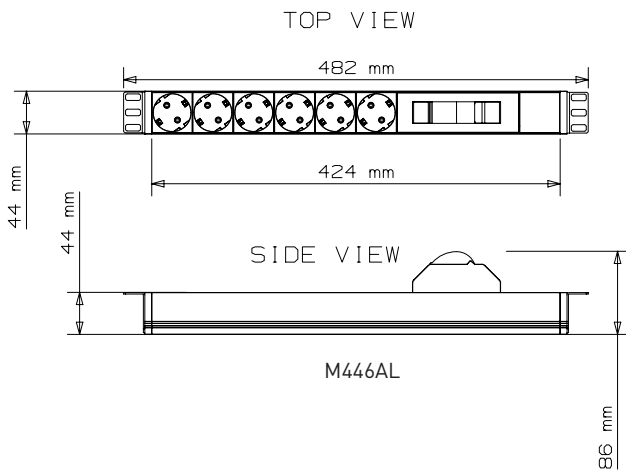
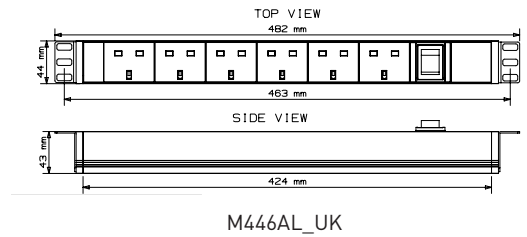
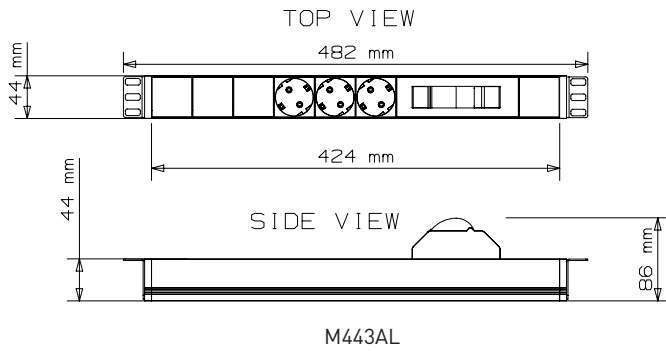

Headquarter

Esenehir Mah. Hale Sk. No: 6/1
Ümraniye - İSTANBUL - TURKEY
Tel: +90 216 622 30 00 - Fax: +90 216 621 92 35

Factory

Pelitli Mah. 4440 Sokak No: 12
Gebze - KOCAELİ - TURKEY
Tel. +90 262 751 16 00 - Fax. +90 262 751 16 02

 facebook.com/EstapTurkiye

 linkedin.com/company/estap-turkiye